

TrueVIS SG3-540/SG3-300

User's Manual

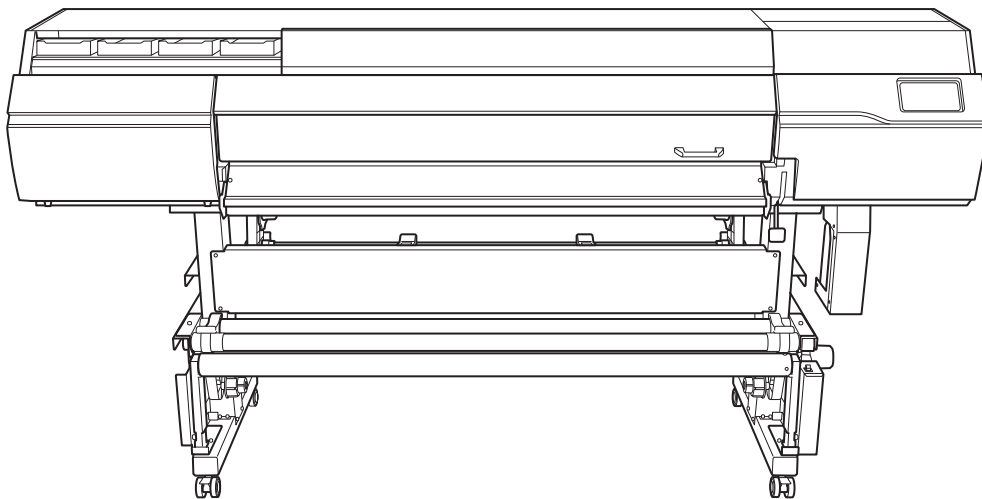

Thank you very much for purchasing this product.

- To ensure correct and safe usage with a full understanding of this product's performance, please be sure to read through this manual completely.
- Unauthorized copying or transferal, in whole or in part, of this manual is prohibited.
- The specifications of this product and the contents of this operation manual are subject to change without notice.
- The operation manual and the product have been prepared and tested as much as possible. If you find any misprints or errors, please inform us.
- Roland DG Corporation assumes no responsibility for any direct or indirect loss or damage that may occur through use of this product, regardless of any failure to perform on the part of this product.
- Roland DG Corporation assumes no responsibility for any direct or indirect loss or damage that may occur with respect to any article made using this product.

FA04213
R6-240131

<https://www.rolanddg.com/>
Copyright © 2022-2024 Roland DG Corporation

Contents

Basic Handling Methods	7
Basic Information	8
Part Names and Functions	9
Printer Unit	9
Take-up Unit	14
Operation Panel	15
About the Media Used	21
Types of Media	21
Conditions for Usable Media	22
Take-up Unit	23
Take-up Unit Use Conditions	23
About the Paper Tube	23
Basic Operations	24
Power Supply Operations	25
Turning the Power On	25
Turning the Power Off	26
Precautions When Operating the Power Supply	28
Sleep Mode (Power-saving Feature)	29
Setup of New Media	30
Setup of Roll Media	30
Setup of Sheet Media	53
Setup of Registered Media	67
Setup of Roll Media	67
Setup of Sheet Media	88
Checking before Output	100
LAN (Local Area Network) Settings	100
Preventing Sedimentation in Inks	101
Pausing and Canceling Output	102
Pausing and Resuming Output	102
Canceling Output	103
Separating the Media	104
Removing Media from the Take-up Unit	106
Ink Pouch Replacement	108
Out-of-ink Warnings	108
Ink Pouch Replacement	109
Cleaning Liquid Pouch Replacement	112
Out-of-cleaning-liquid Warnings	112
Cleaning Liquid Pouch Replacement	113
Output Method	115
Printing Method	116
Preparations for Printing Output	117
Step 1: Performing a Nozzle Drop-out Test	117
Step 2: Normal Cleaning Method	118
Starting Output	119
Cutting Method	121
Preparations for Cutting Output	122
Step 1: Switching Off the Print Heater and Dryer	122
Step 2: Preventing Pulling of the Media with Undue Force	123
Step 3: Adjusting Cutting	124
Starting Output	125

Printing and Cutting Method.....	126
Preparations for Printing and Cutting Output	127
Step 1: Performing a Nozzle Drop-out Test	127
Step 2: Normal Cleaning Method	128
Step 3: Adjusting Cutting.....	129
Step 4: Correcting the Misalignment of Printing and Cutting.....	130
Starting Output.....	132
How to Cut with Crop Marks.....	134
Preparations for Output with Crop Marks	135
Step 1: Performing a Nozzle Drop-out Test	135
Step 2: Normal Cleaning Method	136
Step 3: Adjusting Cutting.....	137
Step 4: Correct the misalignment of printing and cutting with crop marks at the same time.	138
Starting Output with Crop Marks	140
Preparations for Cutting Output.....	142
Step 1: Loading Media with Crop Marks	142
Step 2: Switching Off the Print Heater and Dryer	143
Step 3: Preventing Pulling of the Media with Undue Force	144
Starting Cutting Output.....	145
Optimizing Quality and Efficiency	146
Optimizing the Output Quality	147
Using the Correction Functions.....	148
Automatically Making Required Adjustments	148
Manual Adjustment: Reducing Horizontal Bands (Feed Correction Function).....	149
Manual Adjustment: Adjusting the Misalignment of the Ink Landing Position (Media Gap Adjustment)	151
Configuring Settings to Match the Properties of the Media	153
Changing the Print Head Height.....	153
Using Hard-to-Dry Media	155
Using Media That Wrinkles Easily/Does Not Move Smoothly	156
Using Sticky Media.....	157
Setting the Take-up Unit.....	158
Preventing Ink Discharge Issues.....	160
Preventing Soiling of the Media, Dot Drop-out, and Dot Displacement	160
Preventing Misaligned Media	161
Use Middle Pinch Rollers When Pulling Back or Feeding Media.....	161
Adjusting the Ink-drying Method	162
What Is the Media Heating System?.....	162
Changing the Print Heater Temperature	164
Changing the Dryer Temperature	166
Hints and Tips for Temperature Control	168
Setting the Temperature during Standby	169
Drying the Trailing Edge of the Printing Area on the Dryer	170
Switching Off the Print Heater and Dryer Together	171
Accurately Adjusting the Cutting Settings	173
Fine-tuning the Cutting Conditions	173
Accurately Adjusting the Cutting-in Amount.....	175
Performing Distance Correction during Cutting.....	177
Cutting to Make It Possible to Cut Corners Attractively (Over Cut)	178
Prioritizing the Cutting Settings of This Machine over the Software RIP Settings	180
Accurately Adjusting the Settings for Printing and Cutting	181
Correcting the Misalignment of Printing and Cutting	181
Correcting the Misalignment of the Printing and Cutting Positions during Cutting.....	184
Accurately Adjusting the Settings for Cutting with Crop Marks	186
Correcting the Misalignment of Printing and Cutting with Crop Marks (Concurrent Test for Printing and Cutting with Crop Marks)	186

Correcting the Misalignment of Printing and Cutting with Crop Marks (Separate Test for Printing/ Cutting with Crop Marks)	189
Correcting the Reading Sensor	193
Optimizing Work Efficiency	194
Managing the Media Settings	195
Changing the Media Settings	195
Checking the Registered Media Settings	197
Changing the Media Name	199
Duplicating Media Settings	200
Deleting Media Settings	201
Adjusting the Output-start Location	202
Setting the Base Point	202
Reducing Output Time	204
Speeding Up Output for Narrow Media	204
Other Useful Functions	205
Using the Print Light (Interior Light)	205
Performing Printing Tests Arranged Horizontally	206
Optimizing Operation Management	207
Managing the Operations Appropriately and Efficiently	208
Setting the Current Date/Time and Using It for Maintenance	208
Checking the Remaining Media	209
Showing/Hiding Notifications	211
Setting the Activation Interval for Sleep Mode (Power-saving Feature)	212
Managing the Basic Settings of the Printer	213
Changing the Display Language	213
Changing the Units of Measurement	214
Viewing Printer Information	215
Viewing Network Information	216
Adjusting the Brightness of the Operation Panel	217
Turning Off Operation Panel Sounds	218
Returning All Settings to Factory Defaults	219
Maintenance	220
Introduction	221
Important Notes on Handling and Use	222
Printer	222
Ink Pouches	222
Basic Maintenance Knowledge	223
Types and Timing of Maintenance	223
Measures When the Printer Is Not in Use for a Prolonged Period	225
Regular Maintenance	226
Print Head Check before Printing	227
Performing a Nozzle Drop-out Test	227
Cleaning the Machine	228
Cleaning the Media Path	228
Cleaning the Knife Carriage Roller	229
Cleaning around the Print Heads	230
Manual Cleaning Method	231
Consumable Products and Parts Related to Manual Cleaning	237
Disposing of Discharged Fluid	238
Precautions for Disposing of Discharged Fluid	239
If the Discharged Fluid Disposal Message Appears	240

Advanced Maintenance	242
When Dot Drop-out or Dot Displacement Occurs	243
Normal Cleaning Method	243
When Normal Cleaning Is Not Effective	244
Medium Cleaning Method.....	244
Powerful Cleaning Method	245
If Colors Are Uneven	246
Mixing the Ink by Shaking the Pouch Tray.....	246
Handling Severe Dot Drop-out and Dot Displacement.....	247
Ink Renewal Method.....	247
Partially Restricting the Print Heads Used for Printing	251
Emergency Measure) Cleaning the Print Head Surface	253
When the Operation Panel Is Dirty	254
Operation Panel Cleaning Method	254
Replacing Consumable Parts.....	255
Replacing Parts for Maintenance	256
Replacing the Wiper and the Tray Pad	256
Cleaning the Wiper Tray.....	259
Replacing the Blade/Separating Knife.....	262
Replacing the Blade	262
Replacing the Separating Knife.....	269

Troubleshooting Methods.....272

Output Quality Problems.....	273
Printed results are coarse or contain horizontal stripes.....	274
Do the print heads cause dot drop-out?.....	274
Is the print head height appropriate?	274
Have you carried out [Feed Correction]?	274
Have you carried out [Media Gap Adjustment] (ink landing position correction)?	274
Is the printer installed in a level and stable location?.....	275
Is the media heating system at a suitable temperature?.....	275
Is the temperature of the room too low?	275
Is the print mode suitable?.....	275
Is the media loaded correctly?	275
Are the [Media Settings] appropriate?.....	275
The media becomes soiled when printed	276
Do the print heads come into contact with the media?	276
Are the print heads dirty?	276
Are the pinch rollers or the media clamps dirty?.....	276
Colors are unstable or uneven	277
Have you tried mixing the ink by shaking the pouch trays?.....	277
Are colors still uneven after mixing the ink by shaking the pouch trays?	277
Is the media wrinkled?.....	277
Was printing paused partway through?.....	277
Is the printer installed in a level and stable location?.....	277
Is the media loaded correctly?	277
Are the operating parameters set to appropriate values?	278
Are the [Media Settings] appropriate?.....	278
Cutting Is Misaligned, Skewed, or Not Clean	279
Is the media loaded correctly?	279
Are the settings for the cutting conditions appropriate?.....	279
Is the length of output too long?.....	279
Are you using media that exhibits large expansion and contraction?	279
Is the setting for the [Cutting Distance Correction] menu item (under [Cutting Settings]) correct?	279
Are the pinch rollers placed on the proper locations?.....	280
Have you corrected the misalignment of printing and cutting?	280

Is the blade holder installed appropriately?.....	280
Is the blade worn?	280
Is there any buildup of pieces of material or dust inside the blade holder?	280
Problems in Cutting with Crop Marks	282
Automatic Detection of Crop Marks Fails	283
Is the media wrinkled or warped?	283
Is the media size too large?	283
Are you using media that is likely to reflect light or has deep colors?.....	283
Are you using transparent media?	283
Printing and Cutting Are Misaligned.....	284
Have you corrected the misalignment of printing and cutting with crop marks?	284
Media Feed Problems	285
Media Wrinkles	286
Is the media loaded and set up straight and securely?	286
Was loaded media allowed to stand for some time?	286
Are the media clamps installed?	286
Was the media loaded while the print heater was hot?	286
Are the media heating system temperatures too high?.....	286
Is the temperature of the room too low?	286
Is the humidity of the room too high?.....	286
Is the media sagging?	287
Media Feeding Is Not Straight.....	288
Is the media loaded and set up straight and securely?	288
Media Feeding Is Not Smooth	289
Is some other object coming into contact with the media?	289
Is the media too thick?	289
Are the grit rollers dirty?.....	289
A Media Jam Occurs!	290
Is an error message displayed?	290
Is the media warped or wrinkled?	290
Is the height of the print heads too low?	290
Are the grit rollers dirty?.....	290
Are the media clamps installed?	290
Is the media loaded and set up straight and securely?	290
Is some other object coming into contact with the media?	291
Is the media too thick?	291
Machine Problems	292
The Print Heads Do Not Move	293
What to Do First	293
If the Print Heads Still Do Not Move	293
The printer unit does not run.....	295
Is the power switched on?.....	295
Is [Output possible.] displayed?	295
Are any covers open?	295
Is the message [Output is currently paused.] displayed on the screen?.....	295
Is a message displayed on the screen?	295
Are the cables connected?	295
Is the LAN routing appropriate?	296
Are the LAN settings correct?.....	296
Did the software RIP end abnormally?	296
Is an [Ink Pouch Tray Error] displayed?	296
The Media Heating System Doesn't Warm Up	298
Is the media loaded?	298
Is [Heater Power] turned on?	298
Is the temperature of the room too low?	298
Cannot Separate the Media	299

Is the separating knife installed?.....	299
Messages on the Operation Panel.....	300
Messages	301
[When output, cleaning, and other operations are completed, discard the discharged fluid.]	301
[The time for manual cleaning has arrived.].....	301
[The time for wiper replacement has arrived.]	301
[The time for wiper tray cleaning has arrived.].....	301
[Print head protection mode has activated.]	301
[Remaining cleaning liquid level low.]	302
[Replace the cleaning liquid pouch.]	302
[Install the cleaning liquid pouch.]	302
[The time for ink mixing has arrived.]	302
[Operation of the take-up unit stopped.].....	303
[Place the middle pinch rollers over all the grit rollers.]	303
[Install the media clamps correctly.]	303
[Media clamps could not be detected.]	303
[The LAN cable is not connected.].....	304
[Connection is requiring too much time. Manually setting the IP address will improve the connection speed.].....	304
[The media could not be detected automatically. Manually set the printing area.].....	304
Error Messages.....	306
[Ink Pouch Tray Error]	306
[Cover Open Error]	306
[Media End Error].....	306
[Pinch Lever Error].....	307
[Media Loading Error].....	307
[Drain Bottle Error]	307
[Crop Mark Detection Error].....	307
[Unable to Fill Wiper Cleaning Liquid]	308
[Pinch Roller Error]	308
[Print Head Height Mismatch].....	308
[Insufficient Media Width]	308
[Motor Error]	309
[Print Head Dry-out Error].....	309
[Low Temperature Error]	309
[High Temperature Error].....	310
[Pump Stop Error]	310
[Cleaning Error (Ink Pouch Tray)]	310
[Cleaning Error (Drain Bottle)].....	310
[Take-up Unit Communication Error].....	310
[Service Call]	310
[Software error]	311

Appendix..... 312

Operations When Moving the Unit	313
Preparing to Move the Machine	314
Step 1: Removing Media and the Blade Holder.....	314
Step 2: Discharging the Wiper Tray Cleaning Liquid.....	316
Step 3: Secure the print heads in place using the retainer.	317
Step 4: Reinstalling the Machine	318
Main Specifications	320
Printing/Cutting Area	321
Maximum Area	321
Maximum Printing Area When Using Crop Marks.....	322
Media Separation Location during Continuous Printing.....	323
About the Blade.....	324

Basic Handling Methods

Basic Information

Part Names and Functions.....	9
Printer Unit.....	9
Take-up Unit	14
Operation Panel	15
About the Media Used	21
Types of Media	21
Conditions for Usable Media.....	22
Take-up Unit.....	23
Take-up Unit Use Conditions.....	23
About the Paper Tube.....	23

Part Names and Functions

Printer Unit

Front

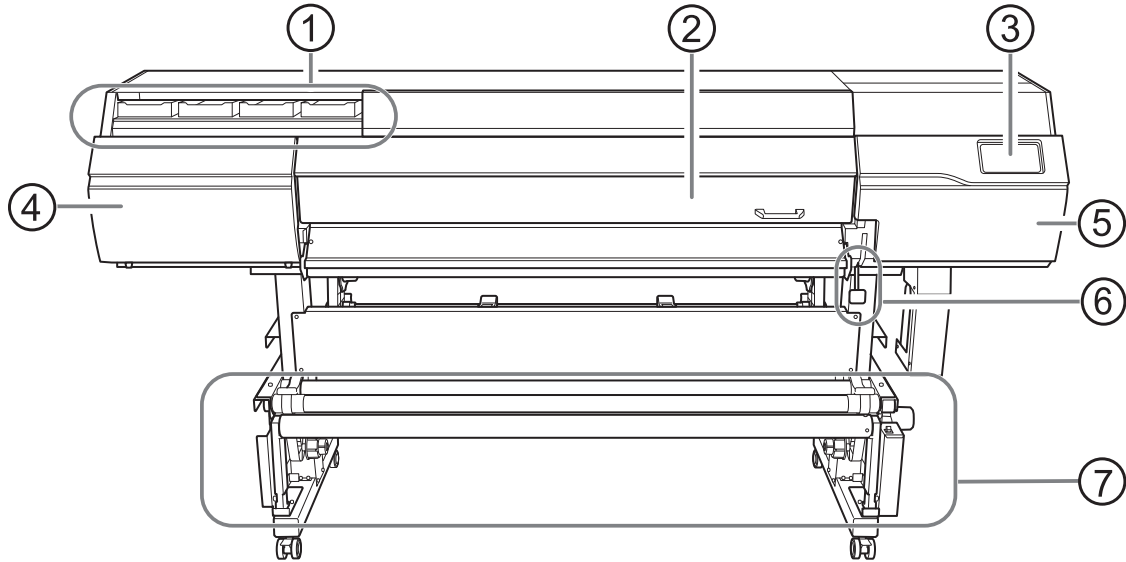

No.	Name	Function overview
①	Ink slots	The slots in which the pouch trays are inserted.
②	Front cover	Open this when necessary, such as when loading media. In all other situations, keep the front cover closed.
③	Operation panel	The panel used to operate the machine. P. 15 Operation Panel
④	Left cover	Open this when you perform maintenance.
⑤	Right cover	Open this when you perform maintenance.
⑥	Loading lever (front)	Operate this when you load media.
⑦	Take-up Unit	Takes up the media after printing.

Rear

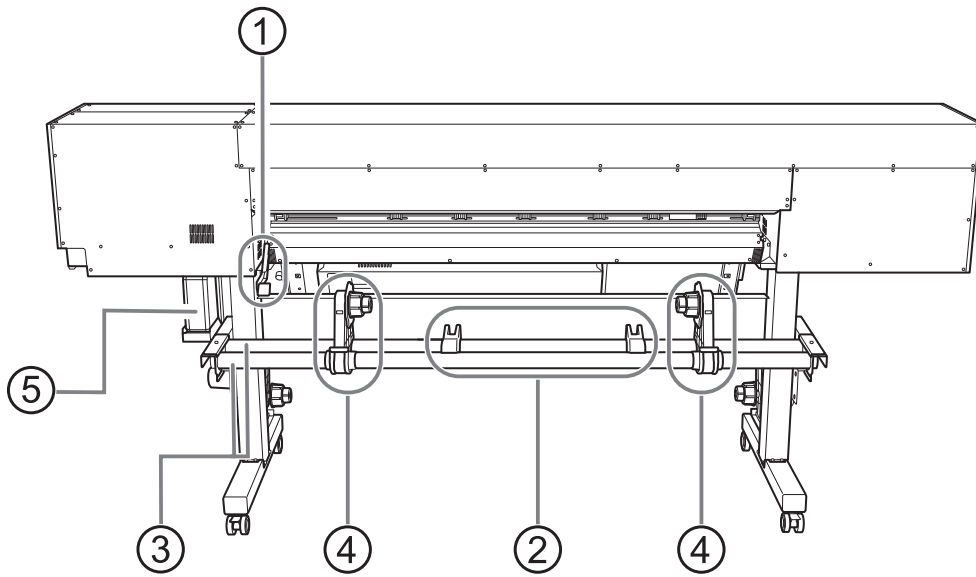

No.	Name	Function overview
①	Loading lever (rear)	Use these when you load media.
②	Media stays	
③	Shafts	
④	Media holders	
⑤	Drain bottle	Discharged fluid is stored in this bottle.

Side

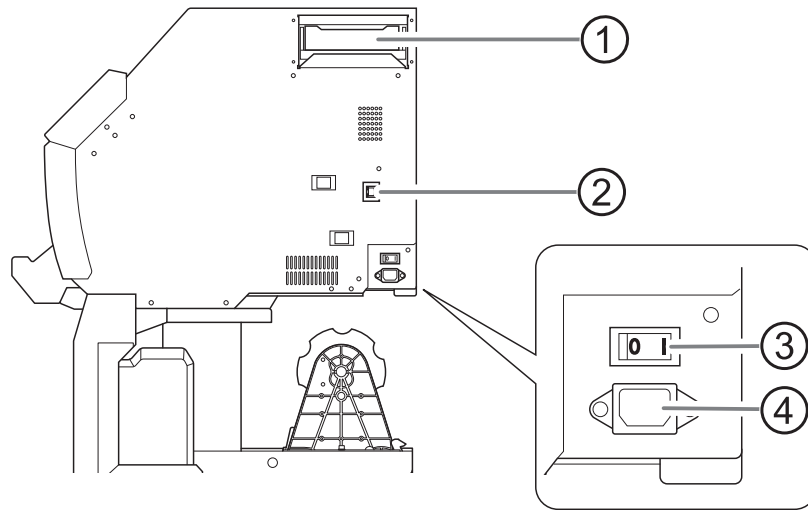

No.	Name	Function overview
①	Cleaning liquid slot	Insert the pouch tray with the cleaning liquid pouch into this slot.
②	Ethernet connector	Use this to connect an Ethernet cable.
③	Main power switch	Switch the main power on/off.
④	Power-cord connector	Use this to connect the power cable.

Front Cover Interior/Print Head Area

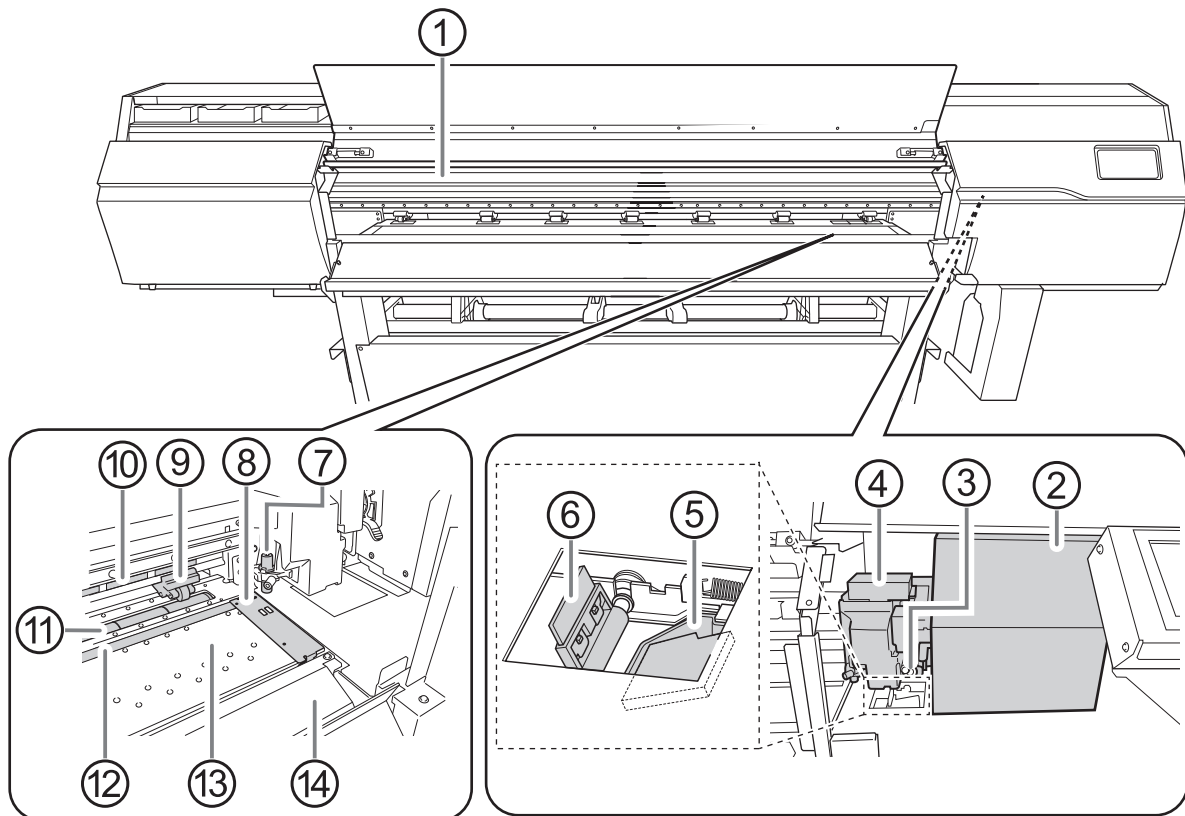

No.	Name	Function overview
①	Print light	This light illuminates the front cover interior. This makes it easier to see the printing status. It flashes if a serious error occurs.
②	Print-head carriage	The print heads are inside here.
③	Separating knife	The knife used to separate the media.
④	Cutting carriage	The blade and the separating knife are inside here.
⑤	Wiper tray	This houses the cleaning liquid used to clean the wiper. It contains a tray pad.
⑥	Wiper	Cleans the print heads during automatic cleaning and in similar situations.
⑦	Blade holder	This houses the blade used during cutting.
⑧	Media clamp	This clamps the edge of the media to keep it from coming loose. It also prevents fuzz on the cut edge of the media from touching the print heads.
⑨	Pinch roller (left pinch roller, right pinch roller, and middle pinch roller)	These clamp the media when the loading lever is lowered. These rollers are called the left pinch roller, the right pinch roller, and the middle pinch roller according to their positions.
⑩	Grit pattern	This indicates the location of a grit roller. When loading media, be sure to place the pinch rollers within the ranges indicated by these patterns.
⑪	Grit roller	This is one of these rollers that feed the media.
⑫	Blade protector	This is the path that the blade takes during cutting. It protects the tip of the blade.
⑬	Platen	This is the path over which the media passes. A suction fan that keeps the media from coming loose and a print heater that helps fix the ink are built in.

No.	Name	Function overview
⑭	Apron	This has a built-in dryer to speed up drying of the ink.

RELATED LINKS

- [P. 13 Serious Errors Indicated by the Print Light](#)

Serious Errors Indicated by the Print Light

If an error that may lead to serious damage to the printer occurs, the print light blinks.

This indicates one of the situations shown below.

When the print light blinks, the error also appears on the operation panel's display screen.

Display screen	Error overview
[Print Head Dry-out Error]	The print heads were about to dry out. The print heads may be damaged if allowed to dry out.
[Motor Error]	An excessive load was applied to the motor. If this error is not addressed, the print heads may be damaged.
[Low Temperature Error]	The ambient temperature in the printer's installation location has fallen below the temperature in which operation is possible. If this error is not addressed, the printer may malfunction.
[High Temperature Error]	The ambient temperature in the printer's installation location has risen above the temperature in which operation is possible. If this error is not addressed, the printer may malfunction.
[Pump Stop Error]	An excessive load was applied to the pump within the machine. If this error is not addressed, the pump may malfunction.
[Service Call]	An unrecoverable error or an error that requires a part replacement has occurred.

RELATED LINKS

- [P. 306 Error Messages](#)

If a Cover Opens during Operation

If the front cover, left cover, or right cover (hereinafter referred to as "cover") opens during an output operation or while setting up the media, the machine makes an emergency stop. When an emergency stop occurs, a message prompting you to close the cover appears on the screen. Close the covers as directed in the instructions shown on the screen.

When the cover is closed, you will be able to continue the operation.

If you cannot continue the operation even after you close the cover, a nonrecoverable error may have occurred.

RELATED LINKS

- [P. 306 Error Messages](#)

Take-up Unit

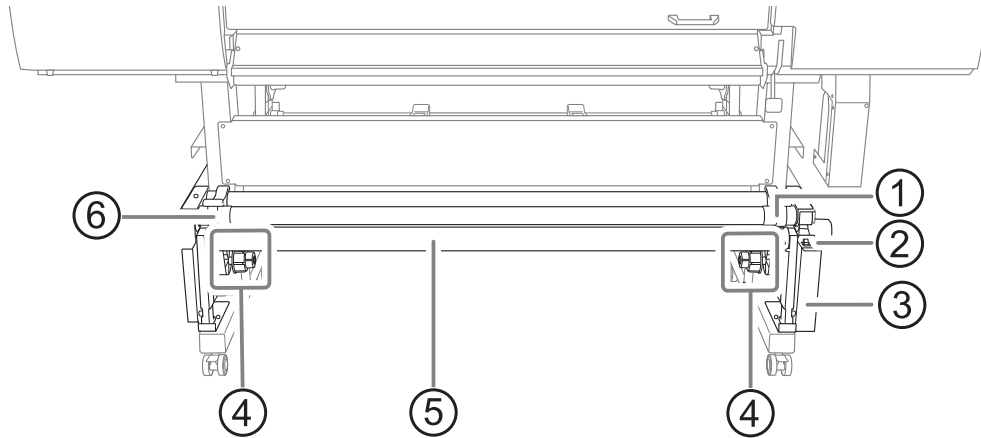

No.	Name	Function overview
①	Motorized media holder	This is used when loading the paper tube for take-up. A built-in motor rotates the tube.
②	MANUAL switch	Used when taking up media manually, not with the operation panel.
③	Control box	This controls the media take-up.
④	End caps	These are used when loading the paper tube for take-up.
⑤	Dancer roller	This keeps the media tension constant. Lower this roller to the rear when not using the take-up unit.
⑥	Left media holder	This is used when loading the paper tube for take-up.

Operation Panel

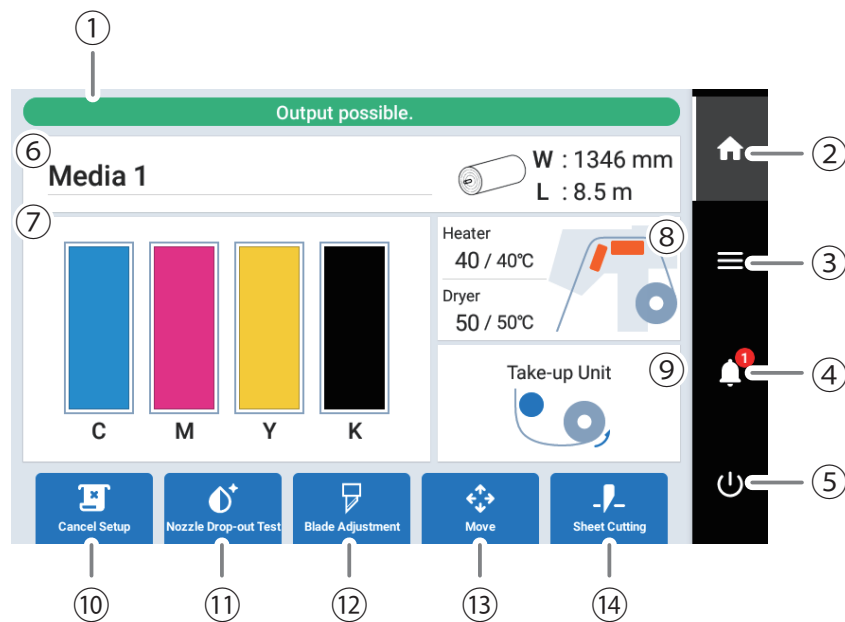

No.	Name	Details
①	Status bar	Displays the printer status and indicates the next operation.
②	Home	Displays the home screen.
③	Menu	Displays various setting menus.
④	Notifications	Displays important information. When there are notifications, their number is displayed next to the icon.
⑤	Sub power	Controls the power to the operation panel.
⑥	Media information	Displays the media name, media width (W), and remaining media (L). This information is only displayed when media has been set up and there is media remaining. Tap the media width (W) or the remaining media (L) to display the [Remaining Media Management] screen on which you can set the remaining media. P. 209 Checking the Remaining Media
⑦	Amount of ink remaining	Displays the amount of ink remaining for each ink type. If it is time to replace ink,  is displayed next to the corresponding type. Tap this icon to display the detailed information for the ink.
⑧	Heater Temperature	The print heater and dryer temperatures are displayed as current temperature/set temperature. Tap one of these items to display a screen for: <ul style="list-style-type: none"> • Turning [Heater Power] on/off. • Turning [Print Heater] on/off and setting its temperature. • Turning [Dryer] on/off and setting its temperature.
⑨	Take-up Unit	Displays the status of the take-up unit. Tap this icon to display the [Take-up] screen on which you can set the [Take-up Method] and [Take-up Direction] .
⑩	[Setup] / [Cancel Setup]	Starts/cancels the setting up of the media. P. 30 Setup of New Media P. 67 Setup of Registered Media
⑪	[Cleaning] / [Nozzle Drop-out Test]	Displays the menu related to the printing test and cleaning for the nozzle drop-out check.

Part Names and Functions

No.	Name	Details
⑫	[Blade Adjustment]	Sets cutting conditions. This is only enabled when media is loaded.
⑬	[Move]	Feeds the media and moves the carriage. You can also set the position moved to as the right edge of the output area (the base point). P. 202 Adjusting the Output-start Location
⑭	[Sheet Cutting]	Activates the separating knife to separate the media. You can also perforate the media to take it up and separate it at a later time.

Menu List

Tap  to display the list of operations.

MEMO

[Media Settings] only appears when media is loaded.

Level 1	Level 2	Level 3	Level 4	Details	
[Media Settings] ^{*1}	[List of Media Settings]			Lists the settings of the media that has been set up. Tap a setting to move to a screen for changing this setting.	
	[Printing Settings]	[Print Head Height]		Checks/changes the head height.	
		[Batch Automatic Correction]		Adjustments are performed in the following order: [Multi Sensor Adjustment], [Media Gap Adjustment], then [Feed Correction].	
		[Feed Correction]	[Simple Correction (Auto)]		Adjusts the media feed amount during printing. With [Simple Correction (Auto)], a test pattern is printed and then read with a sensor to automatically set the correction value.
			[Detailed Correction (Manual)]		Adjusts the media feed amount during printing. With [Detailed Correction (Manual)], a test pattern is printed, and then the correction value is entered manually after the printed correction value is checked visually.
		[Media Gap Adjustment]	[Simple Correction (Auto)]		Corrects the ink landing position. With [Simple Correction (Auto)], a test pattern is printed and then read with a sensor to automatically set the correction value.
			[Detailed Correction (Manual)]		Corrects the ink landing position. With [Detailed Correction (Manual)], a test pattern is printed, and then the correction value is entered manually after the printed correction value is checked visually.
	[Cutting Settings]	[Blade Adjustment]		Sets cutting conditions such as [Blade Force] and [Cutting Speed].	
		[Print & Cut Position Adjustment]		Corrects misalignment in the printing position and the cutting position during printing and cutting.	
		[Crop Cut Position Adjustment]		Corrects misalignment in the crop mark positions and the cutting position when cutting with crop marks.	
		[Cutting Distance Correction]		Corrects misalignment in the cutting line length due to changes in the media movement distance.	
		[Over Cut]		Cutting the corners of the border of the cutting line slightly longer makes it possible to cut the corners attractively.	

Part Names and Functions

Level 1	Level 2	Level 3	Level 4	Details
[Media Settings] ^{*1}	[Heater Settings]	[Heater Temperature]	[Heater Power]	Switches the print heater and dryer on/off as a batch. Switch these off in situations such as cutting that does not require the media heating system.
			[Print Heater]	Switches the print heater on/off and changes the set temperature.
			[Dryer]	Switches the dryer on/off and changes the set temperature.
		[Dry After Printing]	Switches on/off the function that moves the media to and dries the media with the dryer after printing and sets the drying time.	
	[Other Media Settings]	[Multi Sensor Adjustment]	Optimizes the status of the multi sensor used when reading crop marks and with the automatic correction function.	
		[Drying Time Per Scan]	Sets the drying time per scan operation of the carriage.	
		[Media Suction Force]	Adjusts the media suction force of the platen.	
		[Printing Movement Range]	Select the carriage movement range during printing from [Output Data Width], [Media Width], and [Full Width].	
		[Media Sticking Prevention]	When set to [Enable], the media is peeled off before printing.	
		[Middle Pinch Auto Raise/Lower]	Causes the middle pinch rollers to go up automatically during pullback printing or printing and cutting.	
		[Batch Media Settings]	The minimum settings required for media setup can be configured by following the on-screen instructions on the operation panel.	
[Media Management]		Displays a list of registered media. Up to 20 media names can be saved, and the following operations on media settings are possible. <ul style="list-style-type: none"> • Checking setting details in a list • Changing media names • Copying media settings • Deleting media settings 		
[Cleaning]	[Printing Test]	Before printing, use [Nozzle Drop-out Test] to check whether ink is discharged from the print heads correctly. If nozzle drop-out is present, perform cleaning appropriate for the severity of the drop-out. If faulty ink discharge cannot be improved, the problematic nozzle can be identified with [Nozzle Mask Test], making it possible to stop using this nozzle.		
	[Normal Cleaning]	If dot drop-out or dot displacement occurs, clean the print heads. If the problem cannot be fixed, perform more powerful cleaning.		
	[Medium Cleaning]			
	[Powerful Cleaning]			
	[Manual Cleaning]	Use cleaning liquid and a cleaning stick to clean the area around the print heads.		

Level 1	Level 2	Level 3	Level 4	Details
[Maintenance]	[Wiper Replacement]			Replaces the wiper and tray pad.
	[Blade Replacement]			Replaces the blade used in cutting.
	[Separating Knife Replacement]			Replaces the separating knife used in media separation.
	[Ink Renewal]			Perform this operation when ink discharge issues or uneven colors are not resolved even after [Normal Cleaning], [Medium Cleaning], [Powerful Cleaning], and [Manual Cleaning]. However, this operation consumes a large amount of ink and may damage the print heads, so do not perform it more than necessary.
	[Wiper Tray Cleaning]			Use this operation to clean the wiper tray.
	[Wiper Tray Discharging]			Use this operation to discharge the cleaning liquid from the wiper tray.
	[Drain Bottle]			A message appears when discharged fluid has collected in the drain bottle. Use this menu item to discard this fluid.
[Preferences]	[Media Edge Detection]			Sets whether to detect the leading and trailing edges of the media. When using transparent media, whose edges cannot be detected, the media can be set up without detecting the edges by selecting [Disable].
	[Print Light]			Select [On], [Off], or [Auto] for the print light. Select [Auto] to automatically turn the light on/off according to the status of the printer.
	[Take-up]			Sets the [Take-up Method] and [Take-up Direction] for the take-up unit.
	[Remaining Media Management]			Sets the amount of remaining media that has been set up and displays this amount. This amount can also be printed on the media.
	[Skewing Correction Support at Setup]			Provides support, preventing skewed installation of the media by making a sound and operating an automatic suction fan during setup.
	[Printing Test Position]			Sets the direction for test pattern printing: [Feed] or [Scan].
	[Perforated Sheet Cutting]			Sets the perforated sheet cutting conditions.
	[Cleaning during Printing]			Selects the frequency of cleaning during printing from [No Cleaning], [Every Page], [Periodically (Job Priority)], and [Periodically (Time Priority)]. After selecting [Periodically (Job Priority)] or [Periodically (Time Priority)], set the time from the previous cleaning to the next cleaning.
	[Standby Heater Temperature]			Sets the heater temperature when media has not been set up.
	[Prefeeding at Output]			Prefeeds the media when it is fed out, such as during cutting, preventing the pulling of the media with undue force.
	[Priority for Cutting Settings]			Sets whether to prioritize the cutting settings of the machine or the software RIP.
	[Notifications On/Off]			When [Enable] is selected, notifications are displayed at the appropriate times. <ul style="list-style-type: none"> • [Ink Mixing Notification] • [Middle Pinch Roller Placement Notification] • [Media Clamp Placement Notification]
	[Sleep Time]			Sets the time until sleep mode (the state in which the power-saving features operate) activates.
[Reset to Factory Defaults]			Returns all settings other than [Language] and [Units] to their factory default values.	

Part Names and Functions

Level 1	Level 2	Level 3	Level 4	Details
[System Information]	[Machine Information]			Displays the [Model], [Serial Number], [Ink Type], [Firmware Version], and [MAC Address].
	[Network]			Sets the [Obtain IP Address Automatically], [IP Address], [Subnet Mask], and [Default Gateway] to connect the machine to a computer.
	[Units]			Sets the [Length] and [Temperature].
	[Language]			Sets the language. The language can be set to Japanese, English, French, Italian, German, Spanish (Europe), Spanish (South America), Portuguese (South America) or other.
	[Date/Time]			Sets the current year, month, day, hour, minute, and second.
	[Screen Brightness]			Sets the brightness of the operation panel's screen.
	[Screen Operation Sound]			Turns the operation sound of the operation panel on/off.

*1 This setting only appears when media is loaded.

About the Media Used

Types of Media

In this manual, the paper used for output is called "media." The two main types of media used in this machine are shown below.

- Roll media: Media wound onto a paper tube
- Sheet media: Media not wound onto a paper tube such as standard-size media

Various paper types of roll media and sheet media are selectable according to your purpose. For detailed information about each media, contact your media supplier.

Conditions for Usable Media

This machine cannot print on every kind of media. When selecting media, be sure to carry out testing in advance to make sure that satisfactory printing results are obtained.

Size

	54-inch model	30-inch model
Width *1	295 to 1,371 mm (11.7 to 54 in.)	182 to 762 mm
Cutable media thickness*1	0.08 to 0.22 mm (3.2 to 8.6 mil; depends on the material of the media)	
Maximum media thickness (including backing paper)*1	When performing printing only: 1.0 mm (39.4 mil) When performing cutting: 0.4 mm (15 mil)	
Maximum roll outer diameter	250 mm (9.8 in.)	
Paper tube (core) inner diameter	76.2 mm (3 in.) or 50.8 mm (2 in.)	

*1 Applies to both roll and sheet media

Maximum Roll Weight

- 54-inch model: 35 kg (77 lb.)
- 30-inch model: 30 kg (66 lb.)

MEMO

If using the take-up unit, this specification depends on the conditions of the take-up unit.

Other Conditions

Media such as the following cannot be used.

- Media whose end is attached to the paper tube (core)
- Media that is severely warped or that has a strong tendency to reroll
- Media that cannot withstand the heat of the media heating system
- Media whose paper tube (core) is bent or crushed
- Media that bends under its own weight when loaded
- Media on a sagging roll
- Media that is rolled unevenly

RELATED LINKS

- [P. 321 Printing/Cutting Area](#)

Take-up Unit

Take-up Unit Use Conditions

Never pull the media with excessive force.

If the media is pulled with excessive force, the protection function will activate and cause an error. Make sure to observe the following to prevent the media from being pulled with excessive force.

- Do not operate the manual switch on the take-up unit while leaving media secured with the loading lever.

It may cause an error because the media is pulled with excessive force.

Never use the automatic separation function for media.

If automatic cut-off of media is set in the software RIP, the media will be cut off after each page is printed. When continually printing and taking up multiple pages, disable the automatic cut-off function in the software RIP. If the media is separated, take-up will be interrupted at that point.

MEMO

Perforated sheet cutting can be set with the software RIP. With this type of cutting, the media is not separated, so the take-up unit can be used.

About the Paper Tube

Paper tubes are consumable items.

Paper tubes are components that wear out. Although replacement timing will vary depending on use, watch the condition of the paper tube and replace at an appropriate time so that the media can be taken up in good working order.

Use the paper tube of the media you are using. To purchase the included paper tube, contact your authorized Roland DG Corporation dealer or visit our website (<https://www.rolanddg.com/>).

Basic Operations

Power Supply Operations	25
Turning the Power On	25
Turning the Power Off	26
Precautions When Operating the Power Supply	28
Sleep Mode (Power-saving Feature)	29
Setup of New Media	30
Setup of Roll Media	30
Setup of Sheet Media	53
Setup of Registered Media	67
Setup of Roll Media	67
Setup of Sheet Media	88
Checking before Output	100
LAN (Local Area Network) Settings	100
Preventing Sedimentation in Inks	101
Pausing and Canceling Output	102
Pausing and Resuming Output	102
Canceling Output	103
Separating the Media	104
Removing Media from the Take-up Unit	106
Ink Pouch Replacement	108
Out-of-ink Warnings	108
Ink Pouch Replacement	109
Cleaning Liquid Pouch Replacement	112
Out-of-cleaning-liquid Warnings	112
Cleaning Liquid Pouch Replacement	113

Power Supply Operations

Turning the Power On

⚠ WARNING

Remove any loaded media or switch off the sub power when printing is not being performed. The continued application of heat at a single location may cause the release of toxic gases from the media or pose a fire hazard.

Procedure

1. Close the front cover.
2. Turn on the main power switch.

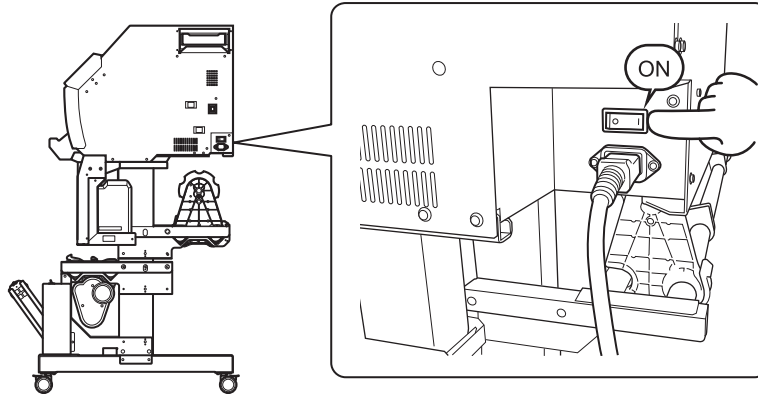

3. Tap the operation panel.

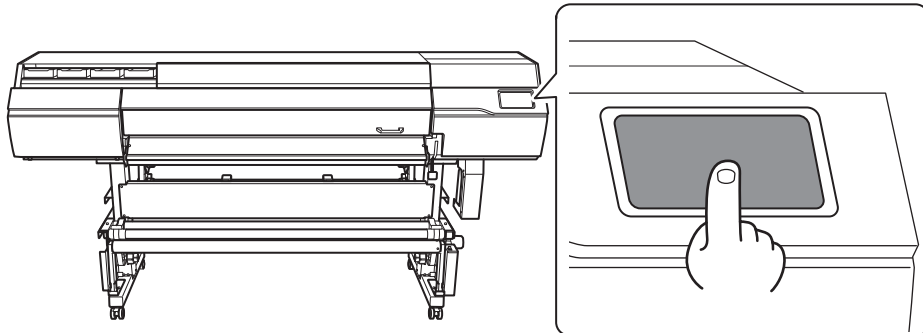

4. When instructions appear on the screen, tap the operation panel again.
The power to the operation panel is switched on.

Turning the Power Off

⚠ WARNING

Remove any loaded media or switch off the sub power when printing is not being performed. The continued application of heat at a single location may cause the release of toxic gases from the media or pose a fire hazard.

Procedure

1. When printing is complete, tap  on the operation panel.

The confirmation screen appears.

2. Tap [Yes].

The sub power switches off automatically.

3. Raise the loading lever and remove the media.

If you will leave the sub power on while not using the machine, set it as shown below.

- Raise the loading lever.

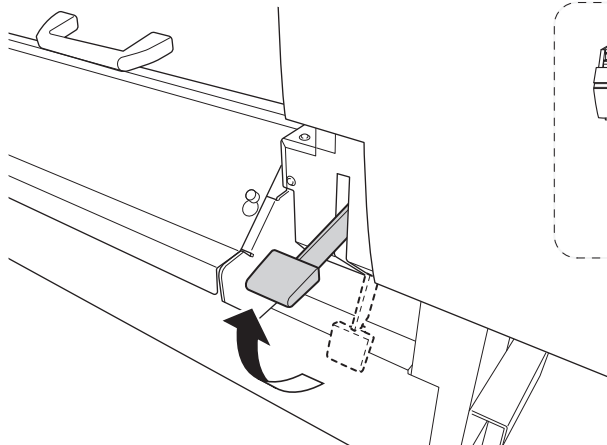

- Lower the dancer roller toward the rear.

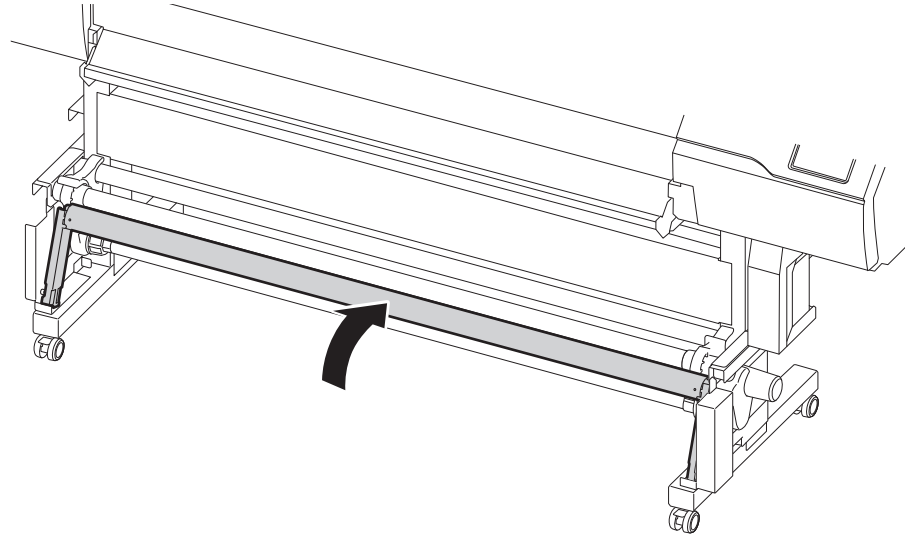

Precautions When Operating the Power Supply

Always keep the main power switched on.

Never switch off the main power. Leaving the main power enables automatic maintenance to be carried out periodically. If the automatic maintenance is not carried out, it may result in the breakdown of this machine, such as the breakdown of the print heads.

Never switch off the main power or unplug the power cord suddenly while operation is in progress.

Switching off the main power or unplugging the power cord suddenly while operation is in progress may damage the print heads. Be sure to first switch off the sub power. If the main power is accidentally switched off, immediately turn the main power and sub power back on.

Sleep Mode (Power-saving Feature)

This machine is provided with a power-saving feature that switches to a low-power "sleep mode" when a fixed interval passes with no operation. The factory default for the time after which the machine switches to sleep mode is 30 minutes. The operation panel turns off when the machine enters sleep mode. Using the operation panel or performing operations such as sending print data from the computer restores the machine to its normal mode.

This sleep mode setting can be changed. However, we recommend setting the activation time for sleep mode to 30 minutes or less to reduce power consumption and prevent problems such as overheating.

RELATED LINKS

- [P. 212 Setting the Activation Interval for Sleep Mode \(Power-saving Feature\)](#)

Setup of New Media

⚠ CAUTION

Do not touch the dancer roller needlessly.

The media take-up unit and feeder may move suddenly, which may result in injury.

Setup of Roll Media

Load the roll media on the printer. When the loading is finished, [Output possible.] is displayed as the status. This work is referred to as "Setup of Media."

⚠ CAUTION

Load the roll media correctly.

Otherwise the media may fall and cause injury.

⚠ CAUTION

The roll media is approximately 35 kg (77.2 lb.) (30-inch model: 30 kg [66.1 lb.]).

To avoid injury, handle the roll media with care.

⚠ CAUTION

Never load media that weighs over 35 kg (77.2 lb.) (30-inch model: 30 kg [66.1 lb.]).

The machine may fail to withstand the weight and tip over or cause the media to fall.

1. Install the media on the media holders.



The media holders of this machine are designed to be used with a paper tube (core) with an inner diameter of 2 inches or 3 inches.

⚠ WARNING

Handling roll media is an operation that must be performed by 2 persons or more, and care must be taken to prevent falls.

Attempting to lift heavy media in a manner that taxes your strength may cause physical injury. Also, if dropped, such items may cause injury.

Procedure

1. Tap  on the operation panel.
The sub power is switched on.
2. When using a take-up unit, use the following procedure to set it.
 - (1) Tap .
 - (2) Tap [Preferences]>[Take-up]>[Take-up Direction].

- (3) Select [Backward] or [Forward].
- (4) Tap [Save].
- (5) Tap  to go back to the original screen.

3. Open the front cover.

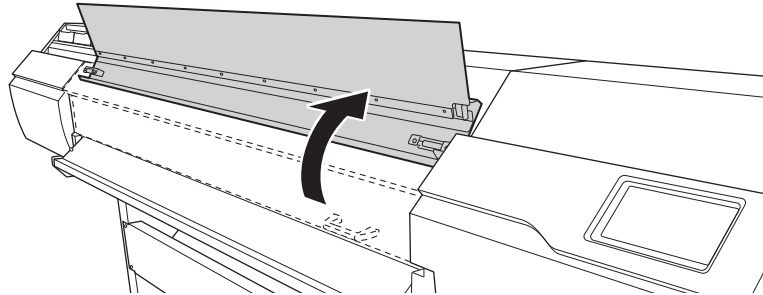

4. Move the media clamps to the outside of the grit rollers on the left and right edges respectively.

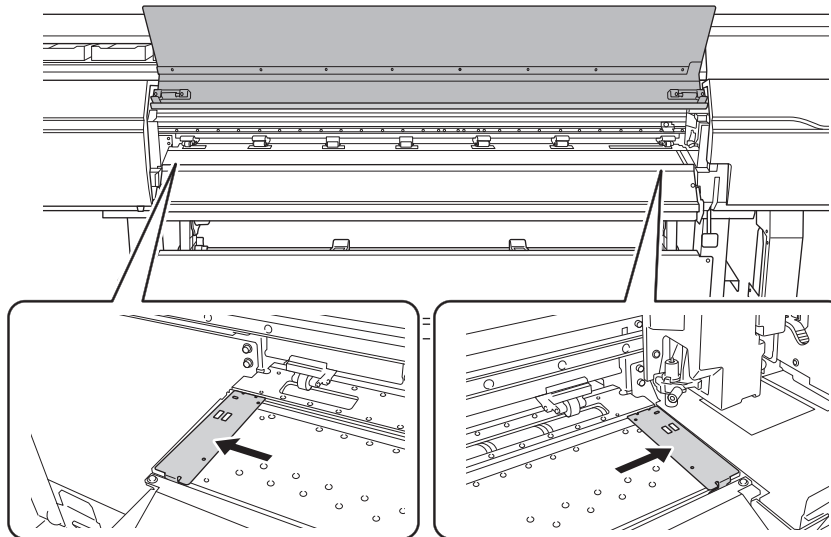

5. (Move to the rear of the printer.) Release the locking mechanisms of the media holders, and then draw them to the left and right ends respectively.

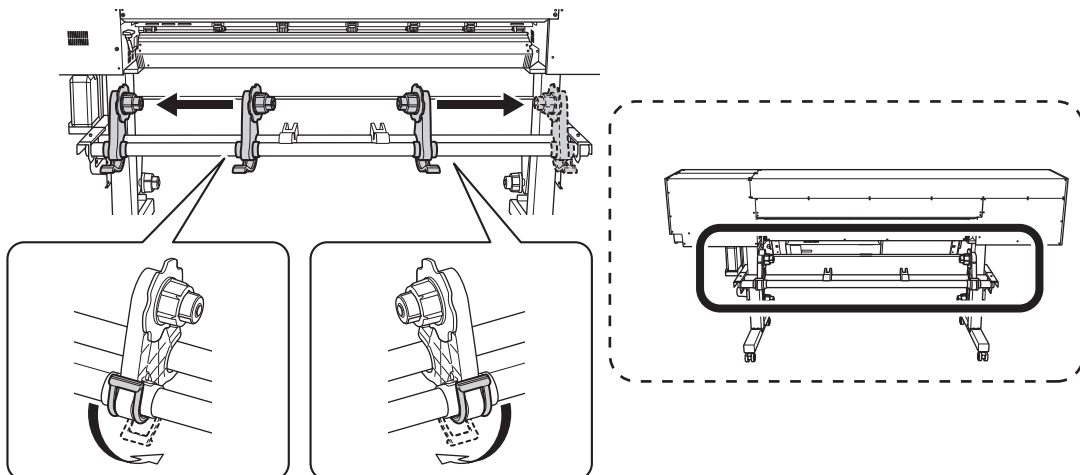

6. Place the media on the machine.

IMPORTANT

Do not leave media on the media stays or the pipes for a long period of time. The media may become deformed. Exercise caution.

- **Media with an outer diameter of 220 mm (8.66 in.) or less**

Place the media stays at positions that are 1/4 the length of the media from each end of the media, and then load the media.

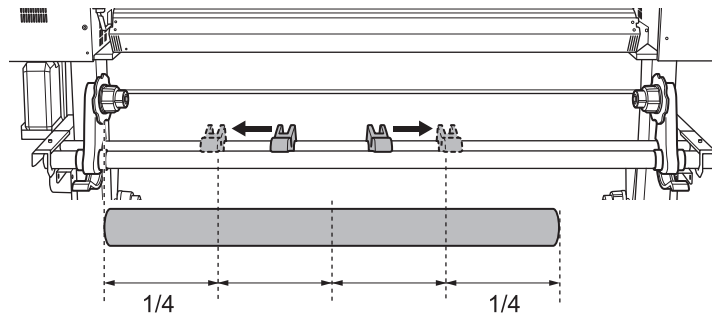

- **Media with an outer diameter exceeding 220 mm (8.67 in.)**

a. Rotate the media stays to draw them to the media holders.

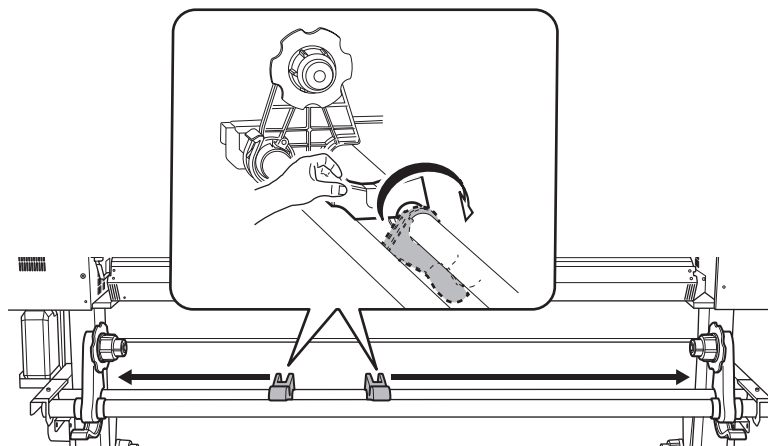

b. Place the media directly between the two pipes.

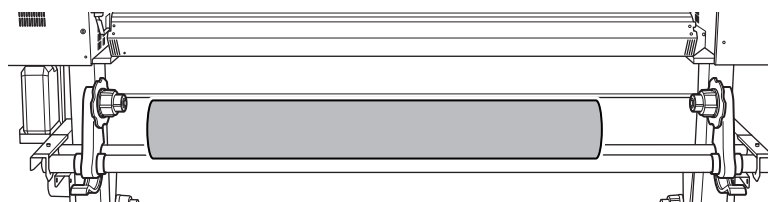

7. Fit the paper tube (core) of the media onto the end cap of the left media holder.

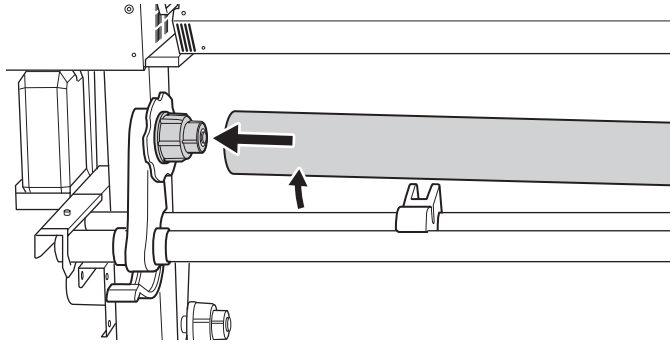

8. Move the right media holder to fit its end cap onto the paper tube (core) of the media. Fit the paper tube onto the media holders securely to prevent the media from moving easily.

IMPORTANT

Do not secure the media holders in place just yet.

In the following procedure, you will adjust the positions of the media holders before securing them in place. Do not secure them in place just yet.

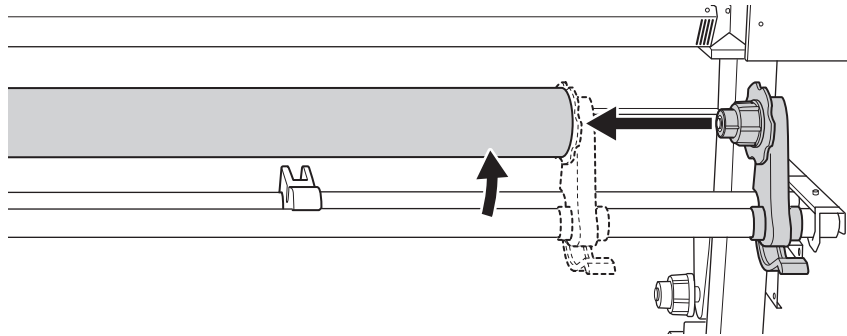

The next operation to perform varies depending on the media type and the Preferences. Proceed as shown below.

- For general media: 2. A: [Determine the positions of the media.](#) (P. 34)
- For transparent media or if [Preferences]>[Media Edge Detection] is set to [Disable]: 2. B: [Determine the positions of the media \(\[Media Edge Detection\]: \[Disable\]\).](#) (P. 39)

2. A: Determine the positions of the media.

This section describes how to use the suction fan to prevent media skewing. When using transparent media, whose edges cannot be detected, and when [Preferences]>[Media Edge Detection] is set to [Disable], the suction fan does not activate, so media cannot be loaded with this procedure. In these cases, refer to [2. B: Determine the positions of the media \(\[Media Edge Detection\]: \[Disable\]\).\(P. 39\)](#).

By default, [Skewing Correction Support at Setup] is set to [Enable].

Procedure

1. Determine the left and right positions of the media with the grit patterns used as the reference.

Note the following points when determining the positions.

- Hold the media holders from the outside and move them.
- Ensure that the left edge of the media is positioned so that it is within the range of the grit pattern of the left edge.
- Ensure that the right edge of the media is positioned so that it is within the range of one of the grit patterns.

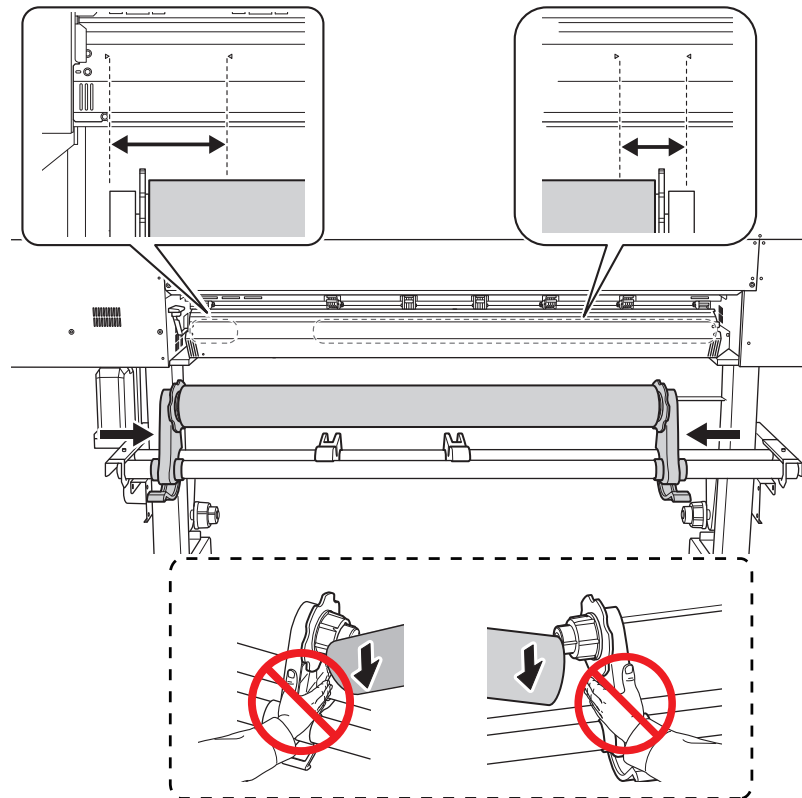

⚠ CAUTION

Do not hold places other than those instructed. Do not move the media by holding it directly.

Otherwise the media may fall off the media holder and cause injury.

IMPORTANT

Firmly decide the left and right side positions of the media at this point.

After this procedure is completed, if the left and right side positions do not fit the proper positions when securing the media with pinch rollers, you will have to go back to this step to redo this procedure. If you just

hold the media to readjust its position forcibly, the media will be skewed during printing, which will have an adverse effect on the printing results.

2. Secure the media holders.

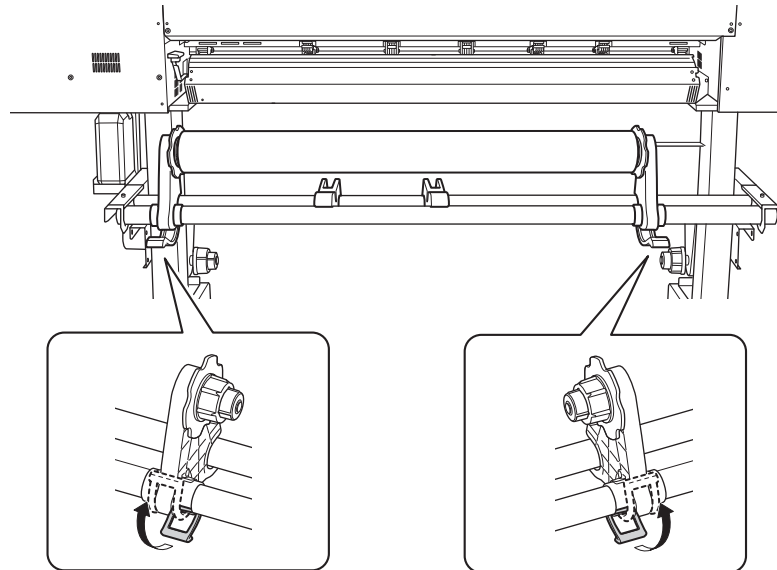

3. Use the following procedure to load the media.

Doing so will prevent media skewing.

- (1) Pass the leading edge of the media between the pinch rollers (A) and the grit rollers (B).

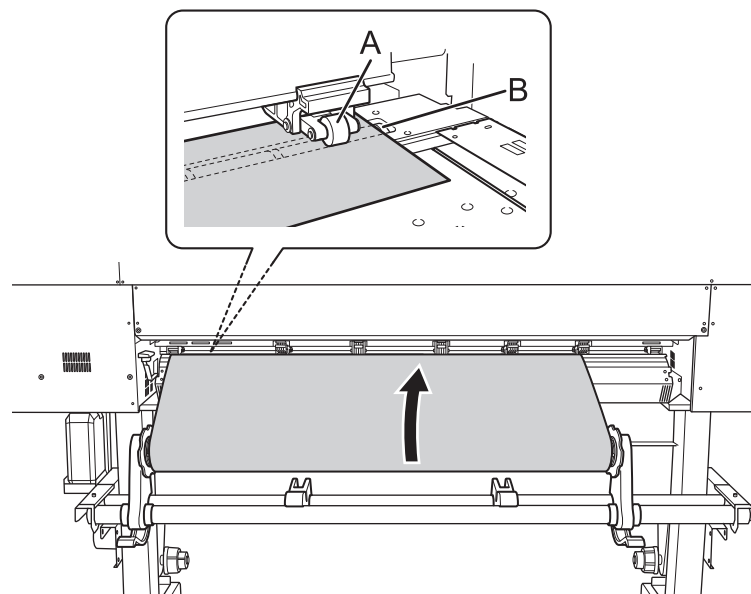

- (2) Feed the media until you hear a beep, and then additionally feed approximately 20 cm (7.87 in.) of the media.

You will hear a beep. Approximately 5 seconds later, you will hear two beeps, and then the suction fan will activate. While this fan is operating, the position of the media will be maintained even if you remove your hands from it.

- (3) Hold the media holder flange, turning it in the take-up direction to eliminate the slack in the media.

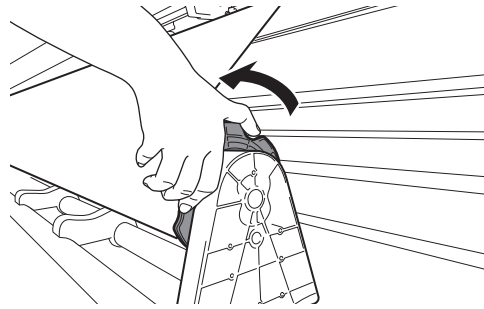

(4) Once the media is taut, additionally take up approximately 10 cm (3.94 in.) of media.

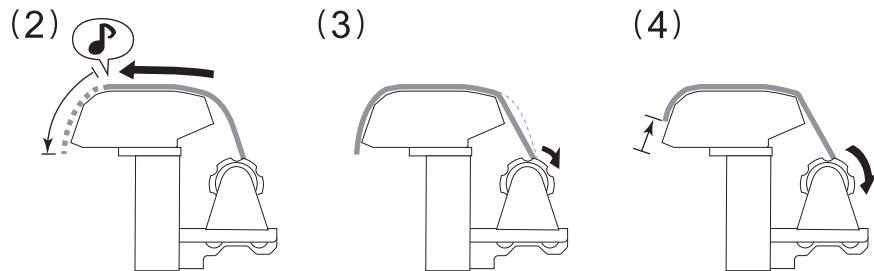

MEMO

If you take up too much media, you will hear two short beeps and the suction fan will stop. Take up the media, and then redo the procedure from step (1).

4. (Move to the front of the printer.) Make sure both edges of the media are above the grit rollers. Be sure to place the right edge of the media on the right-end grit roller.

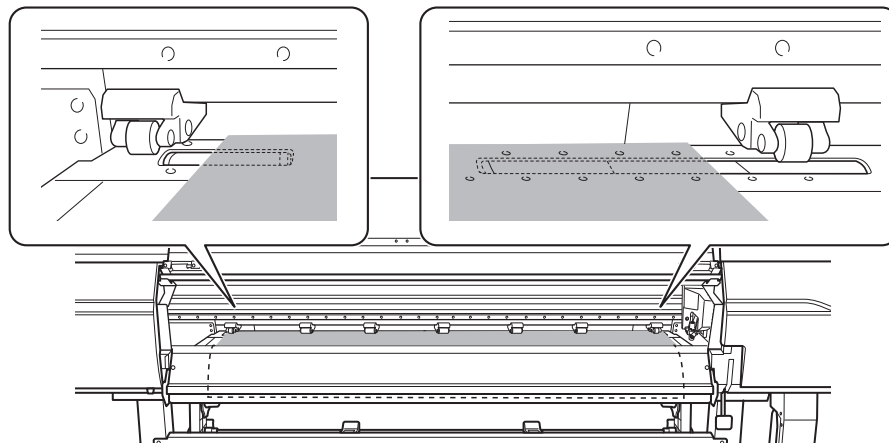

5. Move the left and right pinch rollers, placing them on both edges of the media. Position them approximately 10 mm (0.39 in.) from each edge of the media.

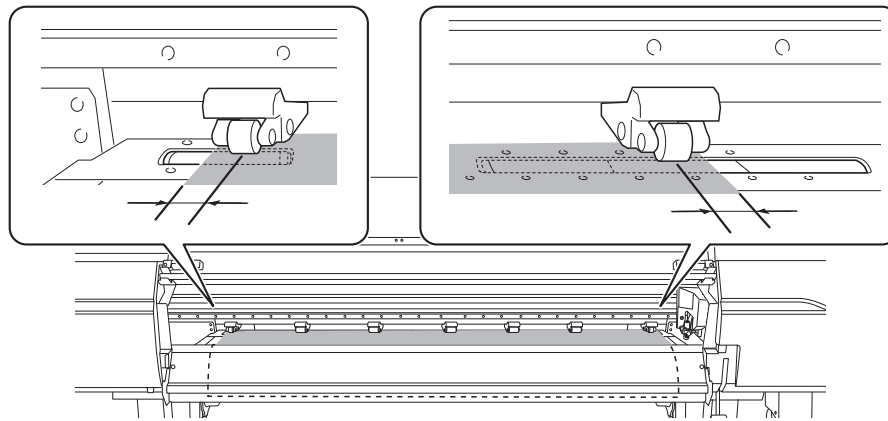
**IMPORTANT**

- Be sure to use the left and right pinch rollers. The force with which the media is pinched varies between the middle pinch rollers and the left and right pinch rollers. Using the middle pinch rollers to pinch the media edges will lead to unstable media feeding.
- If you want to readjust the media position, return to the back of the printer, release the media holders, and then redo the procedure from step 1. If you just stand at the front of the printer and hold the media to readjust its position forcibly, the media will be skewed during printing or will come loose, which will affect the printing quality.

MEMO

To smoothly move the pinch rollers, push down close to the rail.

- 6. Move the middle pinch rollers (B) over all the remaining grit rollers (A) covered by the media.**
There are grit patterns (C) wherever there are grit rollers.

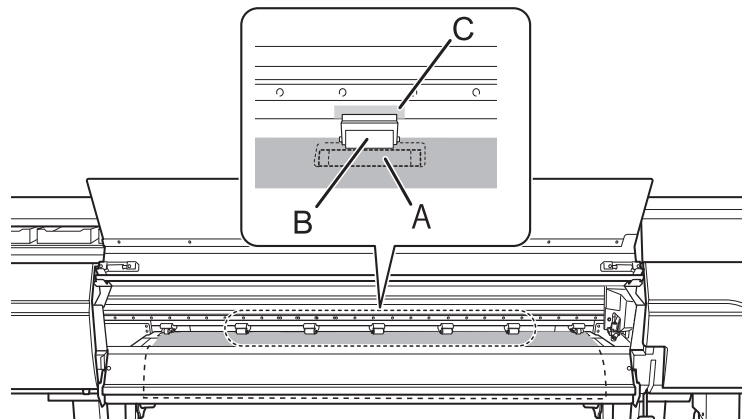
**IMPORTANT**

- Place the middle pinch rollers over all the grit patterns within the media width. If you have forgotten to place the middle pinch rollers, the media will be skewed during printing or will come loose, which will have an effect on the printing quality.
- The middle pinch roller will not lower onto the three grit rollers from the right end. Place the middle pinch roller on a grit roller other than these three.

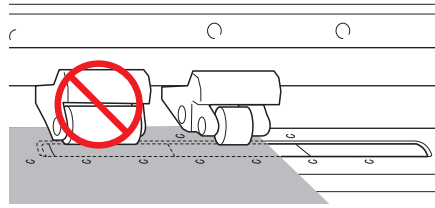

- There may be extra middle pinch rollers depending on the width of the media being used. Move the extra middle pinch rollers to positions where no grit patterns are present. Where no grit patterns are present, the middle pinch rollers will not come down.

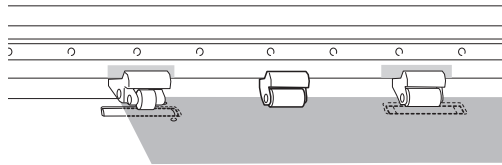

7. Lower the loading lever (front).

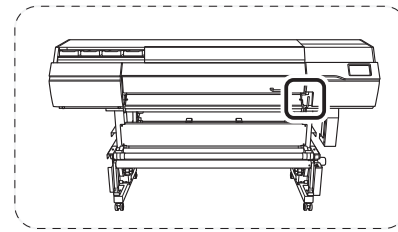
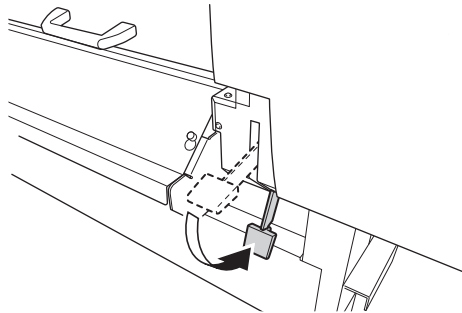

IMPORTANT

If you want to readjust the media position, return to the back of the printer, release the media holders, and then redo the procedure from step 1. If you just stand at the front of the printer and hold the media to readjust its position forcibly, the media will be skewed during printing or will come loose, which will affect the printing quality.

8. Line up the edges of the media with the centers of the holes of the left and right media clamps.

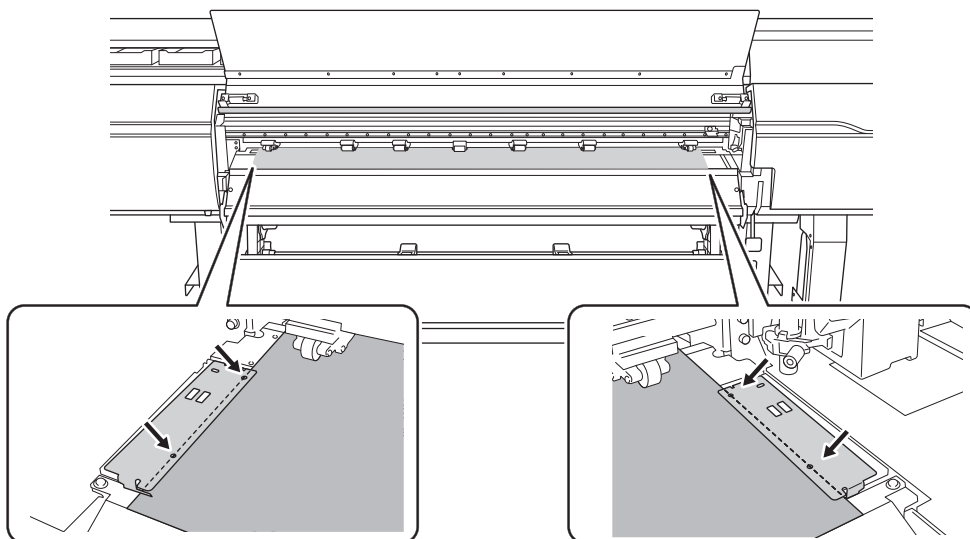

9. Close the front cover.

2. B: Determine the positions of the media ([Media Edge Detection]: [Disable]).

This section describes how to determine the positions of the media without using the suction fan. Refer to this information when using transparent media, whose edges cannot be detected, and when [Preferences]>[Media Edge Detection] is set to [Disable].

Procedure

1. Determine the left and right positions of the media with the grit patterns used as the reference.

Note the following points when determining the positions.

- Hold the media holders from the outside and move them.
- Ensure that the left edge of the media is positioned so that it is within the range of the grit pattern of the left edge.
- Ensure that the right edge of the media is positioned so that it is within the range of one of the grit patterns.

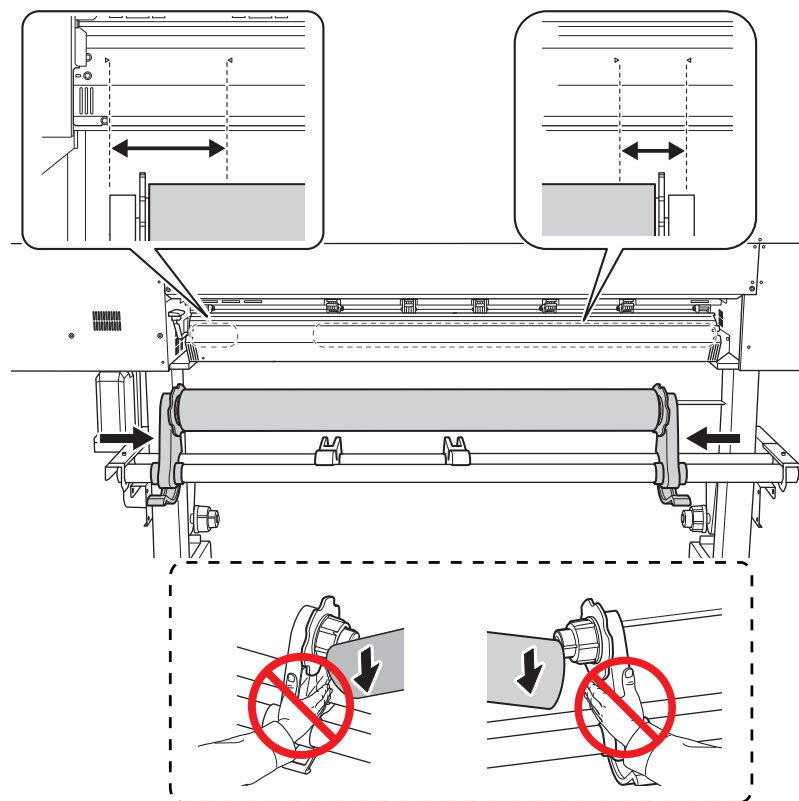

⚠ CAUTION

Do not hold places other than those instructed. Do not move the media by holding it directly.

Otherwise the media may fall off the media holder and cause injury.

IMPORTANT

Firmly decide the left and right side positions of the media at this point.

After this procedure is completed, if the left and right side positions do not fit the proper positions when securing the media with pinch rollers, you will have to go back to this step to redo this procedure. If you just hold the media to readjust its position forcibly, the media will be skewed during printing, which will have an adverse effect on the printing results.

2. Secure the media holders.

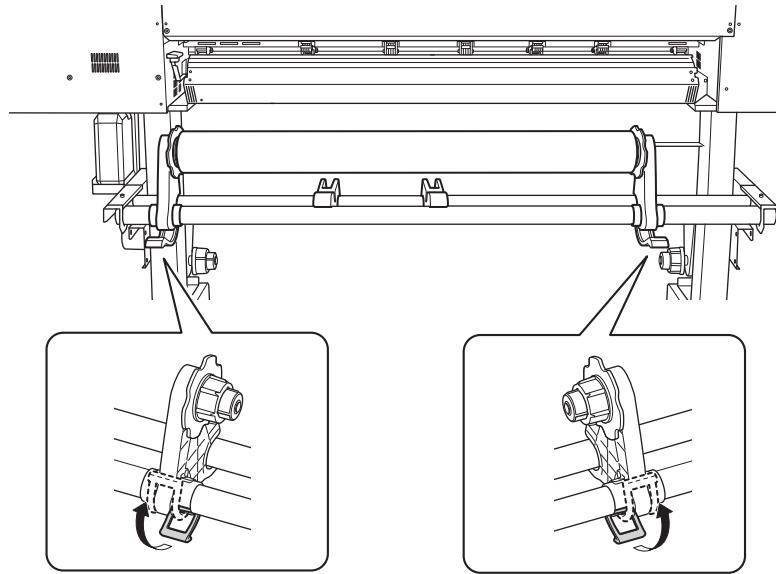

3. Pass the leading edge of the media between the pinch rollers (A) and the grit rollers (B).

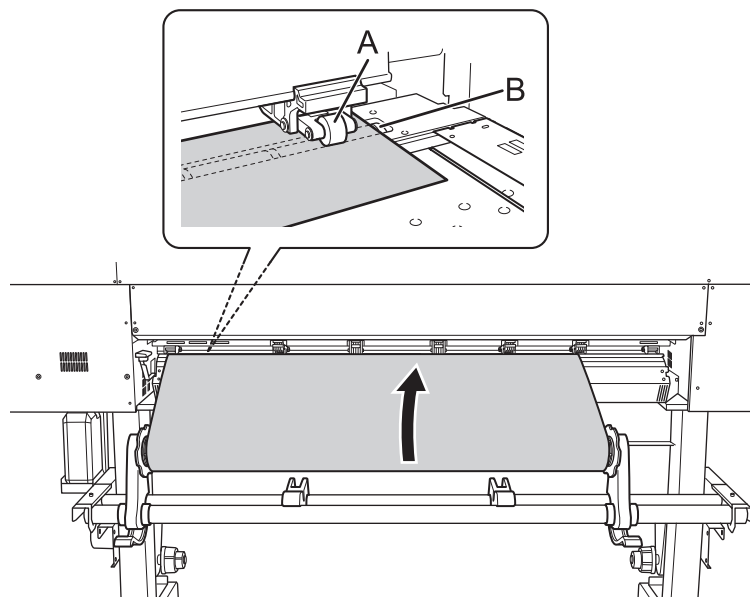

4. Lower the loading lever (rear).
The media is held in place.

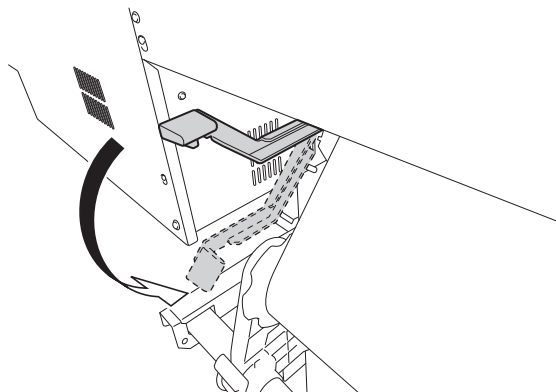

5. (Move to the front of the printer.) Gently hold down the media and raise the loading lever (front). The media is released.

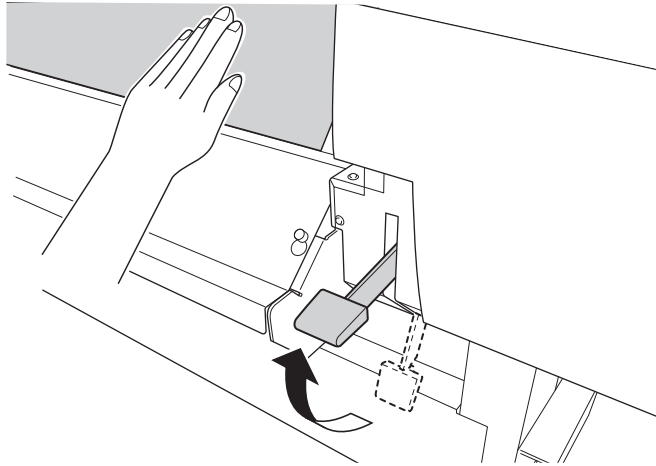

6. Pull out the media over the apron.

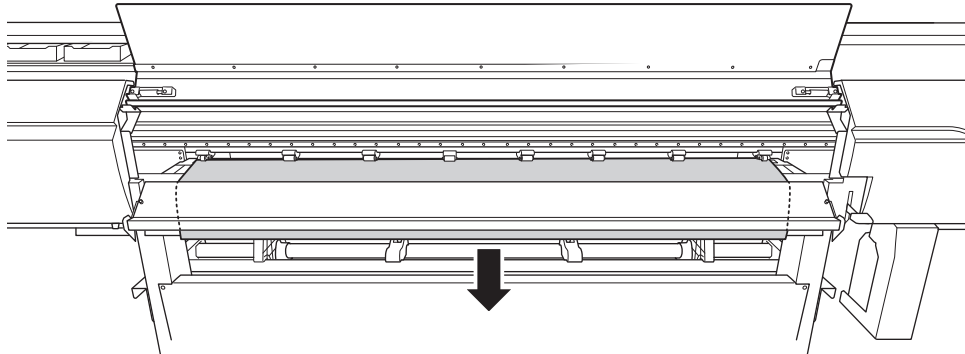

7. Make sure both edges of the media are above the grit rollers. Be sure to place the right edge of the media on the right-end grit roller.

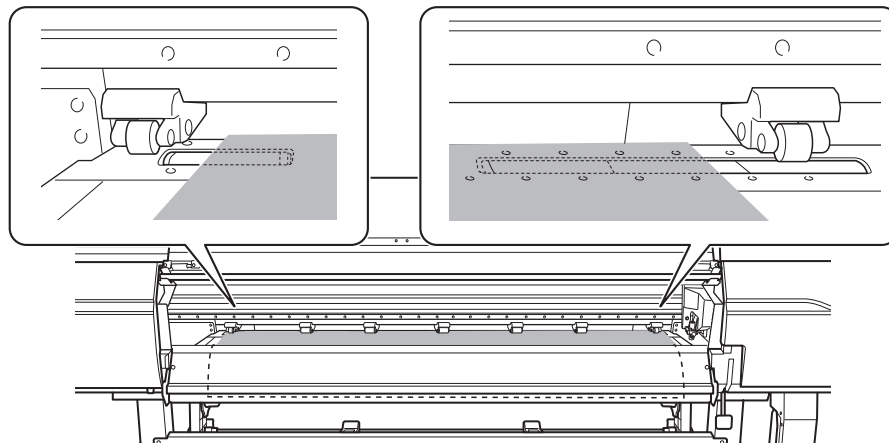

8. Move the left and right pinch rollers, placing them on both edges of the media. Position them approximately 10 mm (0.39 in.) from each edge of the media.

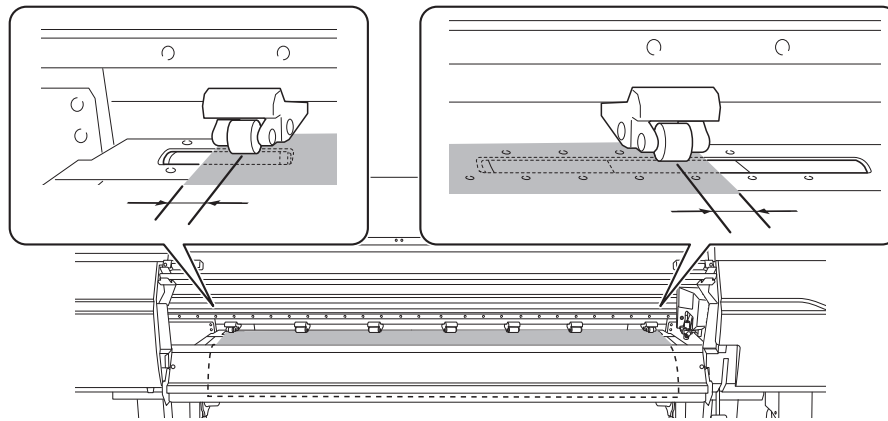

IMPORTANT

- Be sure to use the left and right pinch rollers. The force with which the media is pinched varies between the middle pinch rollers and the left and right pinch rollers. Using the middle pinch rollers to pinch the media edges will lead to unstable media feeding.
- If you want to readjust the media position, return to the back of the printer, release the media holders, and then redo the procedure from step 1. If you just stand at the front of the printer and hold the media to readjust its position forcibly, the media will be skewed during printing or will come loose, which will affect the printing quality.

MEMO

To smoothly move the pinch rollers, push down close to the rail.

9. Move the middle pinch rollers (B) over all the remaining grit rollers (A) covered by the media. There are grit patterns (C) wherever there are grit rollers.

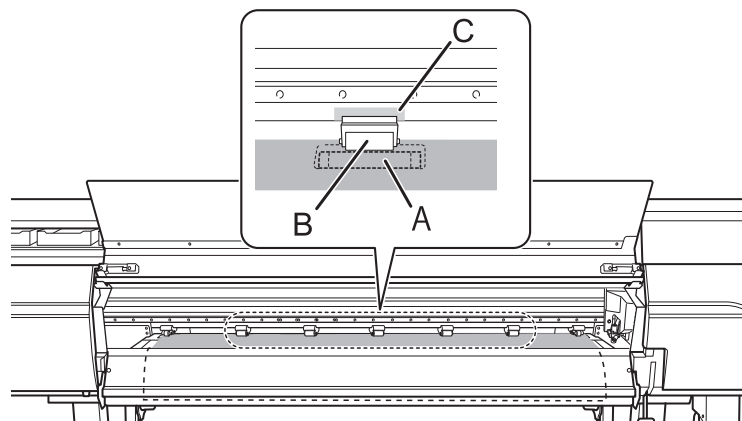

IMPORTANT

- Place the middle pinch rollers over all the grit patterns within the media width. If you have forgotten to place the middle pinch rollers, the media will be skewed during printing or will come loose, which will have an effect on the printing quality.
- The middle pinch roller will not lower onto the three grit rollers from the right end. Place the middle pinch roller on a grit roller other than these three.

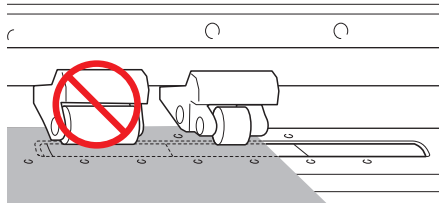

- There may be extra middle pinch rollers depending on the width of the media being used. Move the extra middle pinch rollers to positions where no grit patterns are present. Where no grit patterns are present, the middle pinch rollers will not come down.

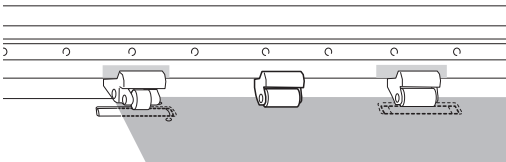

10. Hold the media at the center and pull it out, being sure to keep it straight and all areas of the media to be taut.

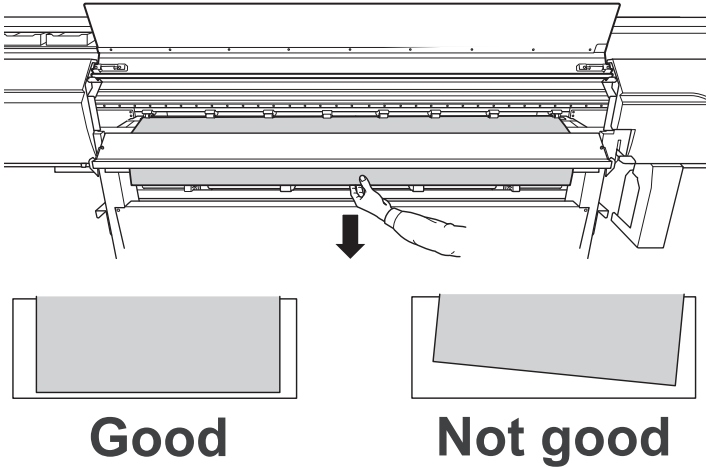

11. Lower the loading lever (front).

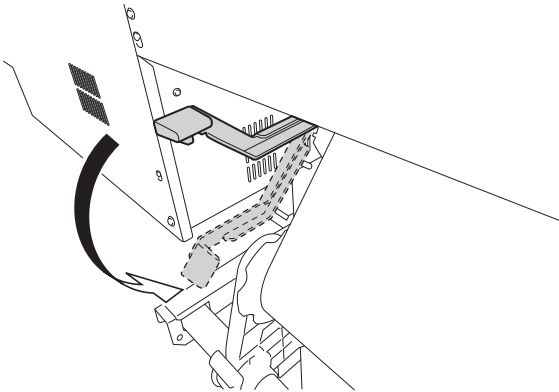

12. Line up the edges of the media with the centers of the holes of the left and right media clamps.

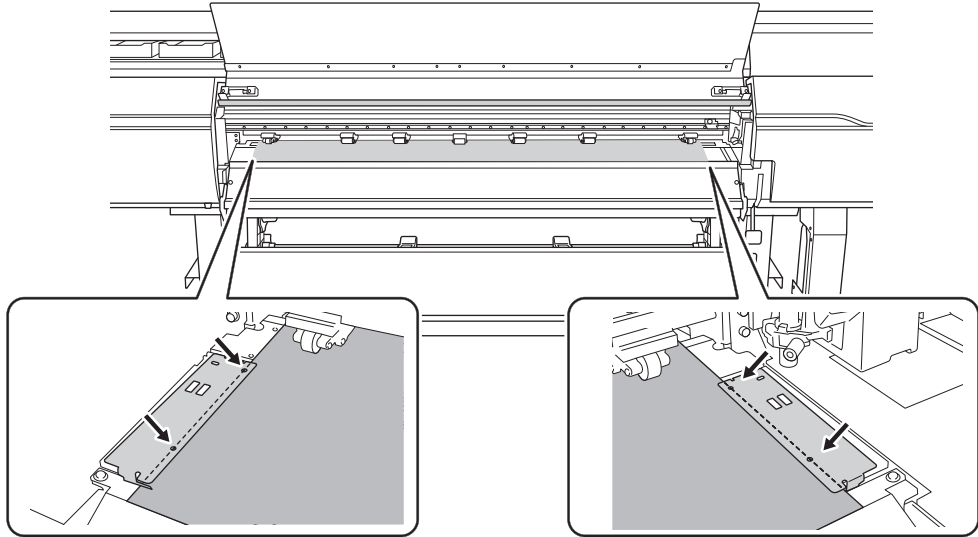

- 13. Close the front cover.

3. Register the media.

Procedure

1. Tap  [Setup].

2. Select [New].

3. Tap [Next].

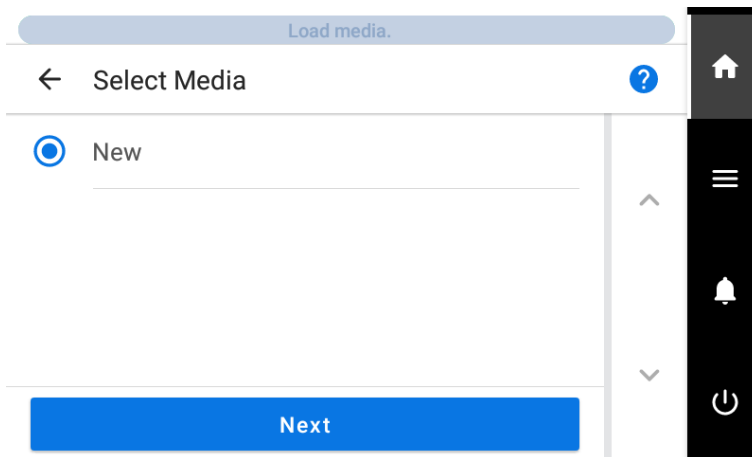

4. Enter a new media name and tap [OK].

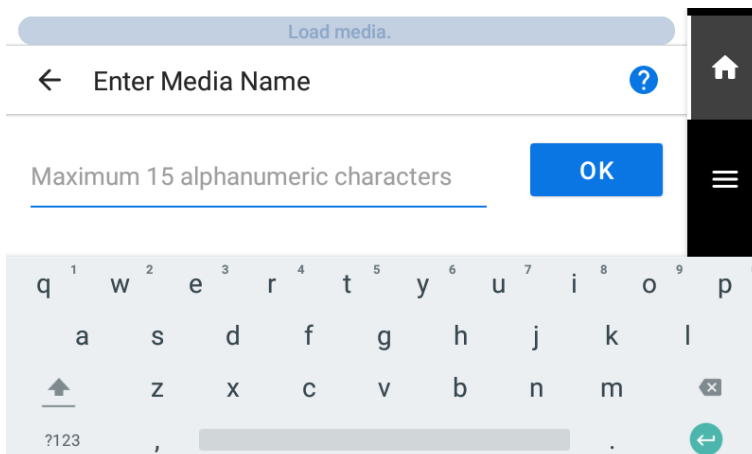

5. Tap [Next].

6. The [Setup Method] screen appears. Select whether to use the take-up unit.

7. Tap [Start Setup].

The cutting carriage moves and detects the width of the media and the positions of the media clamps. This operation is called initialization.

8. When [The media could not be detected automatically. Manually set the printing area.] appears, use the following procedure to configure the settings.

MEMO

This message may appear when media with high reflectance is set up.

(1) Tap [OK].

(2) Tap [Change].

The [Set the right edge of the printing area within the area specified by the pinch rollers.] screen appears.

(3) Hold down  to move the center of the blade (A) approximately 2 mm (0.08 in.) to the inside (B) from the left edge of the right pinch roller.

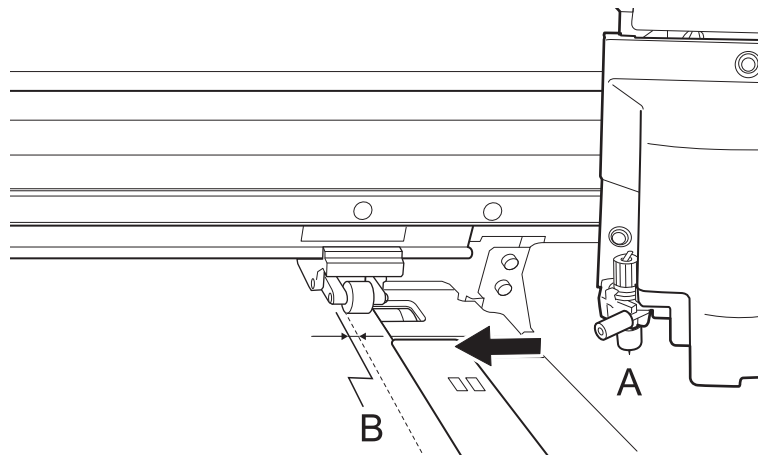

(4) Tap [OK].

The [Set the left edge of the printing area within the area specified by the pinch rollers.] screen appears.

(5) Hold down  to move the center of the blade (A) approximately 2 mm (0.08 in.) to the inside (B) from the right edge of the left pinch roller.

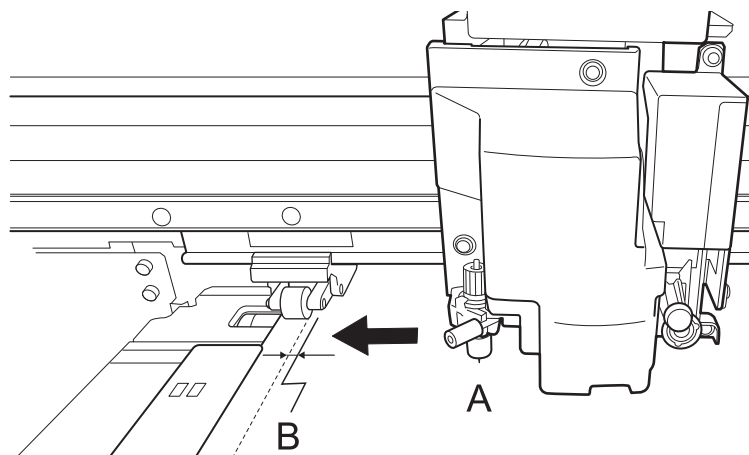

(6) Tap [OK].

The set left and right positions are applied to the [Printing Area (Width)].

(7) Tap [OK].

4. Load the media in the take-up unit.

If you will not use the take-up unit, proceed to [5. Configure settings to match the media.](#) (P. 51).

Procedure

1. Lower the dancer roller toward the rear.

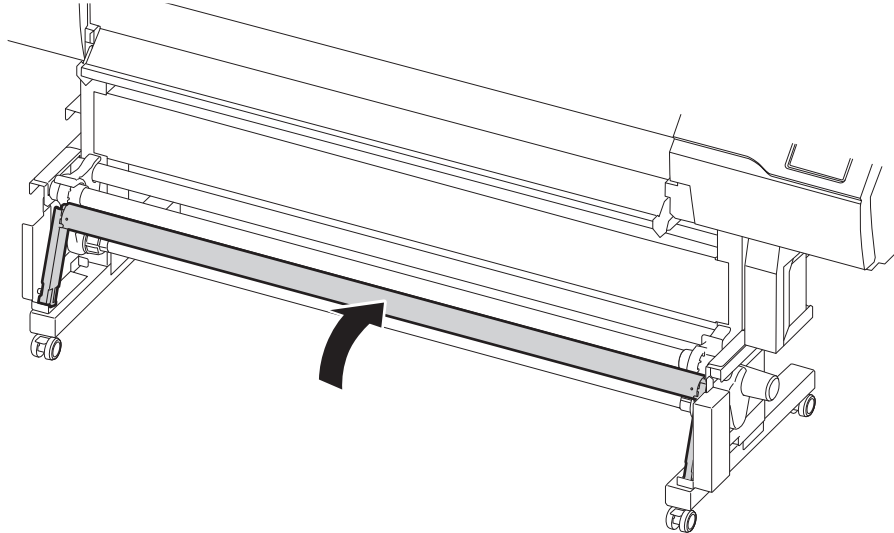

2. Follow the procedure below to load a paper tube on the media holders of the take-up unit.
Prepare a paper tube wider than the media that has been set up.

IMPORTANT

Paper tubes are consumable items.

Watch the condition of the paper tube and replace at an appropriate time so that the media can be taken up in good working order.

- (1) Release the media holders to enable their movement.

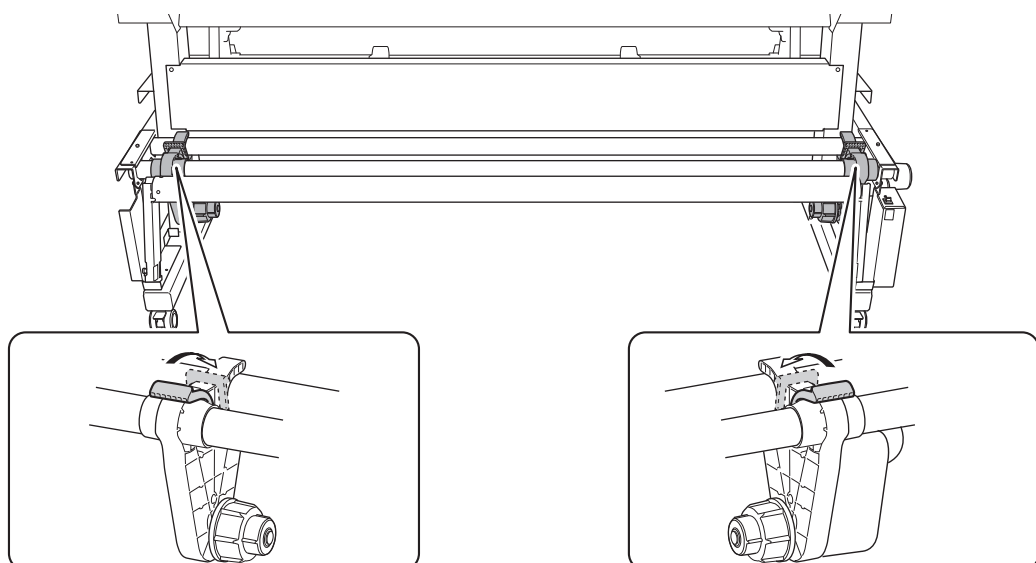

- (2) Fit the paper tube onto the right end cap.
Fit the paper tube securely right to the end of the end cap.
- (3) Push the left media holder into the paper tube.

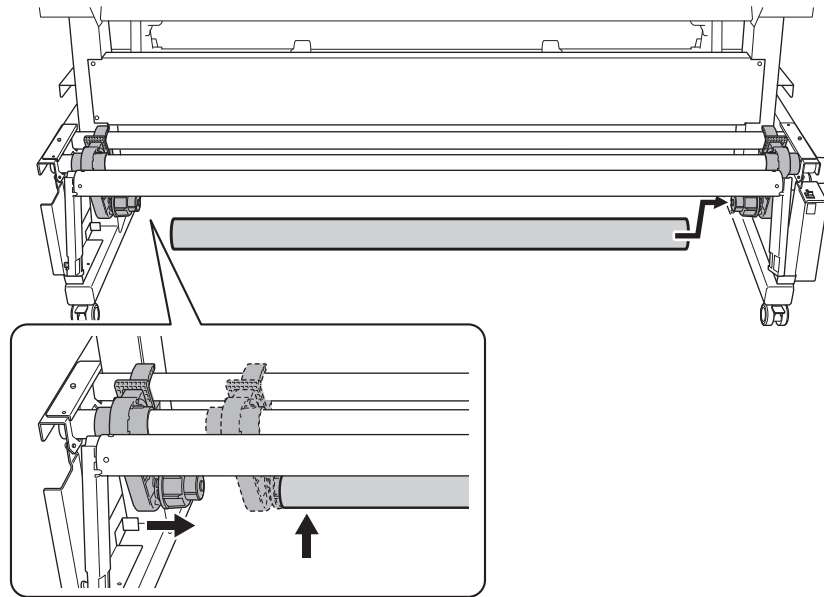

3. Hold down  on the operation panel to feed out the media until the tip of the media reaches the paper tube.

Media is fed out 10 mm (0.39 in.) each time you hold down this button. Holding down the button lets you feed out paper continuously.

Good

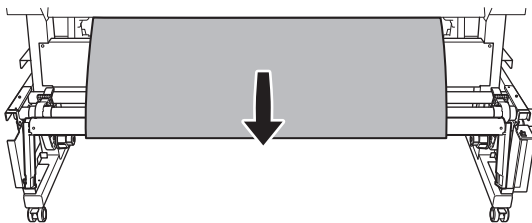

Not Good

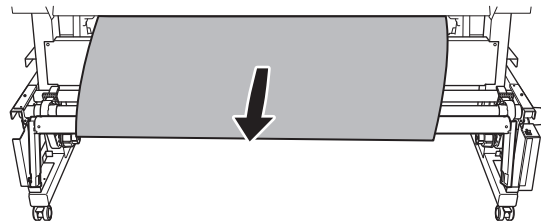

MEMO

Feed out the media until it can wrap around at least 1/4 of the paper tube.

When using the FORWARD setting	When using the BACKWARD setting

4. Follow the procedure below to adjust the positions of the media holders.
- (1) Move both media holders so that it is possible to see the paper tube from the right edge of the media.
 - Hold the media holders from the outside and move them.
 - Adjust the positions so media is taken up in the center of the paper tube.

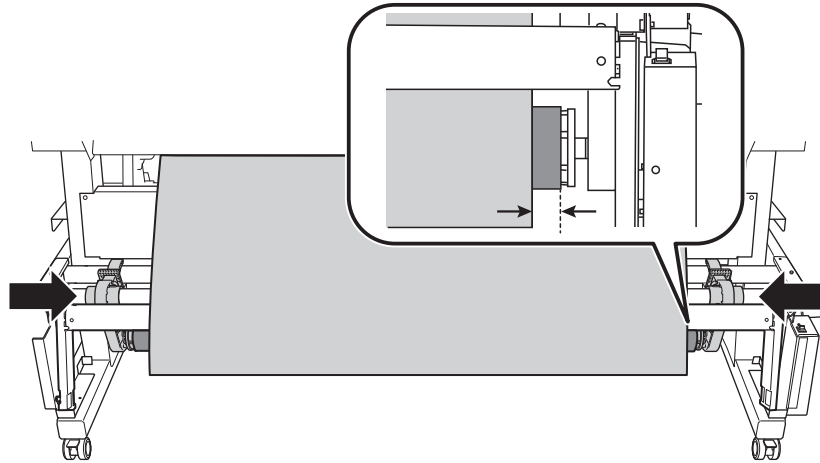

(2) Secure the left and right media holders.

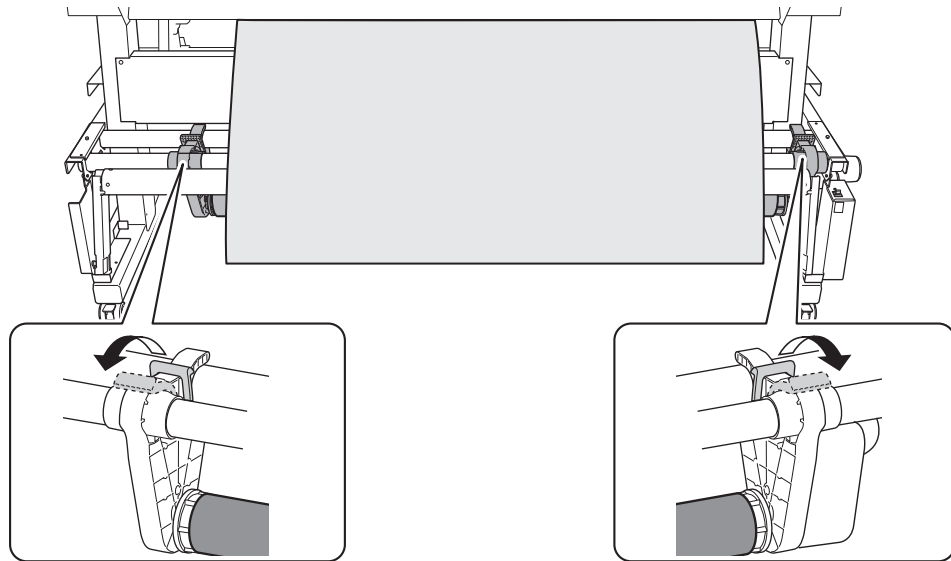

5. Follow the procedure below to secure the media on the paper tube.

Secure the media in the [Take-up Direction] set in step 2 of 1. [Install the media on the media holders.](#) (P. 30).

- (1) While pulling the media so that it does not sag, secure the center of the media on the paper tube with adhesive tape.
- (2) While pulling the media from the center toward the outer edges, secure the left and right edges of the media on the paper tube with adhesive tape.

- When using the FORWARD setting

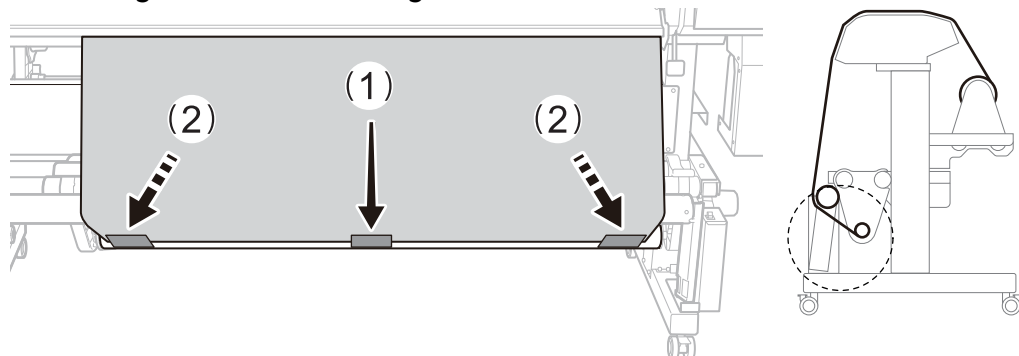

- When using the BACKWARD setting

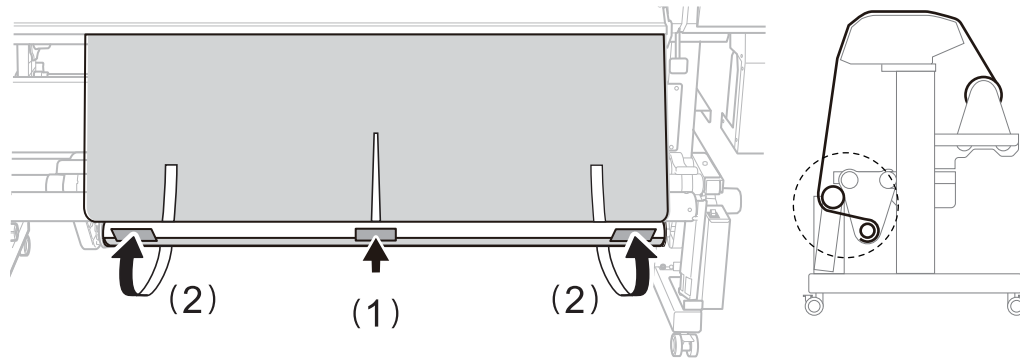

6. Tap [OK].
A small amount of the media is fed out.
7. Lower the dancer roller toward the front.

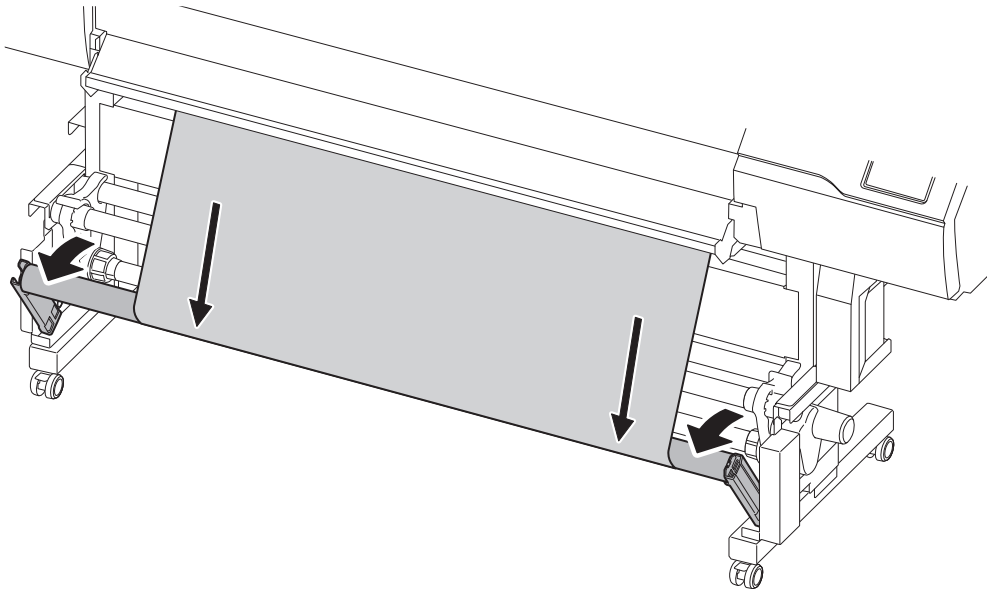



8. Tap [OK].

5. Configure settings to match the media.

To ensure the optimal output according to the media size and type, set the minimal amount of items. All items set here can be set individually as well.

Procedure

1. On the [Select Media Output Type] screen, select the output type and tap [Next].
 - [Print Only/Print & Cut]
Proceed to step 2.
 - [Cut Only]
Switch to the [Multi Sensor Adjustment] screen. When automatic adjustment is finished, tap [OK]. This completes the settings for [Cut Only].

2. On the [Heater Temperature] screen, adjust the [Print Heater] and [Dryer] temperatures.
 - If this is not necessary, tap [Next].
 - Follow the procedure below to make changes.
 - a. Tap  or  to set the [Print Heater] or [Dryer] temperature.
 - b. Tap [Next].

3. Use the [Print Head Height] screen to adjust the print head height.
 - If this is not necessary, tap [Next].
 - Follow the procedure below to make adjustments.
 - a. Tap [Change]
 - b. Open the front cover.
 - c. Move the height-adjustment lever to adjust the head height.
 - d. Close the front cover.
 - e. Tap [OK].
 - f. Tap [Next].
 For details on this work, refer to [Changing the Print Head Height\(P. 153\)](#).

4. On the [Nozzle Drop-out Test] screen, configure the [Printing Test] and [Output Start Location] settings.
 - If this is not necessary, tap [Next].
 - To perform a [Printing Test], tap [Printing Test]>[Execute]. For details on what to do after the printing test, refer to [Step 2: Normal Cleaning Method\(P. 118\)](#).

5. On the [Select Media Adjustment Method] screen, select the adjustment method.
Here, the media feed correction for reducing horizontal bands and the correction of the landing position of the ink will be adjusted.

MEMO

[Simple Correction (Auto)] is the recommended adjustment. You can determine the correction values with [Detailed Correction (Manual)].

- Follow the procedure below to make automatic adjustments.
 - a. Tap [Simple Correction (Auto)]>[Next].
 - b. Tap [Execute] on the [Batch Automatic Correction] screen.

On successful completion of automatic adjustment, the home screen appears. This completes the settings.

For more information, refer to [Automatically Making Required Adjustments\(P. 148\)](#).

- **Follow the procedure below to make manual adjustments.**
 - a. Tap [**Detailed Correction (Manual)**] > [**Next**].
 - b. Tap [**Execute**] on the [**Multi Sensor Adjustment**] screen.

Adjust the reading sensor to the optimal condition. If the adjustment failed, respond to the failure according to the information in [Correcting the Reading Sensor\(P. 193\)](#).
 - c. Tap [**Next**].
 - d. Perform a printing test on the [**Detailed Feed Correction (Manual)**] screen.

Set the correction value from the printing test result. For more information, refer to [Manual Adjustment: Reducing Horizontal Bands \(Feed Correction Function\)\(P. 149\)](#).
 - e. Tap [**Save and Proceed**].
 - f. Perform a printing test on the [**Detailed Media Gap Adjustment (Manual)**] screen.

Set the correction values from the printing test result. For more information, refer to [Manual Adjustment: Adjusting the Misalignment of the Ink Landing Position \(Media Gap Adjustment\)\(P. 151\)](#).
 - g. Tap [**Save and Exit**].

IMPORTANT

When printing and cutting or just cutting, rewind the media from the take-up device to slacken the media.

If sufficient media is not wound on the paper tube immediately after setup, this operation may not be performed well, lowering the cutting quality and preventing continued take-up. When performing cutting immediately after attaching the media to the paper tube, first feed enough media to carry out take-up a few times and set the base point.

This completes the setup of the media.

Setup of Sheet Media

Load the sheet media on the printer. When the loading is finished, [Output possible.] is displayed as the status. This work is referred to as "Setup of Media."

1. A: Determine the positions of the media.

When using transparent media, whose edges cannot be detected, and when [Preferences]>[Media Edge Detection] is set to [Disable], the suction fan does not activate, so media cannot be loaded with this procedure. In these cases, refer to [1. B: Determine the positions of the media \(\[Media Edge Detection\]: \[Disable\]\)](#). (P. 58).

By default, [Skewing Correction Support at Setup] is set to [Enable].

Procedure

1. Tap  on the operation panel.
The sub power is switched on.
2. Open the front cover.
3. Move the media clamps to the outside of the grit rollers on the left and right edges respectively.

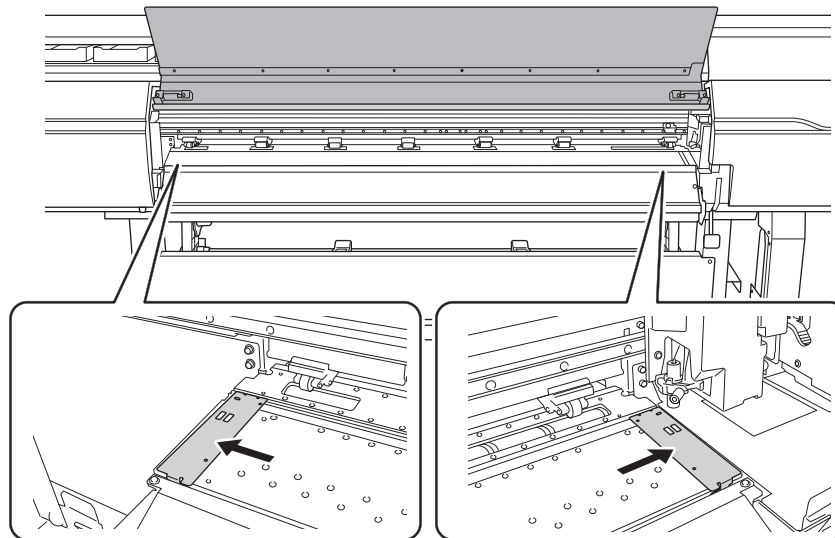

4. (Move to the rear of the printer.) Release the locking mechanisms of the media holders, and then draw them to the left and right ends respectively.

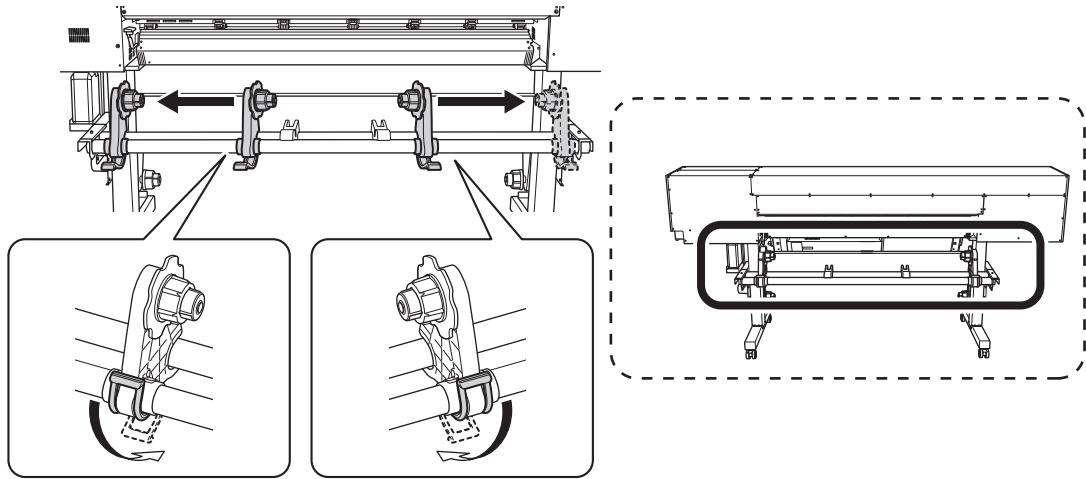

5. From the rear of the printer, pass the leading edge of the media between the pinch rollers (A) and the grit rollers (B).

You will hear a beep. Approximately 5 seconds later, you will hear two beeps, and then the suction fan will activate. While this fan is operating, the media will not move backward even if you remove your hands from it.

When loading the media from the front of the printer, feed the leading edge of the media (the side where printing will start) over the platen, and then pull the media to the front to activate the suction fan.

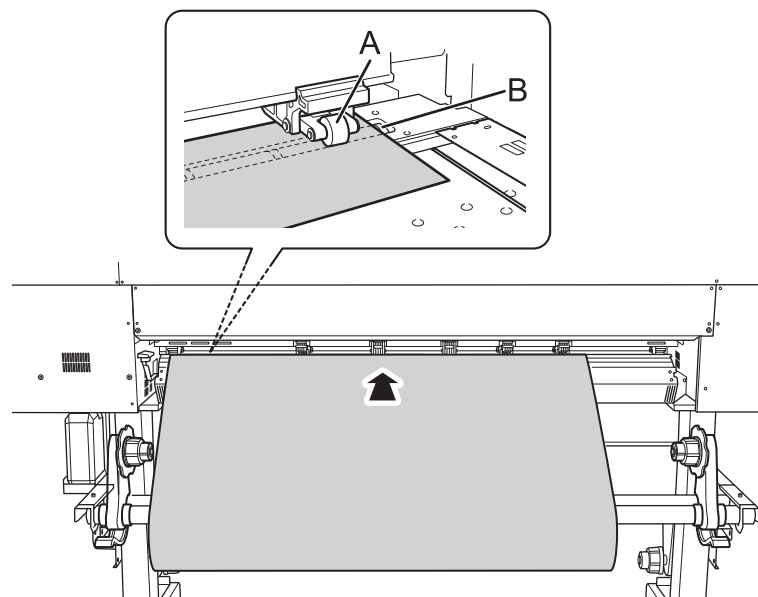

6. (Move to the front of the printer.) Make sure both edges of the media are above the grit rollers. Be sure to place the right edge of the media on the right-end grit roller.

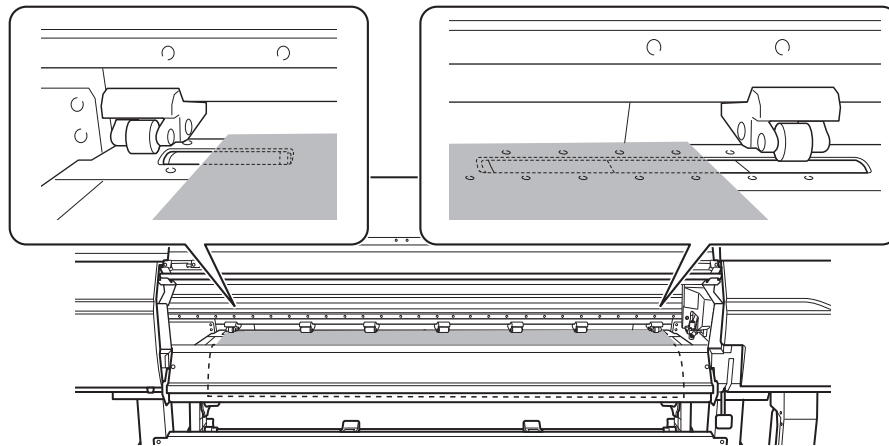

- 7. Move the left and right pinch rollers, placing them on both edges of the media.**
Position them approximately 10 mm (0.39 in.) from each edge of the media.

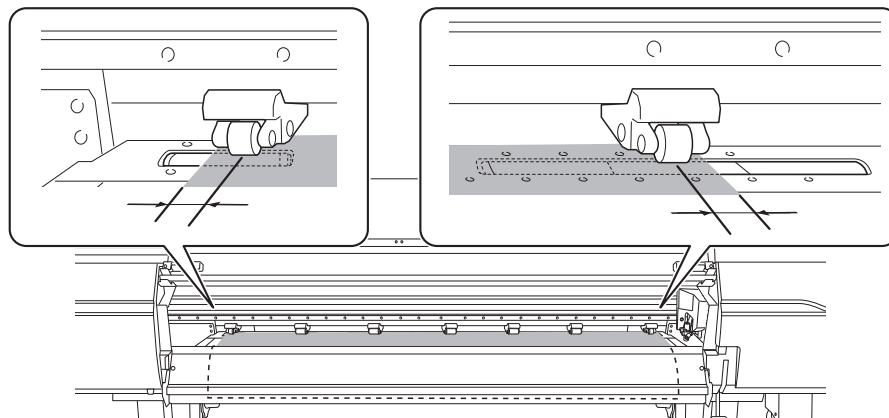

IMPORTANT

- Be sure to use the left and right pinch rollers. The force with which the media is pinched varies between the middle pinch rollers and the left and right pinch rollers. Using the middle pinch rollers to pinch the media edges will lead to unstable media feeding.
- If you want to readjust the media position before securing it in place, redo the procedure from step 5.

MEMO

To smoothly move the pinch rollers, push down close to the rail.

- 8. Move the middle pinch rollers (B) over all the remaining grit rollers (A) covered by the media.**
There are grit patterns (C) wherever there are grit rollers.

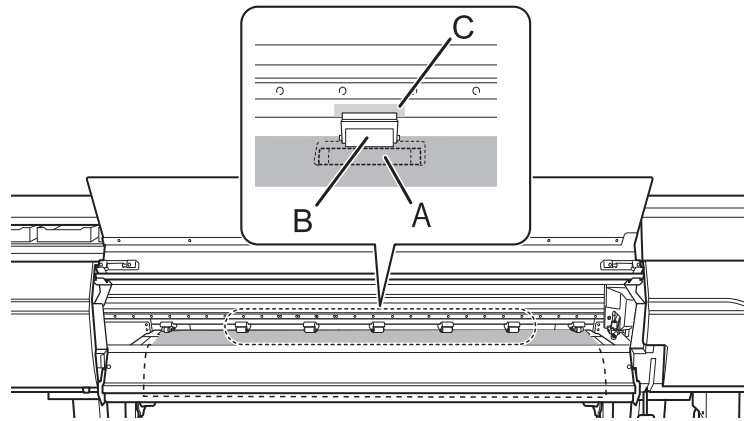

IMPORTANT

- Place the middle pinch rollers over all the grit patterns within the media width. If you have forgotten to place the middle pinch rollers, the media will be skewed during printing or will come loose, which will have an effect on the printing quality.
- The middle pinch roller will not lower onto the three grit rollers from the right end. Place the middle pinch roller on a grit roller other than these three.

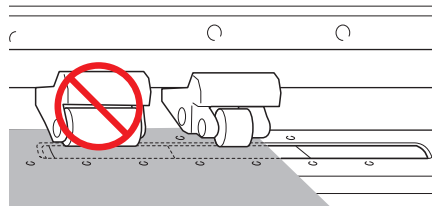

- There may be extra middle pinch rollers depending on the width of the media being used. Move the extra middle pinch rollers to positions where no grit patterns are present. Where no grit patterns are present, the middle pinch rollers will not come down.

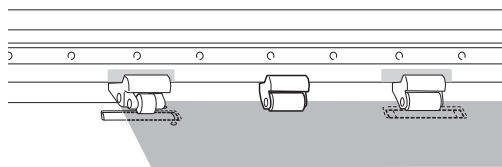

9. Lower the loading lever (front).

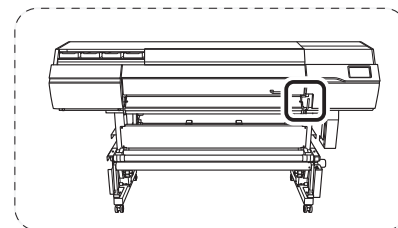
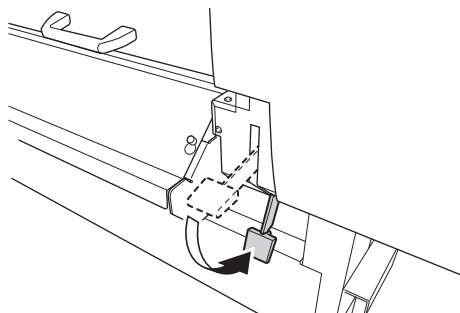

IMPORTANT

If you want to readjust the media position before securing it in place, redo the procedure from step 5.

10. Line up the edges of the media with the centers of the holes of the left and right media clamps.

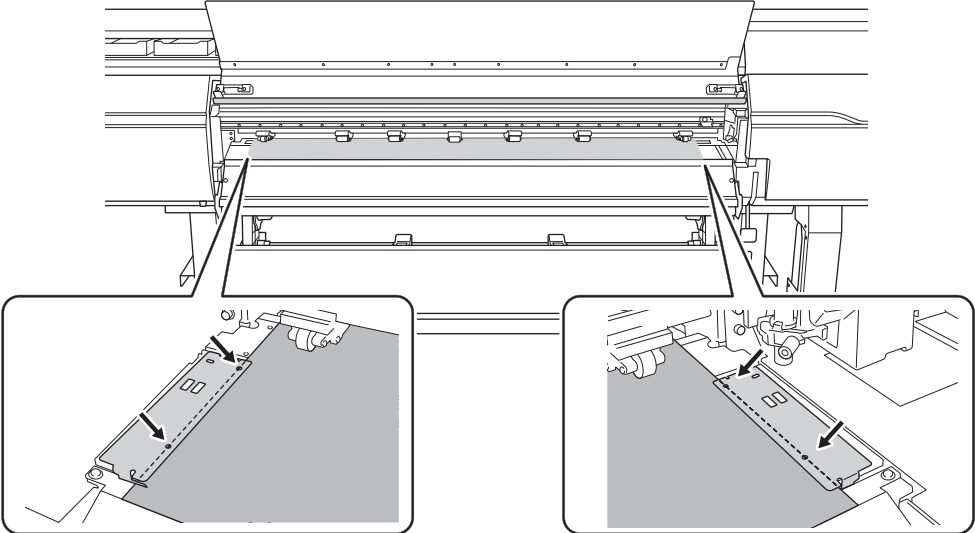

11. Close the front cover.

1. B: Determine the positions of the media ([Media Edge Detection]: [Disable]).

Use the following procedure to determine the positions of the media when using transparent media, whose edges cannot be detected, and when [Preferences]>[Media Edge Detection] is set to [Disable].

Procedure

1. Tap  on the operation panel.

The sub power is switched on.

2. Open the front cover.

3. Move the media clamps to the outside of the grit rollers on the left and right edges respectively.

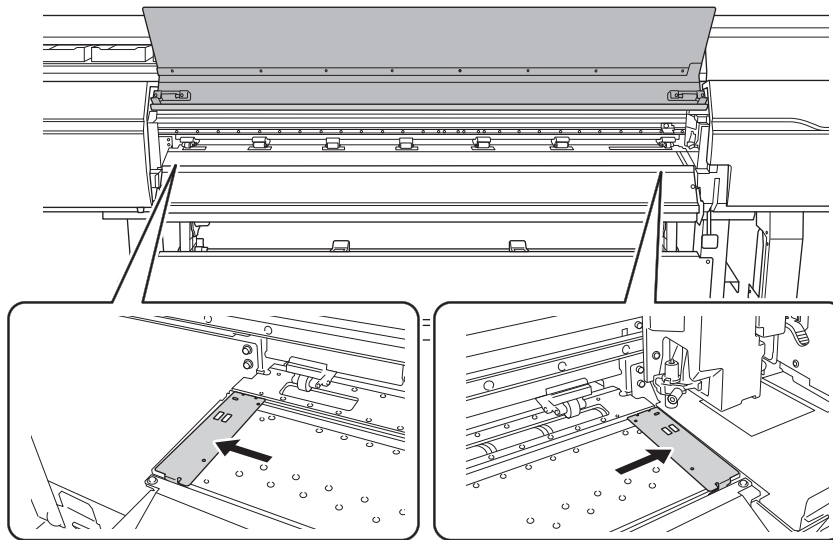

4. (Move to the rear of the printer.) Release the locking mechanisms of the media holders, and then draw them to the left and right ends respectively.

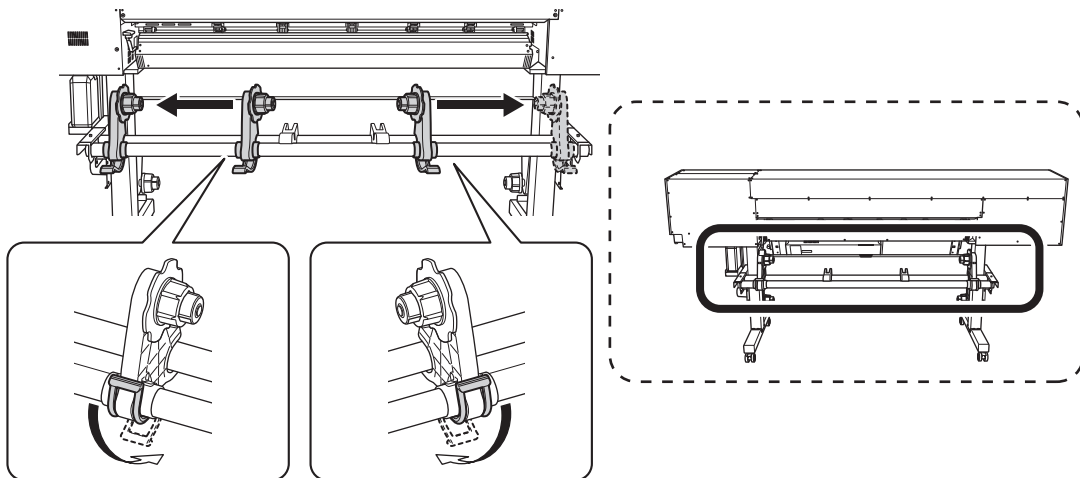

5. Pass the leading edge of the media between the pinch rollers (A) and the grit rollers (B).

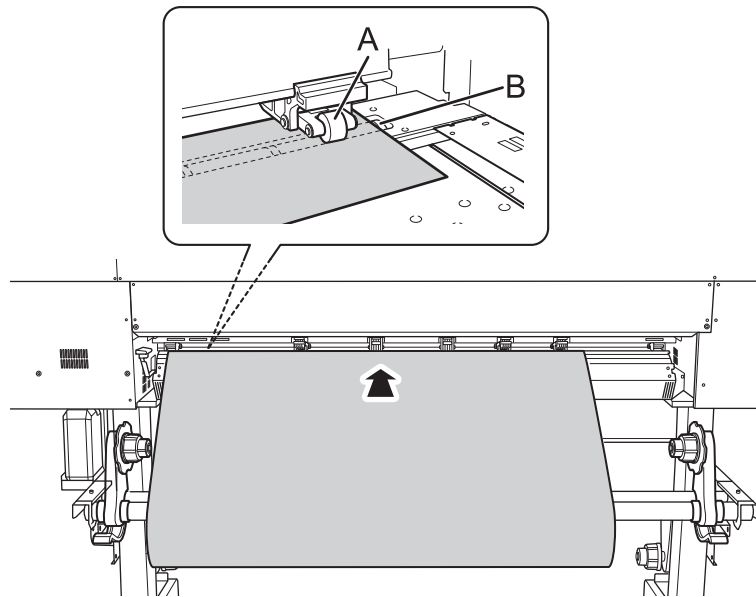

- 6. Lower the loading lever (rear).**
The media is held in place.

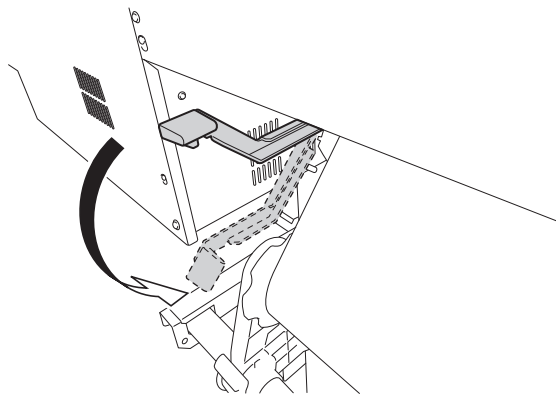

- 7. (Move to the front of the printer.) Gently hold down the media and raise the loading lever (front).**
The media is released.

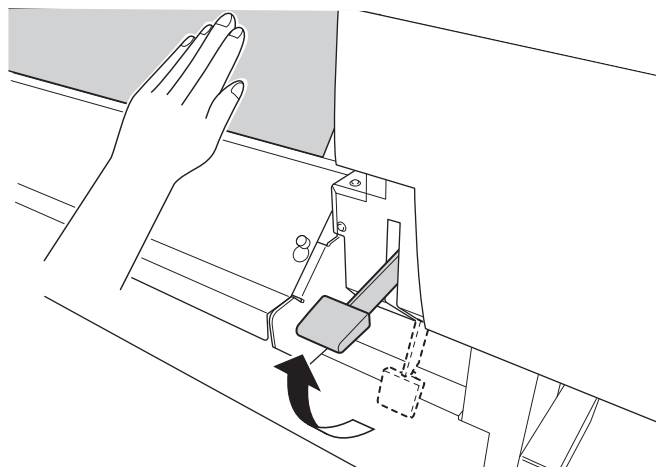

- 8. Make sure both edges of the media are above the grit rollers.**
Be sure to place the right edge of the media on the right-end grit roller.

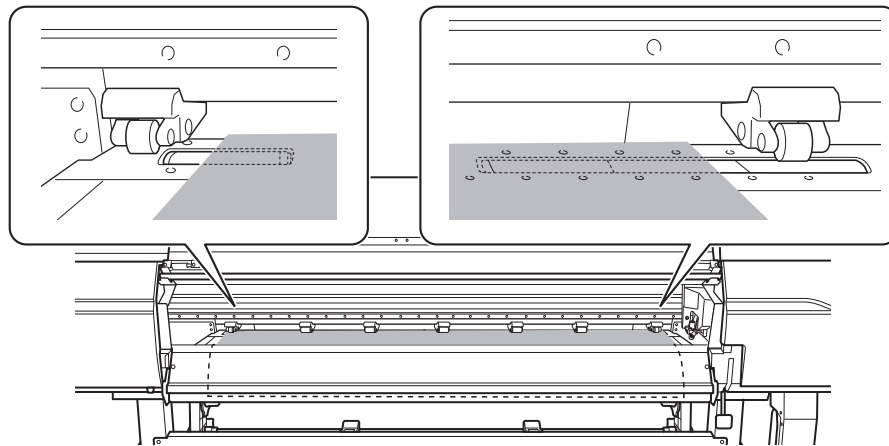

9. Move the left and right pinch rollers, placing them on both edges of the media. Position them approximately 10 mm (0.39 in.) from each edge of the media.

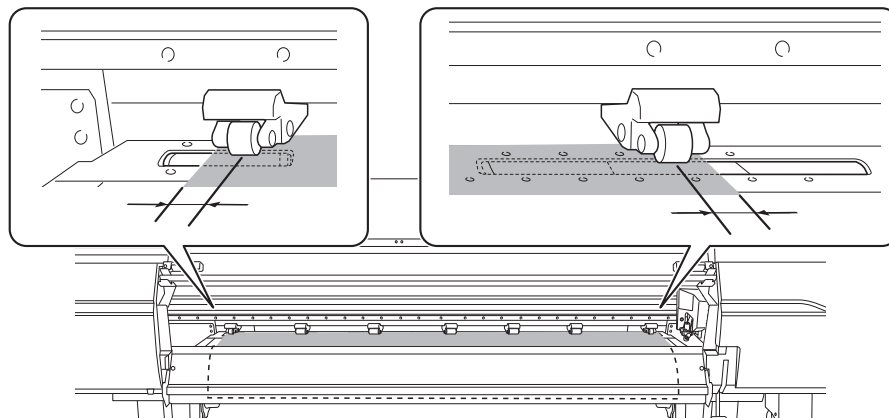

IMPORTANT

Be sure to use the left and right pinch rollers. The force with which the media is pinched varies between the middle pinch rollers and the left and right pinch rollers. Using the middle pinch rollers to pinch the media edges will lead to unstable media feeding.

MEMO

To smoothly move the pinch rollers, push down close to the rail.

10. Move the middle pinch rollers (B) over all the remaining grit rollers (A) covered by the media. There are grit patterns (C) wherever there are grit rollers.

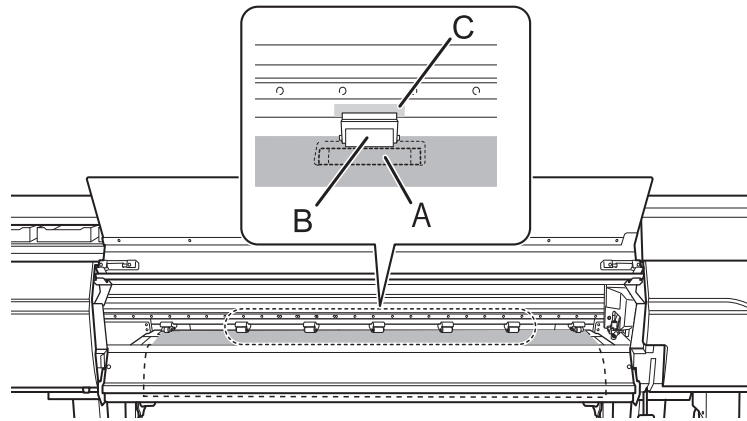
**IMPORTANT**

- Place the middle pinch rollers over all the grit patterns within the media width. If you have forgotten to place the middle pinch rollers, the media will be skewed during printing or will come loose, which will have an effect on the printing quality.
- The middle pinch roller will not lower onto the three grit rollers from the right end. Place the middle pinch roller on a grit roller other than these three.

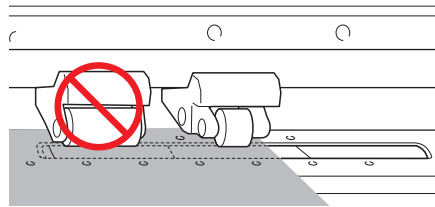

- There may be extra middle pinch rollers depending on the width of the media being used. Move the extra middle pinch rollers to positions where no grit patterns are present. Where no grit patterns are present, the middle pinch rollers will not come down.

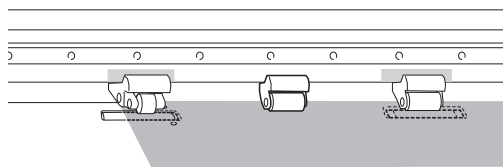
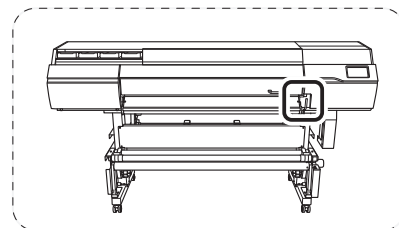
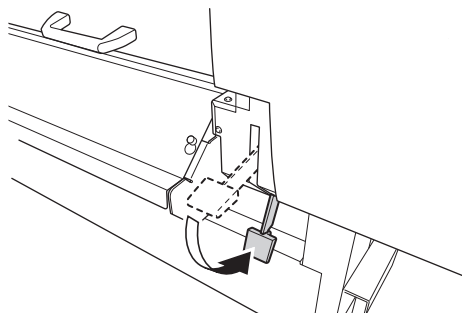
**11. Lower the loading lever (front).****IMPORTANT**

If you want to readjust the media position before securing it in place, redo the procedure from step 8.

12. Line up the edges of the media with the centers of the holes of the left and right media clamps.

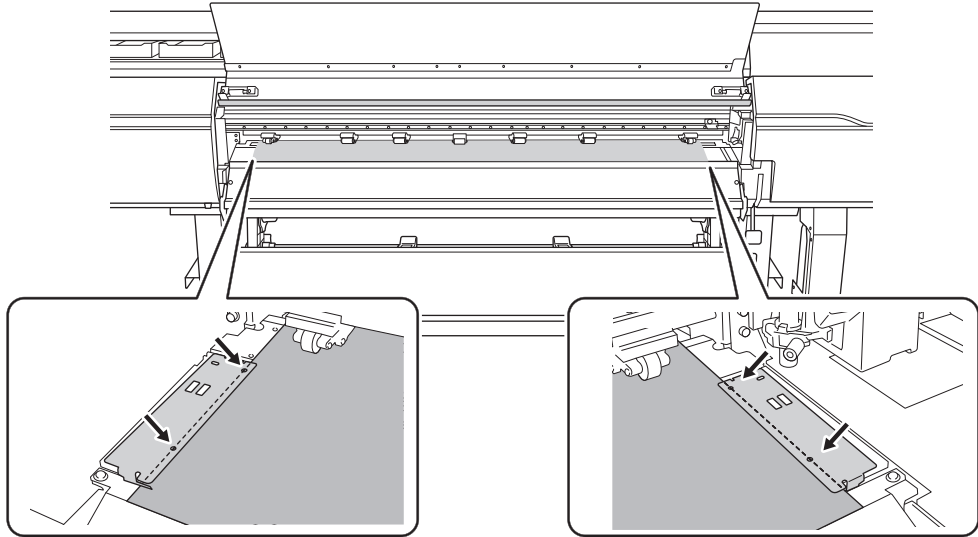

- 13. Close the front cover.

2. Register the media.

Procedure

1. Tap  [Setup].

2. Select [New].

3. Tap [Next].

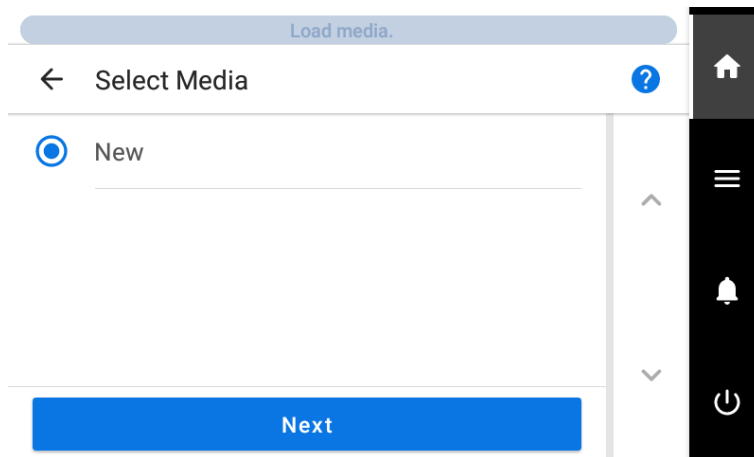

4. Enter a new media name and tap [OK].

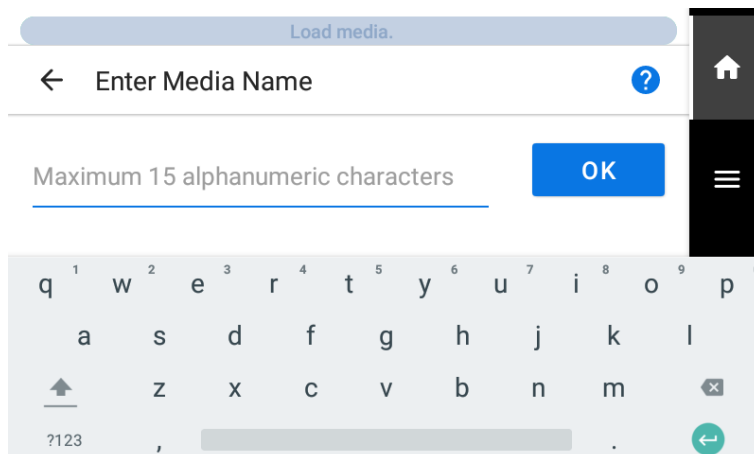

5. Tap [Next].

6. The [Setup Method] screen appears. Select whether to use the take-up unit.

7. Tap [Start Setup].

The cutting carriage moves and detects the width of the media and the positions of the media clamps. This operation is called initialization.

8. When [The media could not be detected automatically. Manually set the printing area.] appears, use the following procedure to configure the settings.

MEMO

This message may appear when media with high reflectance is set up.

- (1) Tap [OK].
- (2) Tap [Change].
The [Set the right edge of the printing area within the area specified by the pinch rollers.] screen appears.
- (3) Hold down  to move the center of the blade (A) approximately 2 mm (0.08 in.) to the inside (B) from the left edge of the right pinch roller.

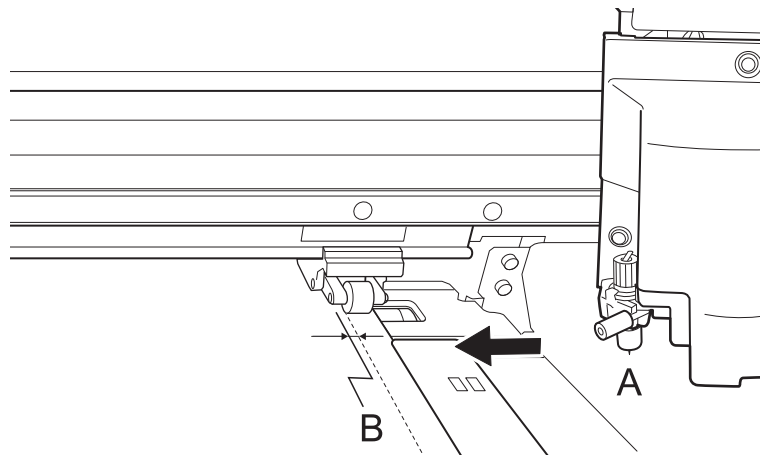

- (4) Tap [OK].
The [Set the left edge of the printing area within the area specified by the pinch rollers.] screen appears.
- (5) Hold down  to move the center of the blade (A) approximately 2 mm (0.08 in.) to the inside (B) from the right edge of the left pinch roller.

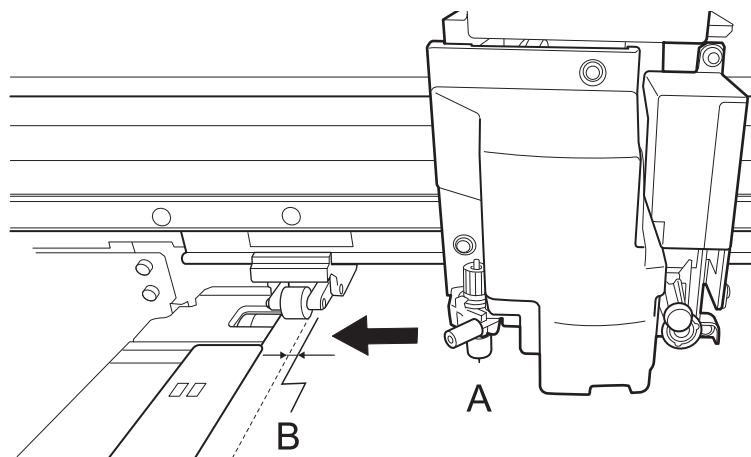



- (6) Tap [OK].
The set left and right positions are applied to the [Printing Area (Width)].
- (7) Tap [OK].

3. Configure settings to match the media.

To ensure the optimal output according to the media size and type, set the minimal amount of items. All items set here can be set individually as well.

Procedure

1. On the [Select Media Output Type] screen, select the output type and tap [Next].
 - [Print Only/Print & Cut]
Proceed to step 2.
 - [Cut Only]
Switch to the [Multi Sensor Adjustment] screen. When automatic adjustment is finished, tap [OK]. This completes the settings for [Cut Only].
2. On the [Heater Temperature] screen, adjust the [Print Heater] and [Dryer] temperatures.
 - If this is not necessary, tap [Next].
 - Follow the procedure below to make changes.
 - a. Tap  or  to set the [Print Heater] or [Dryer] temperature.
 - b. Tap [Next].
3. Use the [Print Head Height] screen to adjust the print head height.
 - If this is not necessary, tap [Next].
 - Follow the procedure below to make adjustments.
 - a. Tap [Change]
 - b. Open the front cover.
 - c. Move the height-adjustment lever to adjust the head height.
 - d. Close the front cover.
 - e. Tap [OK].
 - f. Tap [Next].
 For details on this work, refer to [Changing the Print Head Height\(P. 153\)](#).
4. On the [Nozzle Drop-out Test] screen, configure the [Printing Test] and [Output Start Location] settings.
 - If this is not necessary, tap [Next].
 - To perform a [Printing Test], tap [Printing Test]>[Execute]. For details on what to do after the printing test, refer to [Step 2: Normal Cleaning Method\(P. 118\)](#).
5. On the [Select Media Adjustment Method] screen, select the adjustment method.
Here, the media feed correction for reducing horizontal bands and the correction of the landing position of the ink will be adjusted.

MEMO

[Simple Correction (Auto)] is the recommended adjustment. You can determine the correction values with [Detailed Correction (Manual)].

- Follow the procedure below to make automatic adjustments.
 - a. Tap [Simple Correction (Auto)]>[Next].
 - b. Tap [Execute] on the [Batch Automatic Correction] screen.

On successful completion of automatic adjustment, the home screen appears. This completes the settings.

For more information, refer to [Automatically Making Required Adjustments\(P. 148\)](#).

- **Follow the procedure below to make manual adjustments.**
 - a. Tap [**Detailed Correction (Manual)**] > [**Next**].
 - b. Tap [**Execute**] on the [**Multi Sensor Adjustment**] screen.

Adjust the reading sensor to the optimal condition. If the adjustment failed, respond to the failure according to the information in [Correcting the Reading Sensor\(P. 193\)](#).
 - c. Tap [**Next**].
 - d. Perform a printing test on the [**Detailed Feed Correction (Manual)**] screen.

Set the correction value from the printing test result. For more information, refer to [Manual Adjustment: Reducing Horizontal Bands \(Feed Correction Function\)\(P. 149\)](#).
 - e. Tap [**Save and Proceed**].
 - f. Perform a printing test on the [**Detailed Media Gap Adjustment (Manual)**] screen.

Set the correction values from the printing test result. For more information, refer to [Manual Adjustment: Adjusting the Misalignment of the Ink Landing Position \(Media Gap Adjustment\)\(P. 151\)](#).
 - g. Tap [**Save and Exit**].

This completes the setup of the media.

Setup of Registered Media

⚠ CAUTION

Do not touch the dancer roller needlessly.

The media take-up unit and feeder may move suddenly, which may result in injury.

Setup of Roll Media

Load the roll media on the printer. When the loading is finished, [Output possible.] is displayed as the status. This work is referred to as "Setup of Media."

⚠ CAUTION

Load the roll media correctly.

Otherwise the media may fall and cause injury.

⚠ CAUTION

The roll media is approximately 35 kg (77.2 lb.) (30-inch model: 30 kg [66.1 lb.]).

To avoid injury, handle the roll media with care.

⚠ CAUTION

Never load media that weighs over 35 kg (77.2 lb.) (30-inch model: 30 kg [66.1 lb.]).

The machine may fail to withstand the weight and tip over or cause the media to fall.

📄 Install the media on the media holders.



The media holders of this machine are designed to be used with a paper tube (core) with an inner diameter of 2 inches or 3 inches.

⚠ WARNING

Handling roll media is an operation that must be performed by 2 persons or more, and care must be taken to prevent falls.

Attempting to lift heavy media in a manner that taxes your strength may cause physical injury. Also, if dropped, such items may cause injury.

Procedure

1. Tap  on the operation panel.
The sub power is switched on.
2. When using a take-up unit, use the following procedure to set it.
 - (1) Tap .
 - (2) Tap [Preferences]>[Take-up]>[Take-up Direction].

- (3) Select [Backward] or [Forward].
- (4) Tap [Save].
- (5) Tap  to go back to the original screen.

3. Open the front cover.

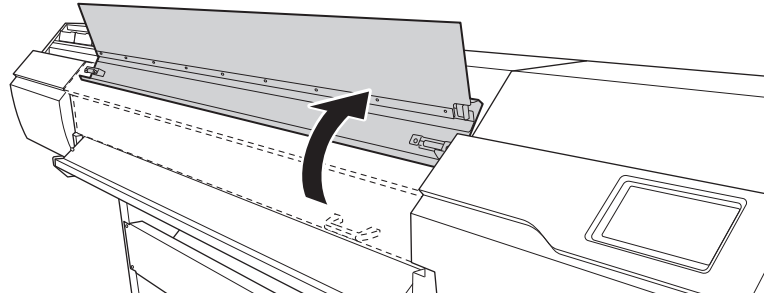

4. Move the media clamps to the outside of the grit rollers on the left and right edges respectively.

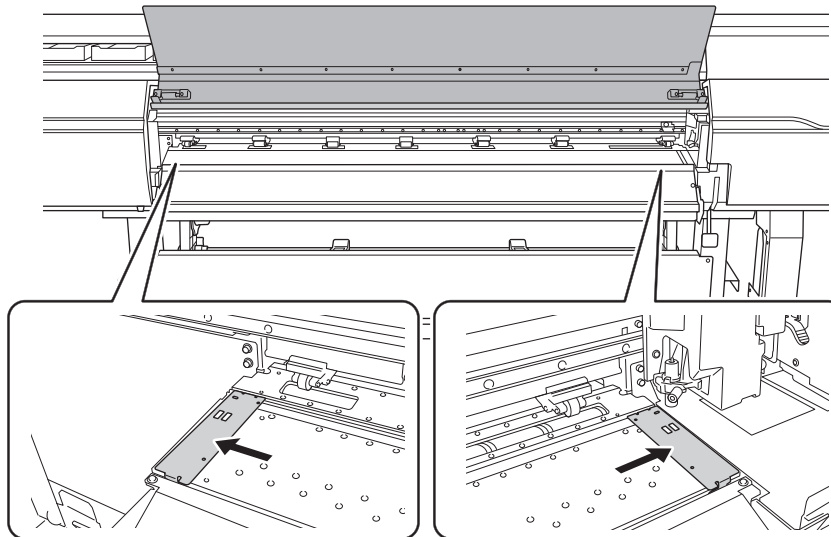

5. (Move to the rear of the printer.) Release the locking mechanisms of the media holders, and then draw them to the left and right ends respectively.

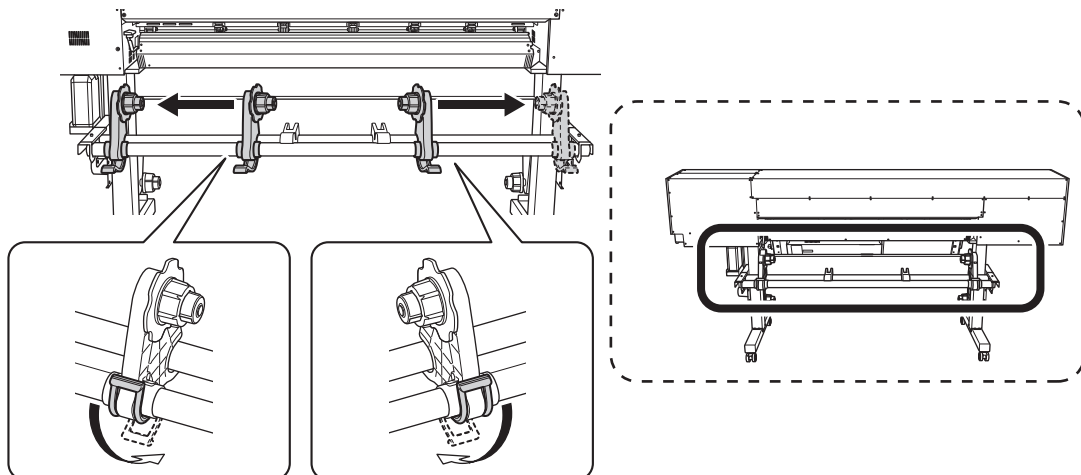

6. Place the media on the machine.

IMPORTANT

Do not leave media on the media stays or the pipes for a long period of time. The media may become deformed. Exercise caution.

- **Media with an outer diameter of 220 mm (8.66 in.) or less**

Place the media stays at positions that are 1/4 the length of the media from each end of the media, and then load the media.

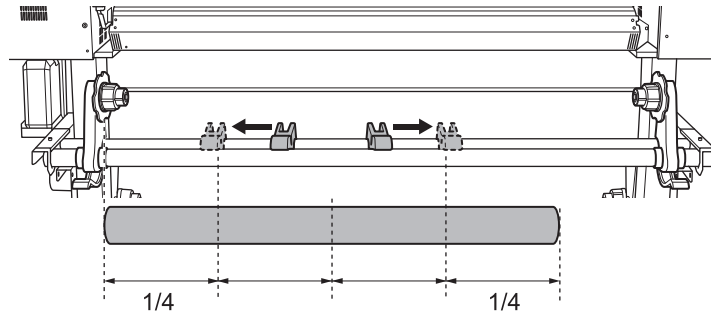

- **Media with an outer diameter exceeding 220 mm (8.67 in.)**

a. Rotate the media stays to draw them to the media holders.

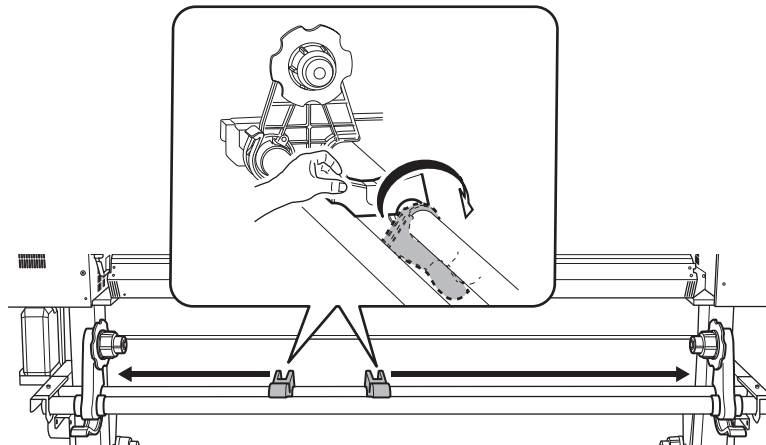

b. Place the media directly between the two pipes.

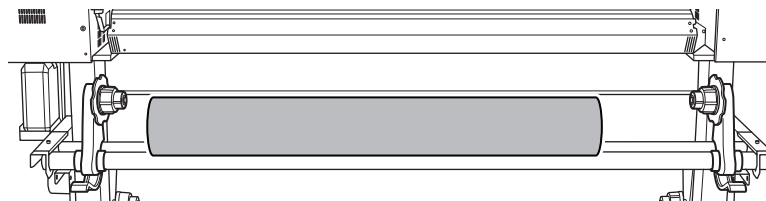

7. Fit the paper tube (core) of the media onto the end cap of the left media holder.

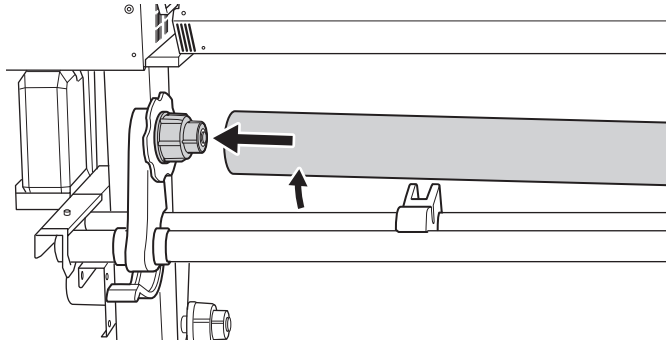

8. Move the right media holder to fit its end cap onto the paper tube (core) of the media.
Fit the paper tube onto the media holders securely to prevent the media from moving easily.

IMPORTANT

Do not secure the media holders in place just yet.

In the following procedure, you will adjust the positions of the media holders before securing them in place. Do not secure them in place just yet.

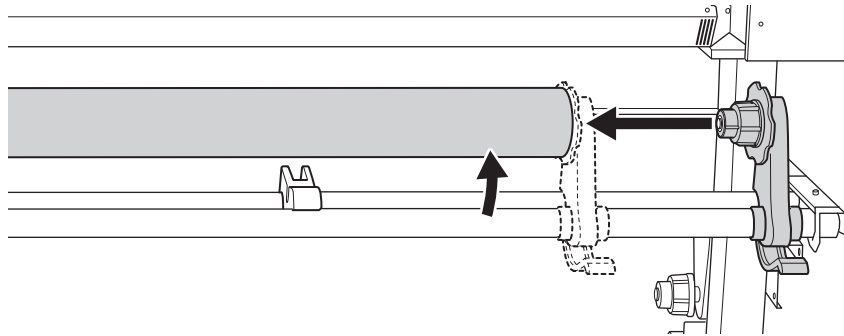

A: Determine the positions of the media.

This section describes how to use the suction fan to prevent media skewing. When using transparent media, whose edges cannot be detected, and when [Preferences]>[Media Edge Detection] is set to [Disable], the suction fan does not activate, so media cannot be loaded with this procedure. In these cases, refer to 2. B: Determine the positions of the media ([Media Edge Detection]: [Disable]).(P. 39).

By default, [Skewing Correction Support at Setup] is set to [Enable].

Procedure

1. Determine the left and right positions of the media with the grit patterns used as the reference.

Note the following points when determining the positions.

- Hold the media holders from the outside and move them.
- Ensure that the left edge of the media is positioned so that it is within the range of the grit pattern of the left edge.
- Ensure that the right edge of the media is positioned so that it is within the range of one of the grit patterns.

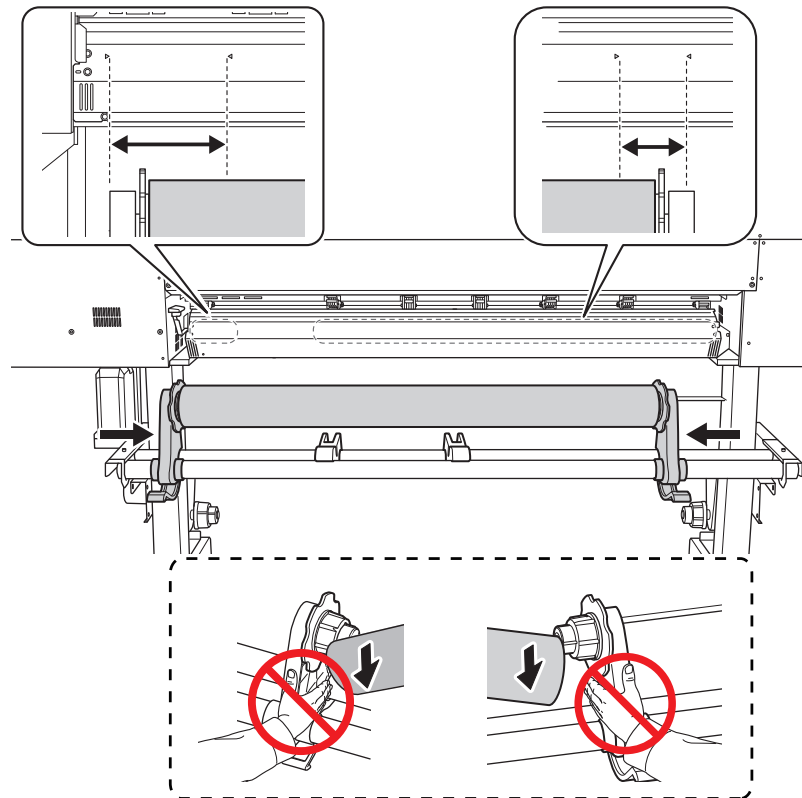

CAUTION

Do not hold places other than those instructed. Do not move the media by holding it directly.

Otherwise the media may fall off the media holder and cause injury.

IMPORTANT

Firmly decide the left and right side positions of the media at this point.

After this procedure is completed, if the left and right side positions do not fit the proper positions when securing the media with pinch rollers, you will have to go back to this step to redo this procedure. If you just

hold the media to readjust its position forcibly, the media will be skewed during printing, which will have an adverse effect on the printing results.

2. Secure the media holders.

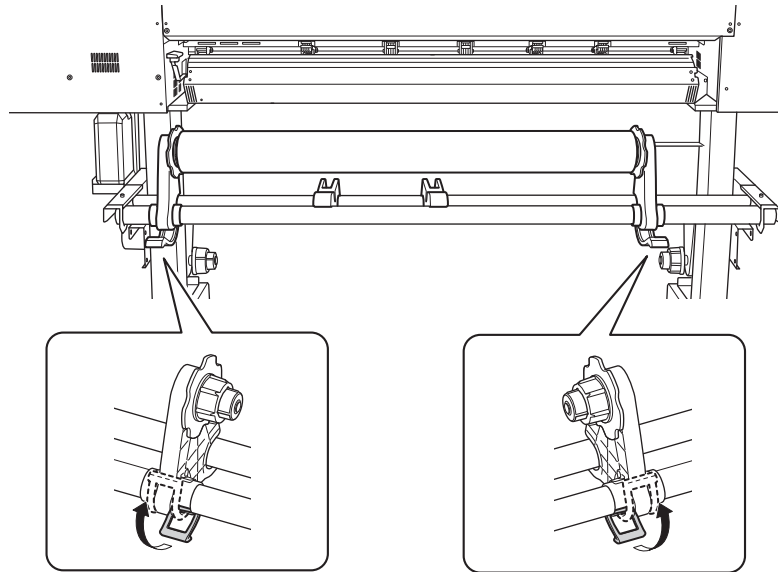

3. Use the following procedure to load the media.

Doing so will prevent media skewing.

- (1) Pass the leading edge of the media between the pinch rollers (A) and the grit rollers (B).

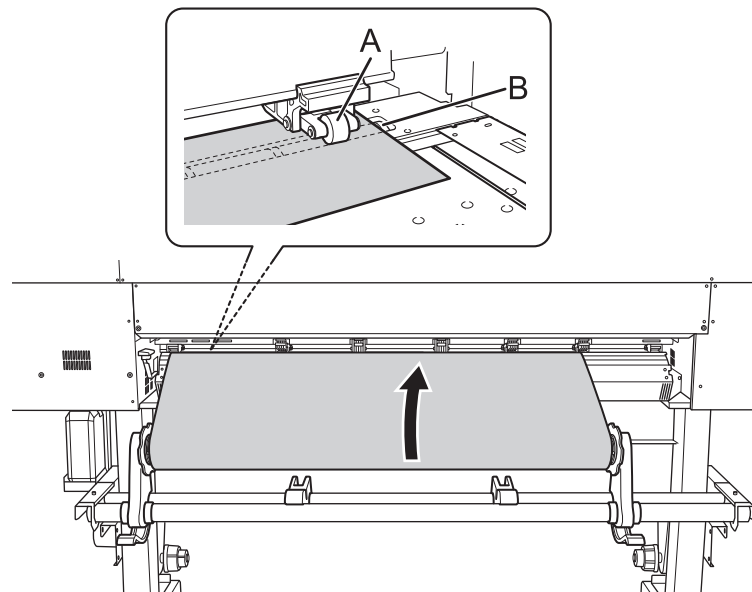

- (2) Feed the media until you hear a beep, and then additionally feed approximately 20 cm (7.87 in.) of the media.

You will hear a beep. Approximately 5 seconds later, you will hear two beeps, and then the suction fan will activate. While this fan is operating, the position of the media will be maintained even if you remove your hands from it.

- (3) Hold the media holder flange, turning it in the take-up direction to eliminate the slack in the media.

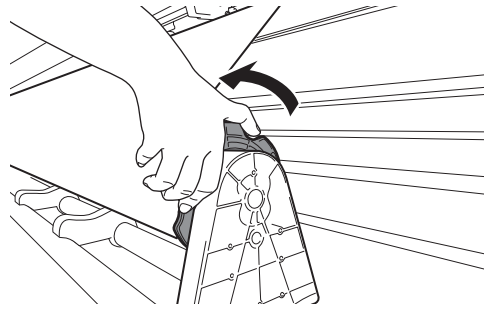

(4) Once the media is taut, additionally take up approximately 10 cm (3.94 in.) of media.

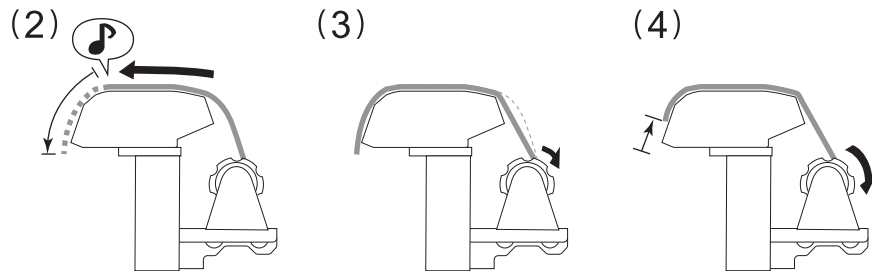

MEMO

If you take up too much media, you will hear two short beeps and the suction fan will stop. Take up the media, and then redo the procedure from step (1).

4. (Move to the front of the printer.) Make sure both edges of the media are above the grit rollers. Be sure to place the right edge of the media on the right-end grit roller.

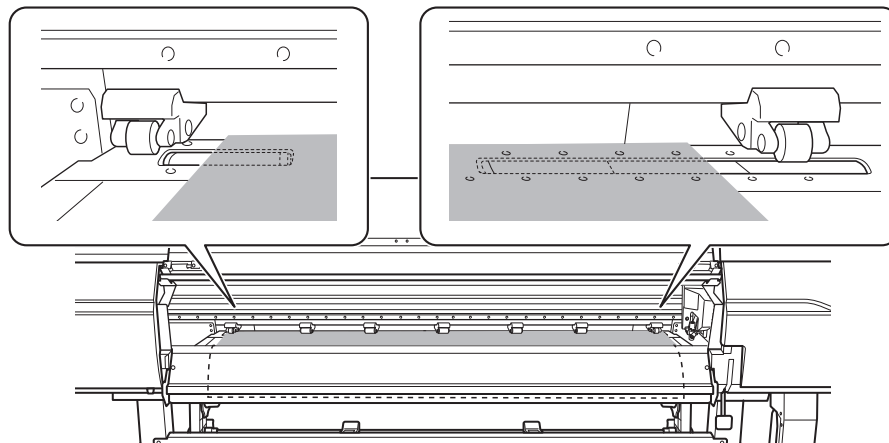

5. Move the left and right pinch rollers, placing them on both edges of the media. Position them approximately 10 mm (0.39 in.) from each edge of the media.

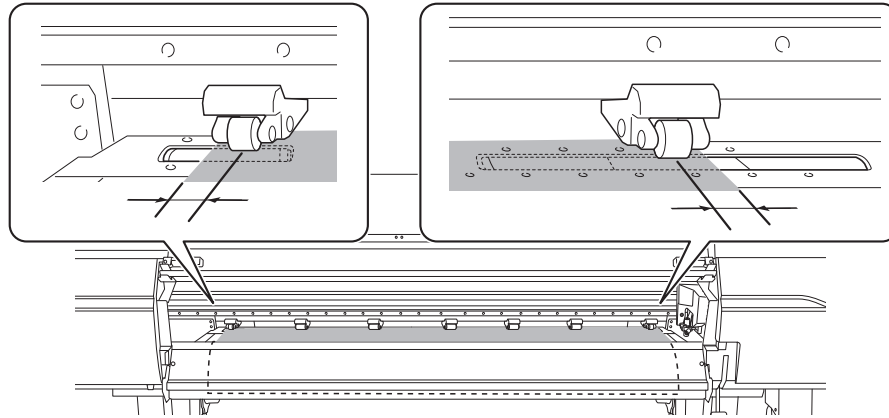

IMPORTANT

- Be sure to use the left and right pinch rollers. The force with which the media is pinched varies between the middle pinch rollers and the left and right pinch rollers. Using the middle pinch rollers to pinch the media edges will lead to unstable media feeding.
- If you want to readjust the media position, return to the back of the printer, release the media holders, and then redo the procedure from step 1. If you just stand at the front of the printer and hold the media to readjust its position forcibly, the media will be skewed during printing or will come loose, which will affect the printing quality.

MEMO

To smoothly move the pinch rollers, push down close to the rail.

6. Move the middle pinch rollers (B) over all the remaining grit rollers (A) covered by the media. There are grit patterns (C) wherever there are grit rollers.

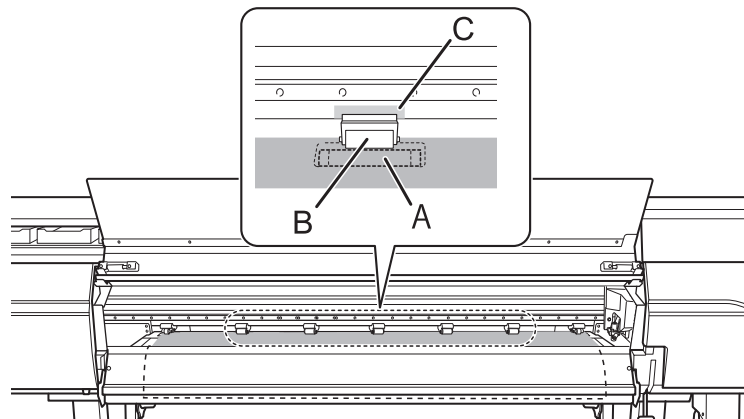

IMPORTANT

- Place the middle pinch rollers over all the grit patterns within the media width. If you have forgotten to place the middle pinch rollers, the media will be skewed during printing or will come loose, which will have an effect on the printing quality.
- The middle pinch roller will not lower onto the three grit rollers from the right end. Place the middle pinch roller on a grit roller other than these three.

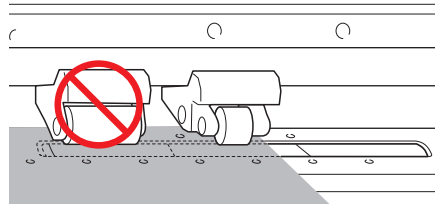

- There may be extra middle pinch rollers depending on the width of the media being used. Move the extra middle pinch rollers to positions where no grit patterns are present. Where no grit patterns are present, the middle pinch rollers will not come down.

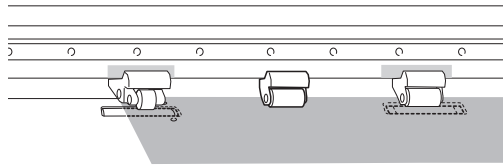

7. Lower the loading lever (front).

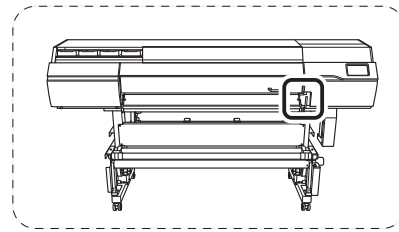
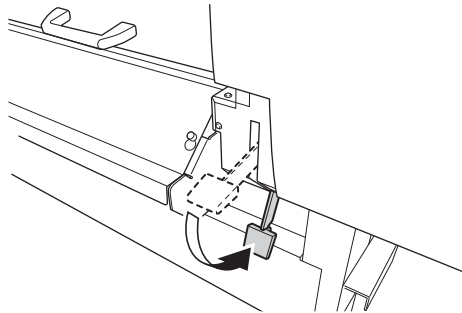

IMPORTANT

If you want to readjust the media position, return to the back of the printer, release the media holders, and then redo the procedure from step 1. If you just stand at the front of the printer and hold the media to readjust its position forcibly, the media will be skewed during printing or will come loose, which will affect the printing quality.

8. Line up the edges of the media with the centers of the holes of the left and right media clamps.

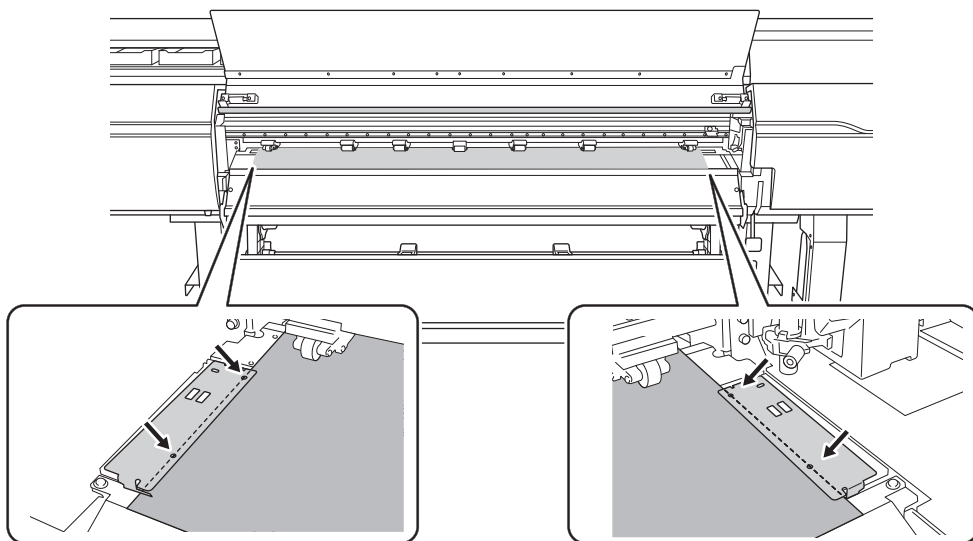

9. Close the front cover.

2. B: Determine the positions of the media ([Media Edge Detection]: [Disable]).

This section describes how to determine the positions of the media without using the suction fan. Refer to this information when using transparent media, whose edges cannot be detected, and when [Preferences]>[Media Edge Detection] is set to [Disable].

Procedure

1. Determine the left and right positions of the media with the grit patterns used as the reference.

Note the following points when determining the positions.

- Hold the media holders from the outside and move them.
- Ensure that the left edge of the media is positioned so that it is within the range of the grit pattern of the left edge.
- Ensure that the right edge of the media is positioned so that it is within the range of one of the grit patterns.

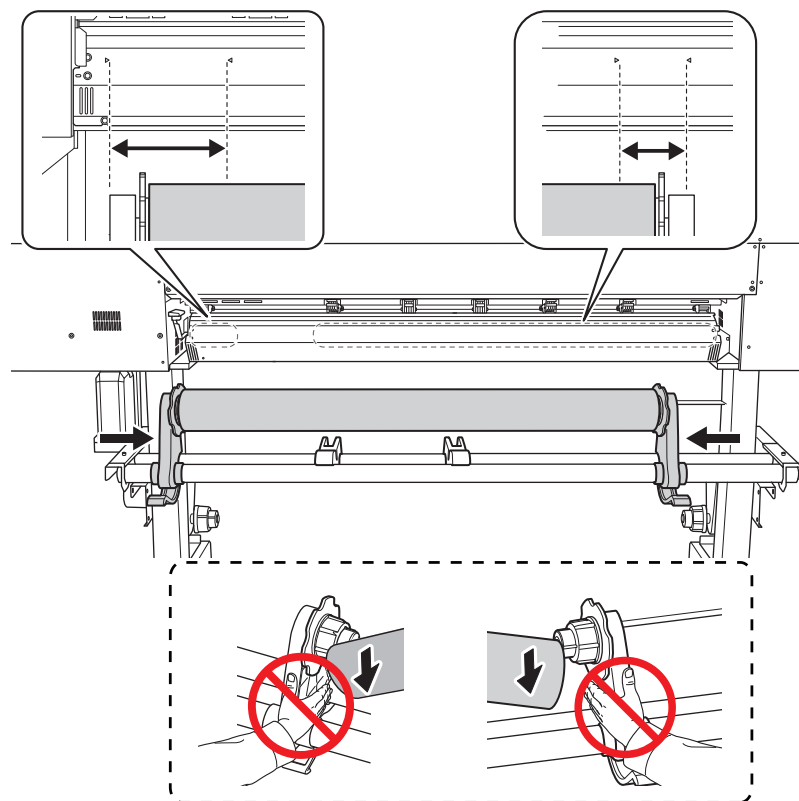

⚠ CAUTION

Do not hold places other than those instructed. Do not move the media by holding it directly.

Otherwise the media may fall off the media holder and cause injury.

IMPORTANT

Firmly decide the left and right side positions of the media at this point.

After this procedure is completed, if the left and right side positions do not fit the proper positions when securing the media with pinch rollers, you will have to go back to this step to redo this procedure. If you just hold the media to readjust its position forcibly, the media will be skewed during printing, which will have an adverse effect on the printing results.

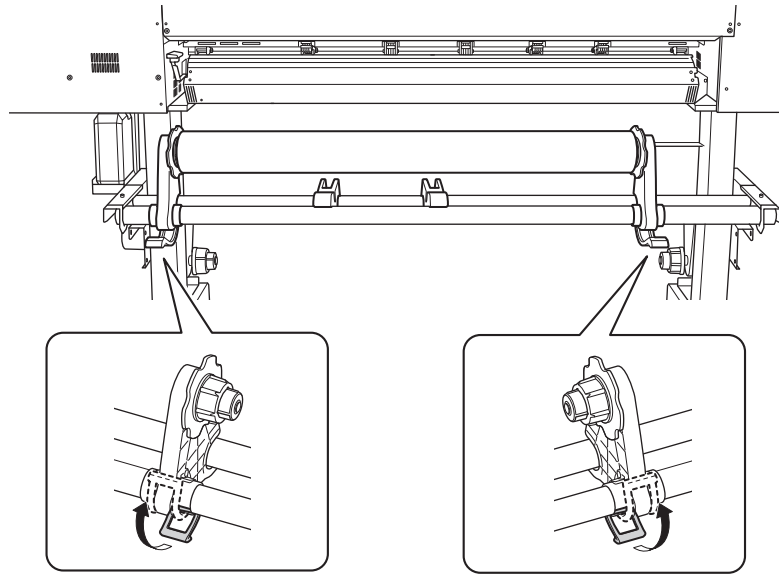
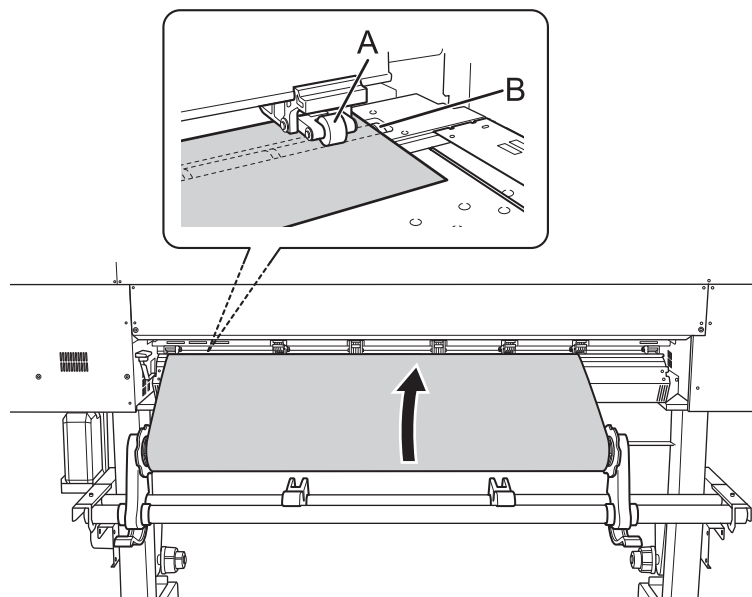
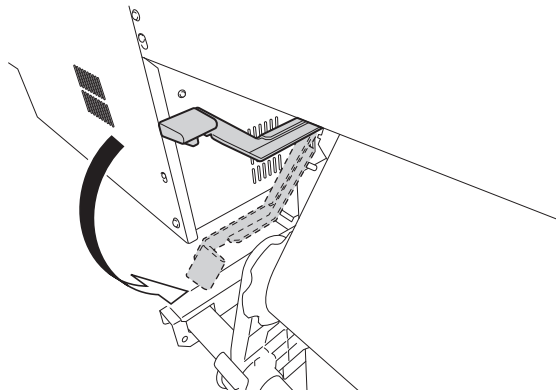
2. Secure the media holders.**3. Pass the leading edge of the media between the pinch rollers (A) and the grit rollers (B).****4. Lower the loading lever (rear).
The media is held in place.**

5. (Move to the front of the printer.) Gently hold down the media and raise the loading lever (front). The media is released.

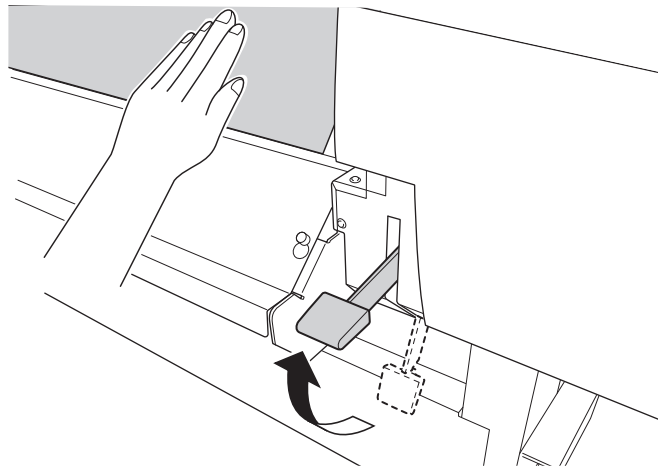

6. Pull out the media over the apron.

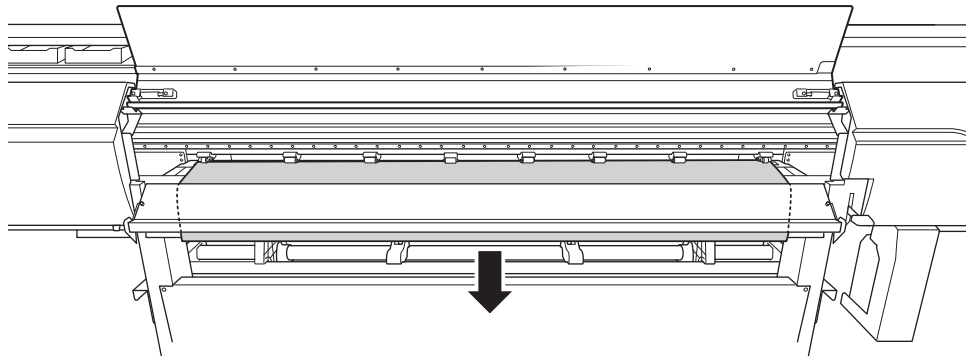

7. Make sure both edges of the media are above the grit rollers.
Be sure to place the right edge of the media on the right-end grit roller.

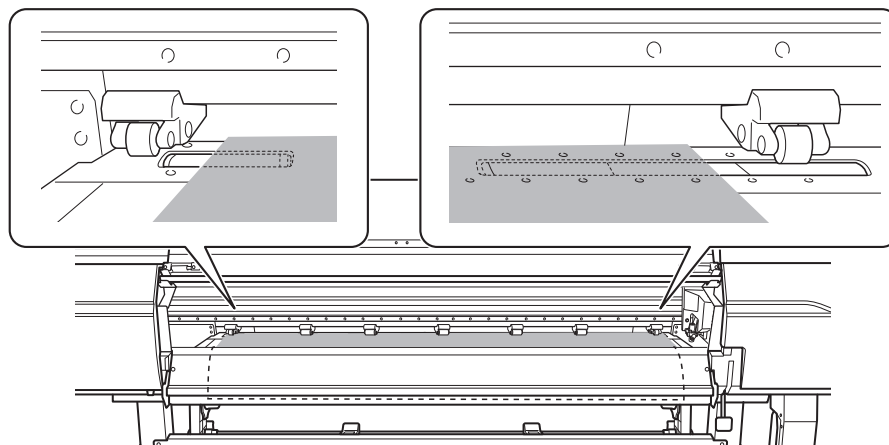

8. Move the left and right pinch rollers, placing them on both edges of the media.
Position them approximately 10 mm (0.39 in.) from each edge of the media.

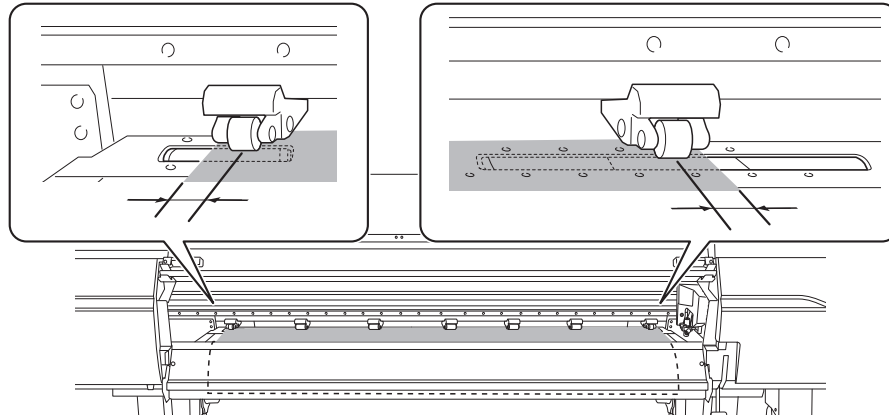
**IMPORTANT**

- Be sure to use the left and right pinch rollers. The force with which the media is pinched varies between the middle pinch rollers and the left and right pinch rollers. Using the middle pinch rollers to pinch the media edges will lead to unstable media feeding.
- If you want to readjust the media position, return to the back of the printer, release the media holders, and then redo the procedure from step 1. If you just stand at the front of the printer and hold the media to readjust its position forcibly, the media will be skewed during printing or will come loose, which will affect the printing quality.

MEMO

To smoothly move the pinch rollers, push down close to the rail.

- 9. Move the middle pinch rollers (B) over all the remaining grit rollers (A) covered by the media.**
There are grit patterns (C) wherever there are grit rollers.

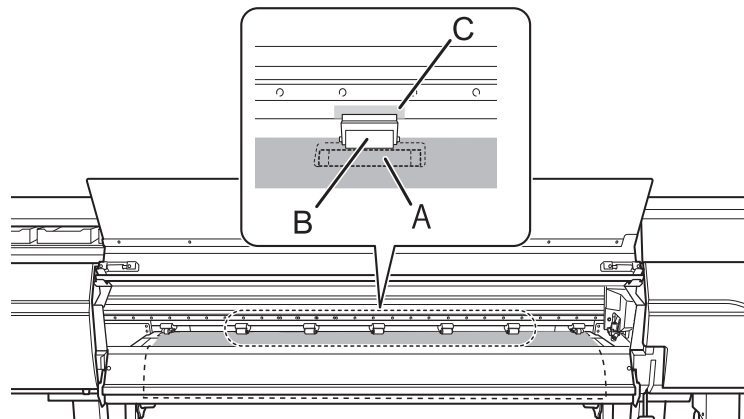
**IMPORTANT**

- Place the middle pinch rollers over all the grit patterns within the media width. If you have forgotten to place the middle pinch rollers, the media will be skewed during printing or will come loose, which will have an effect on the printing quality.
- The middle pinch roller will not lower onto the three grit rollers from the right end. Place the middle pinch roller on a grit roller other than these three.

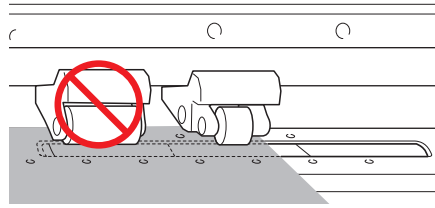

- There may be extra middle pinch rollers depending on the width of the media being used. Move the extra middle pinch rollers to positions where no grit patterns are present. Where no grit patterns are present, the middle pinch rollers will not come down.

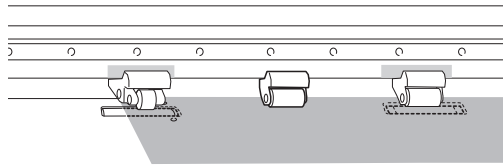

10. Hold the media at the center and pull it out, being sure to keep it straight and all areas of the media to be taut.

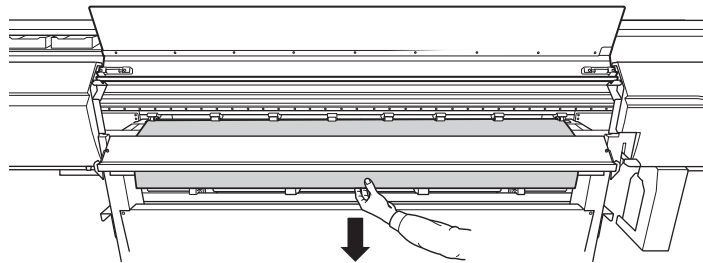

Good

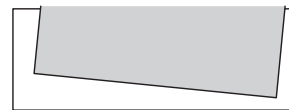

Not good

11. Lower the loading lever (front).

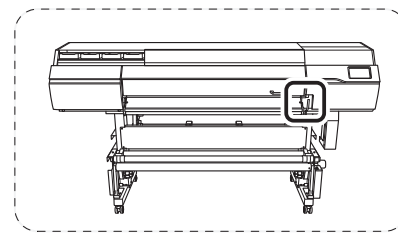
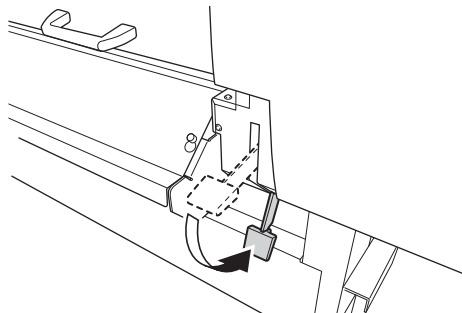

12. Line up the edges of the media with the centers of the holes of the left and right media clamps.

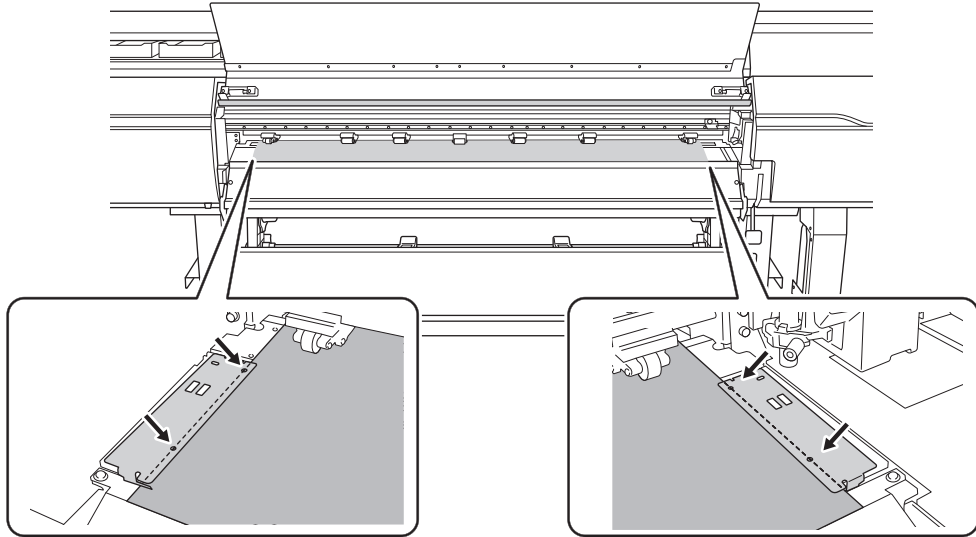

13. Close the front cover.

3. Select the media.

Procedure





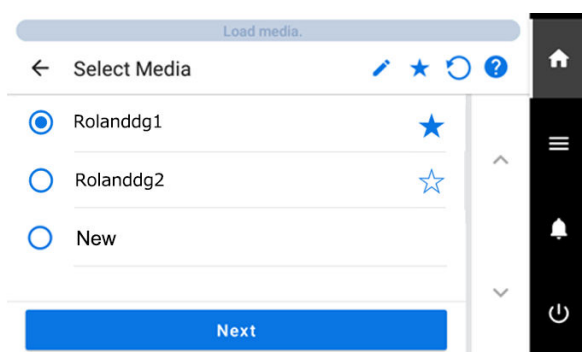



1. Tap  [Setup].

The registered media is displayed in a list.



2. Select the media name to use.

MEMO

- Tapping  makes it possible to search the registered media by keyword.
To reset the entered keyword, tap .
- Tapping  to the right of the media name will change the symbol to , and the media will be registered to Favorites.
Tap the favorites filter () at the top of the operation panel to turn the filter on () and show only favorited media.
Tap  to turn the Favorites filter off.
- Tap  to turn the Favorites filter off () and reset all keywords.
- Keyword searching and the Favorites filter can be used at the same time.

3. Tap [Next].

4. The [Setup Method] screen appears. Select whether to use the take-up unit.

5. Tap [Start Setup].

The cutting carriage moves and detects the width of the media and the positions of the media clamps. This operation is called initialization.

6. When [Printing Area (Width)] screen appears, use the following procedure to configure the settings.

MEMO

The media selected in step 2 is media whose printing area was set manually when registered as new media. The printing area must be set manually each time, so the [Printing Area (Width)] screen appears.

- (1) Tap [Change].

The [Set the right edge of the printing area within the area specified by the pinch rollers.] screen appears.

- (2) Hold down  to move the center of the blade (A) approximately 2 mm (0.08 in.) to the inside (B) from the left edge of the right pinch roller.

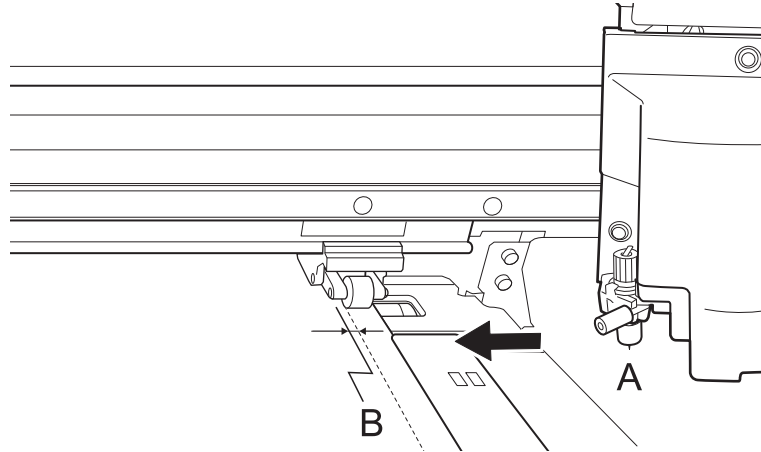

- (3) Tap [OK].

The [Set the left edge of the printing area within the area specified by the pinch rollers.] screen appears.

- (4) Hold down  to move the center of the blade (A) approximately 2 mm (0.08 in.) to the inside (B) from the right edge of the left pinch roller.

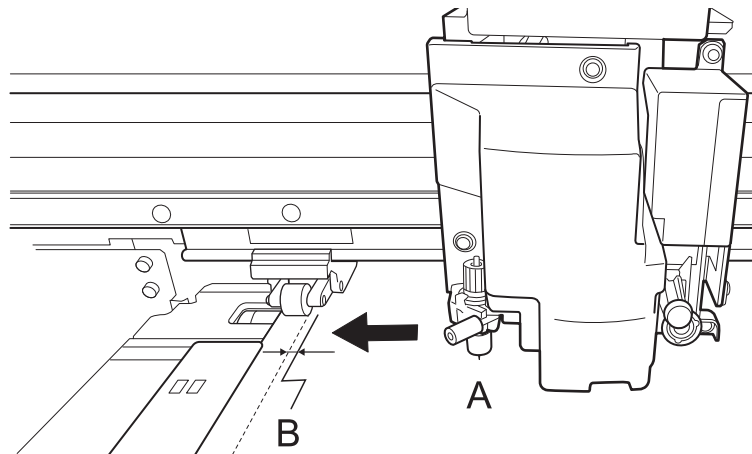

- (5) Tap [OK].

The set left and right positions are applied to the [Printing Area (Width)].

- (6) Tap [OK].

4. Load the media in the take-up unit.

If you will not use the take-up unit, setup is complete.

Procedure

1. Lower the dancer roller toward the rear.

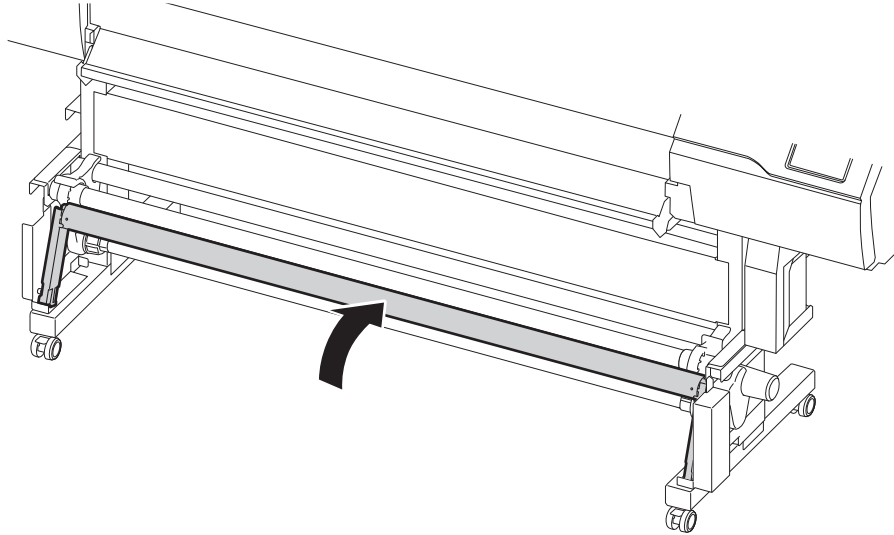

2. Follow the procedure below to load a paper tube on the media holders of the take-up unit.
Prepare a paper tube wider than the media that has been set up.

IMPORTANT

Paper tubes are consumable items.

Watch the condition of the paper tube and replace at an appropriate time so that the media can be taken up in good working order.

- (1) Release the media holders to enable their movement.

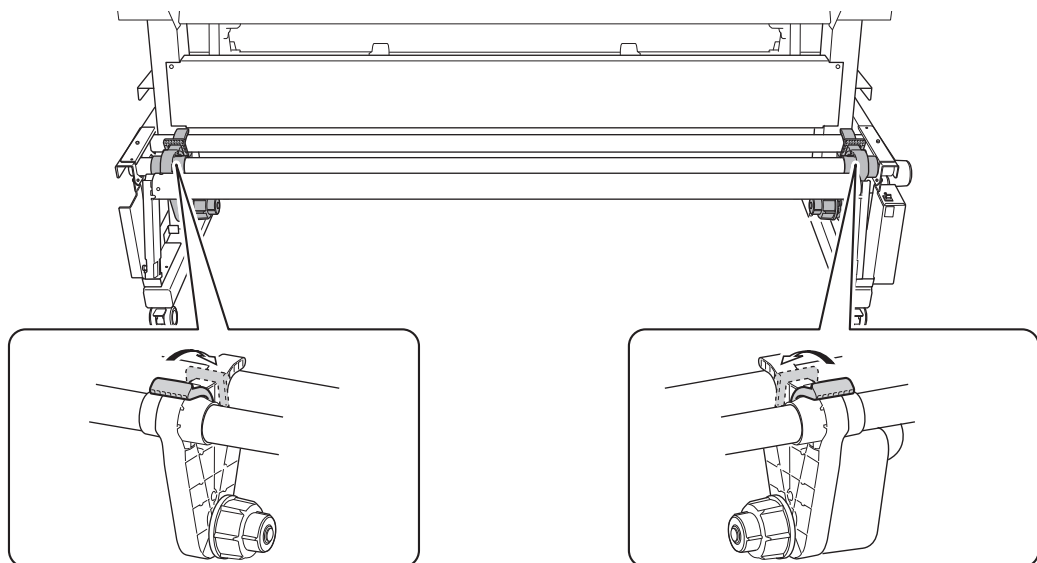

- (2) Fit the paper tube onto the right end cap.
Fit the paper tube securely right to the end of the end cap.
- (3) Push the left media holder into the paper tube.

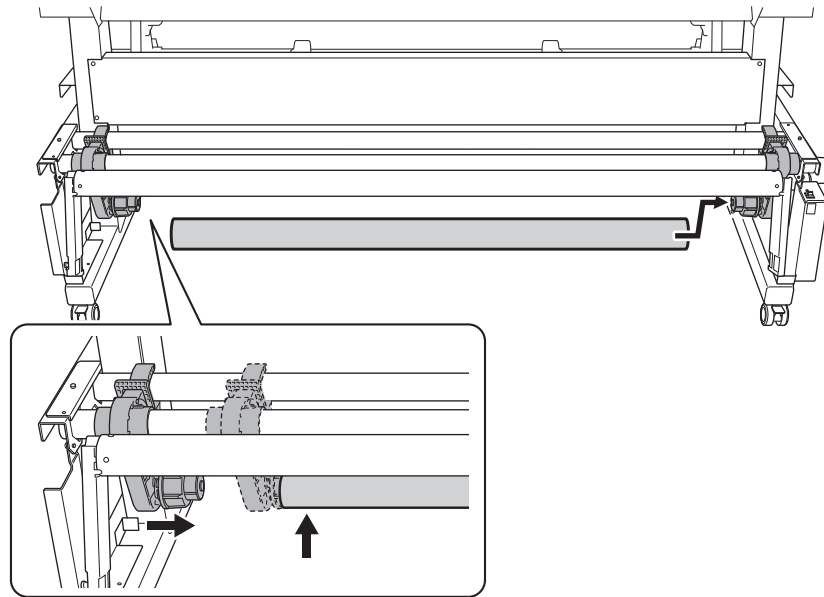

3. Hold down  on the operation panel to feed out the media until the tip of the media reaches the paper tube.

Media is fed out 10 mm (0.39 in.) each time you hold down this button. Holding down the button lets you feed out paper continuously.

Good

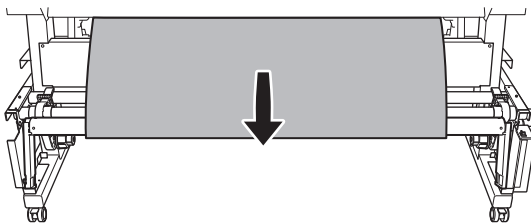

Not Good

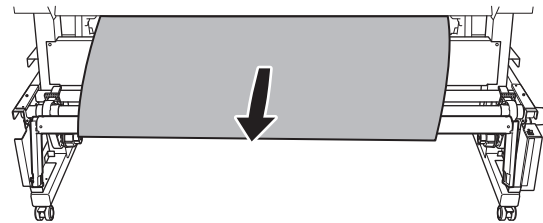

MEMO

Feed out the media until it can wrap around at least 1/4 of the paper tube.

When using the FORWARD setting	When using the BACKWARD setting

4. Follow the procedure below to adjust the positions of the media holders.
- (1) Move both media holders so that it is possible to see the paper tube from the right edge of the media.
 - Hold the media holders from the outside and move them.
 - Adjust the positions so media is taken up in the center of the paper tube.

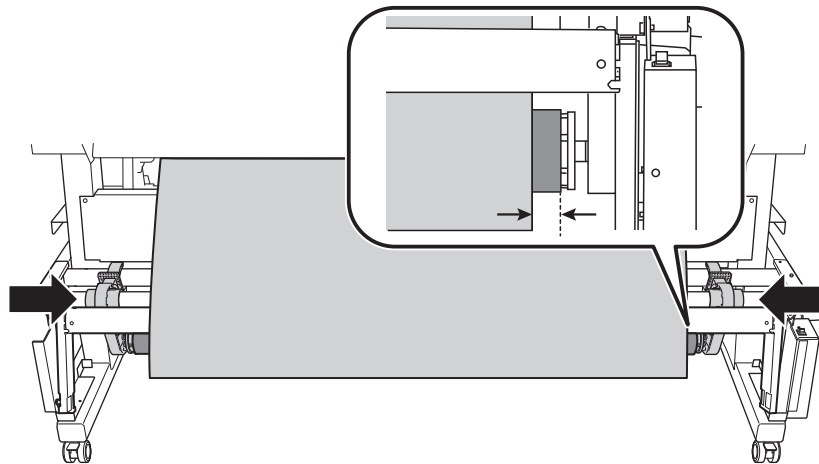

(2) Secure the left and right media holders.

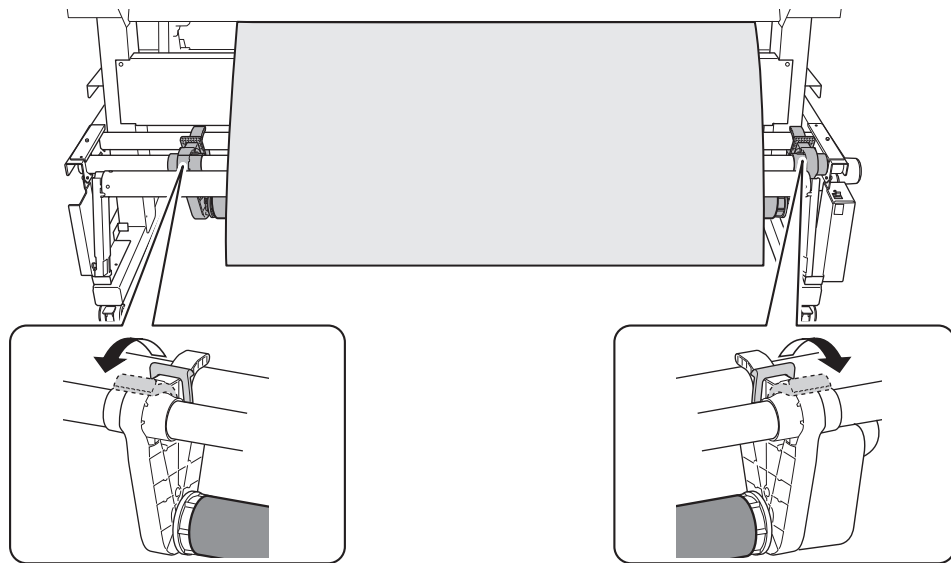

5. Follow the procedure below to secure the media on the paper tube.

Secure the media in the [Take-up Direction] set in step 2 of [Install the media on the media holders.](#)(P. 67).

- (1) While pulling the media so that it does not sag, secure the center of the media on the paper tube with adhesive tape.
- (2) While pulling the media from the center toward the outer edges, secure the left and right edges of the media on the paper tube with adhesive tape.

- When using the FORWARD setting

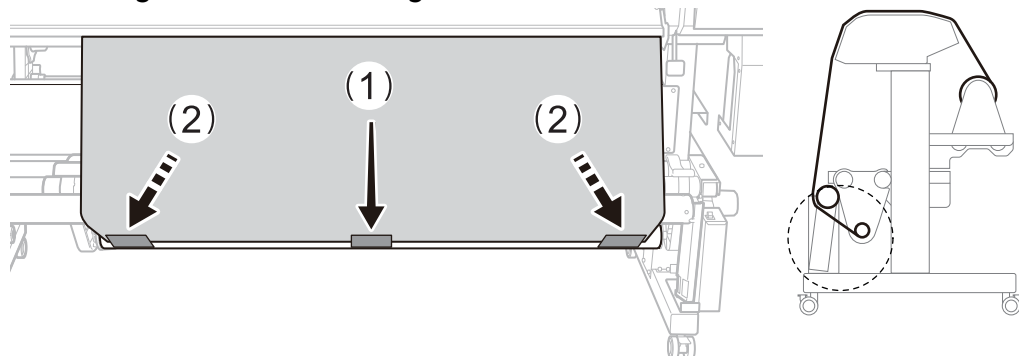

- When using the BACKWARD setting

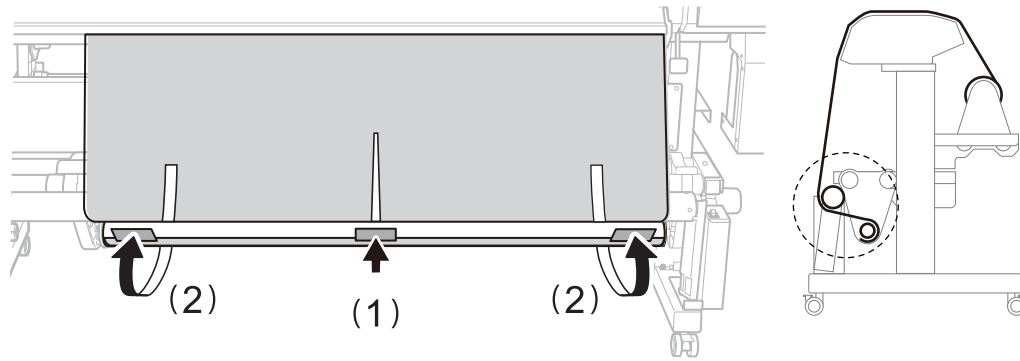

6. Tap [OK].
A small amount of the media is fed out.
7. Lower the dancer roller toward the front.

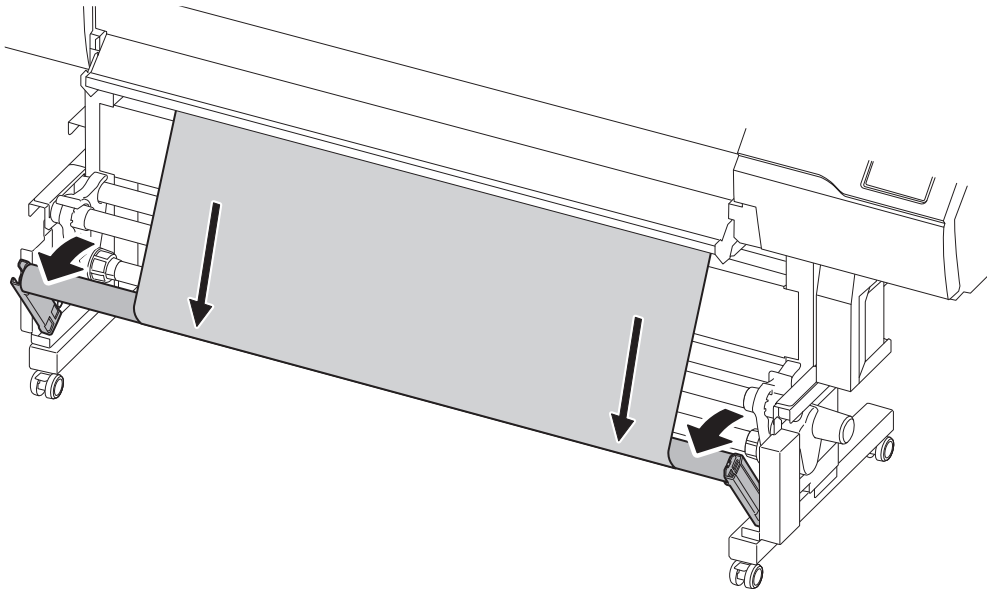

8. Tap [OK].

IMPORTANT

When printing and cutting or just cutting, rewind the media from the take-up device to slacken the media. If sufficient media is not wound on the paper tube immediately after setup, this operation may not be performed well, lowering the cutting quality and preventing continued take-up. When performing cutting immediately after attaching the media to the paper tube, first feed enough media to carry out take-up a few times and set the base point.

Setup of Sheet Media

Load the sheet media on the printer. When the loading is finished, [Output possible.] is displayed as the status. This work is referred to as "Setup of Media."

1. A: Determine the positions of the media.

When using transparent media, whose edges cannot be detected, and when [Preferences]>[Media Edge Detection] is set to [Disable], the suction fan does not activate, so media cannot be loaded with this procedure. In these cases, refer to [1. B: Determine the positions of the media \(\[Media Edge Detection\]: \[Disable\]\)](#). (P. 58).

By default, [Skewing Correction Support at Setup] is set to [Enable].

Procedure

1. Tap  on the operation panel.
The sub power is switched on.
2. Open the front cover.
3. Move the media clamps to the outside of the grit rollers on the left and right edges respectively.

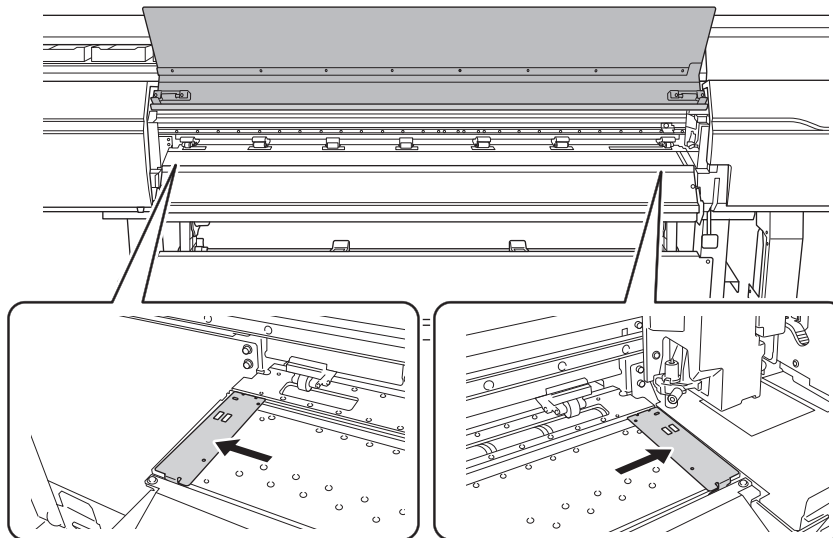

4. (Move to the rear of the printer.) Release the locking mechanisms of the media holders, and then draw them to the left and right ends respectively.

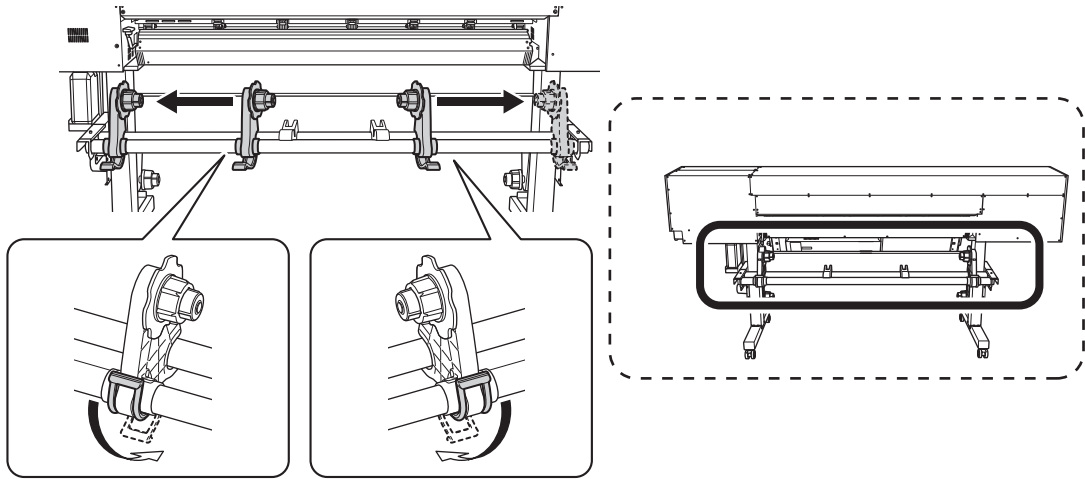

- 5.** From the rear of the printer, pass the leading edge of the media between the pinch rollers (A) and the grit rollers (B).

You will hear a beep. Approximately 5 seconds later, you will hear two beeps, and then the suction fan will activate. While this fan is operating, the media will not move backward even if you remove your hands from it.

When loading the media from the front of the printer, feed the leading edge of the media (the side where printing will start) over the platen, and then pull the media to the front to activate the suction fan.

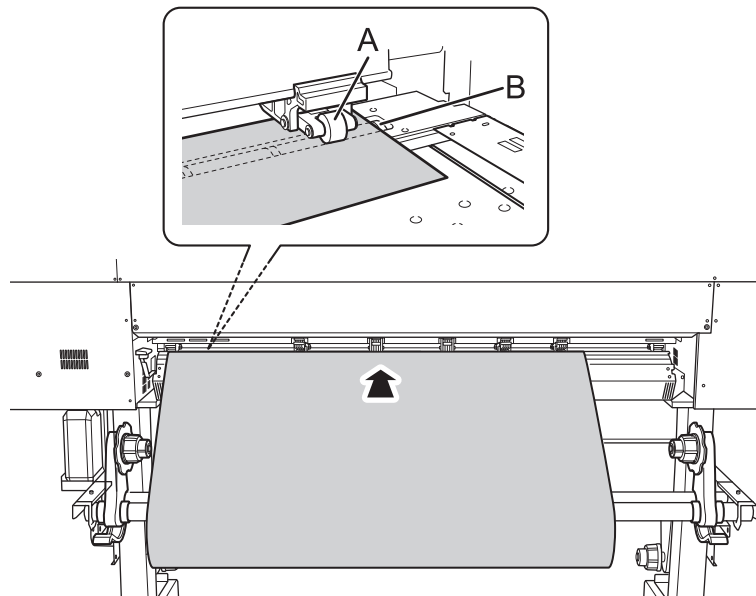

- 6.** (Move to the front of the printer.) Make sure both edges of the media are above the grit rollers. Be sure to place the right edge of the media on the right-end grit roller.

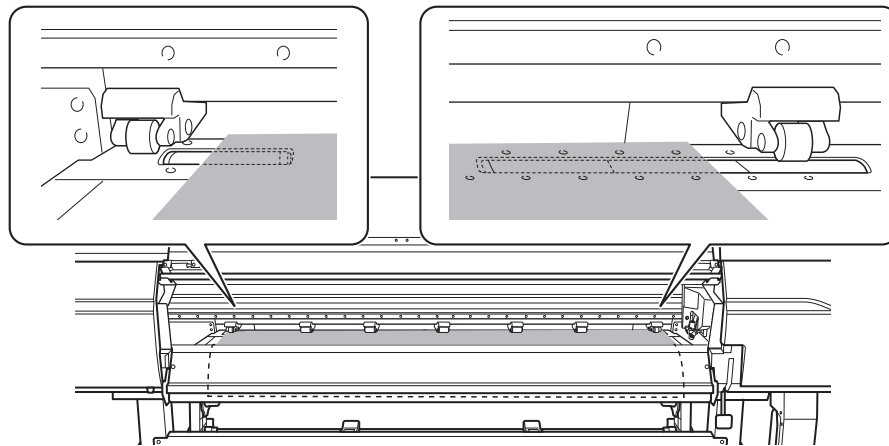

7. Move the left and right pinch rollers, placing them on both edges of the media. Position them approximately 10 mm (0.39 in.) from each edge of the media.

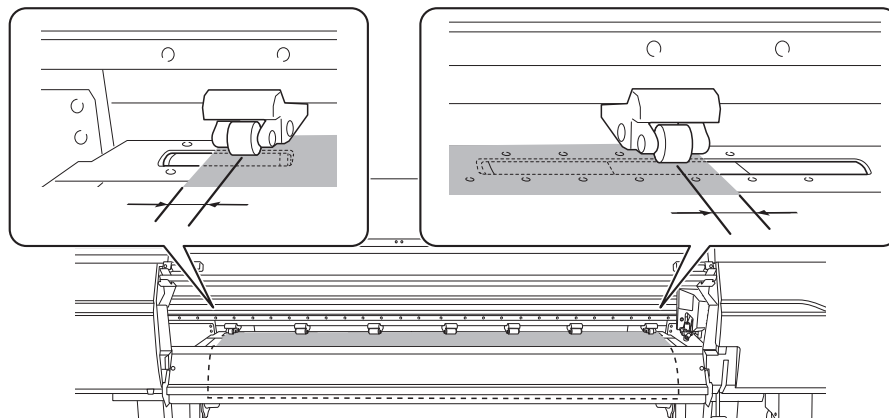

IMPORTANT

- Be sure to use the left and right pinch rollers. The force with which the media is pinched varies between the middle pinch rollers and the left and right pinch rollers. Using the middle pinch rollers to pinch the media edges will lead to unstable media feeding.
- If you want to readjust the media position before securing it in place, redo the procedure from step 5.

MEMO

To smoothly move the pinch rollers, push down close to the rail.

8. Move the middle pinch rollers (B) over all the remaining grit rollers (A) covered by the media. There are grit patterns (C) wherever there are grit rollers.

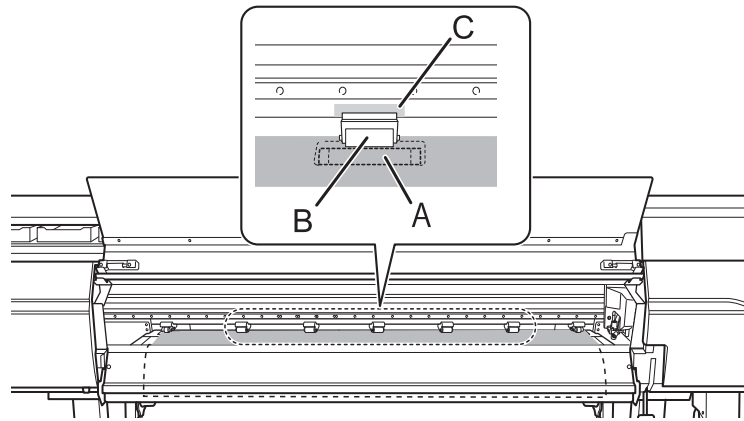
**IMPORTANT**

- Place the middle pinch rollers over all the grit patterns within the media width. If you have forgotten to place the middle pinch rollers, the media will be skewed during printing or will come loose, which will have an effect on the printing quality.
- The middle pinch roller will not lower onto the three grit rollers from the right end. Place the middle pinch roller on a grit roller other than these three.

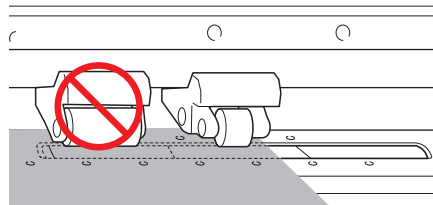

- There may be extra middle pinch rollers depending on the width of the media being used. Move the extra middle pinch rollers to positions where no grit patterns are present. Where no grit patterns are present, the middle pinch rollers will not come down.

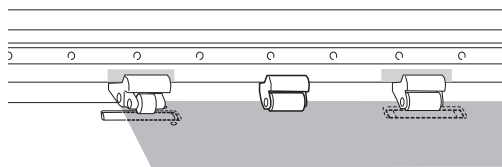
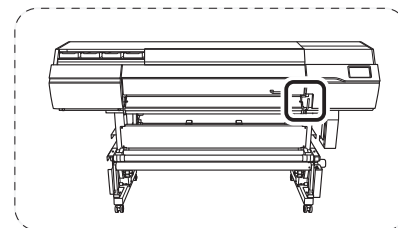
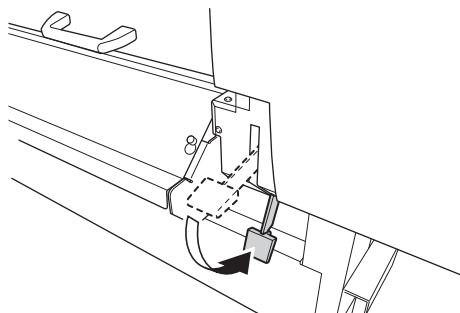
**9. Lower the loading lever (front).****IMPORTANT**

If you want to readjust the media position before securing it in place, redo the procedure from step 5.

10. Line up the edges of the media with the centers of the holes of the left and right media clamps.

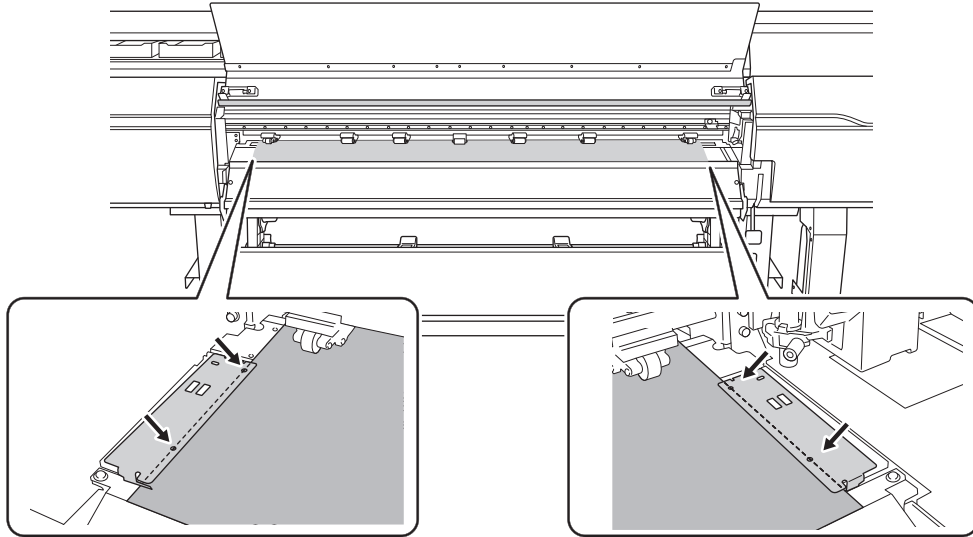

- 11. Close the front cover.

1. B: Determine the positions of the media ([Media Edge Detection]: [Disable]).

Use the following procedure to determine the positions of the media when using transparent media, whose edges cannot be detected, and when [Preferences]>[Media Edge Detection] is set to [Disable].

Procedure

1. Tap  on the operation panel.

The sub power is switched on.

2. Open the front cover.

3. Move the media clamps to the outside of the grit rollers on the left and right edges respectively.

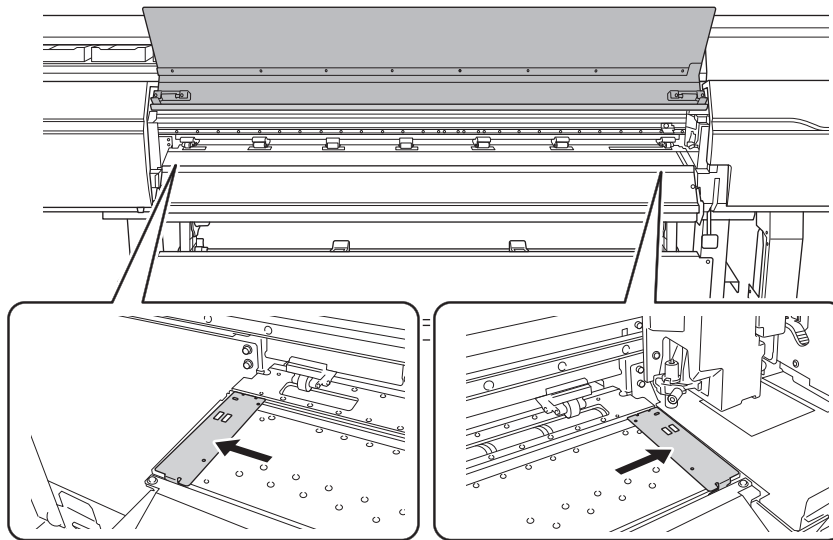

4. (Move to the rear of the printer.) Release the locking mechanisms of the media holders, and then draw them to the left and right ends respectively.

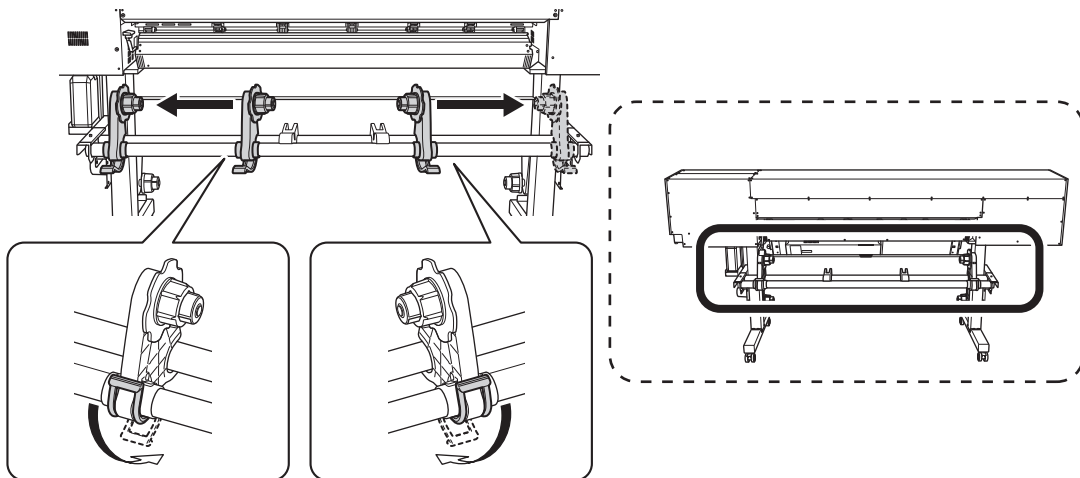

5. Pass the leading edge of the media between the pinch rollers (A) and the grit rollers (B).

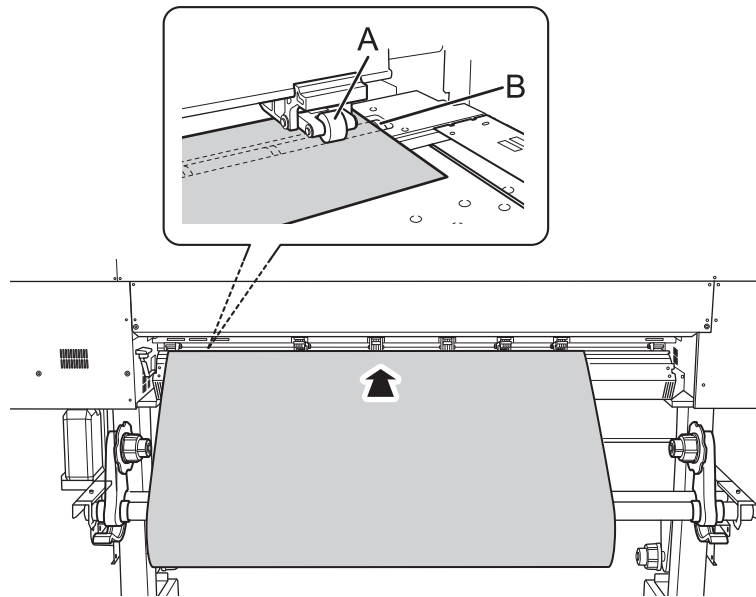

6. Lower the loading lever (rear).
The media is held in place.

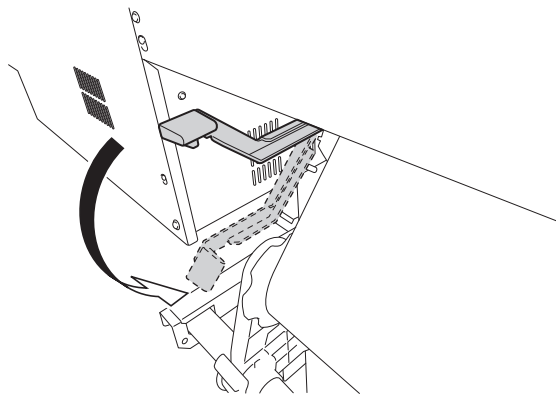

7. (Move to the front of the printer.) Gently hold down the media and raise the loading lever (front).
The media is released.

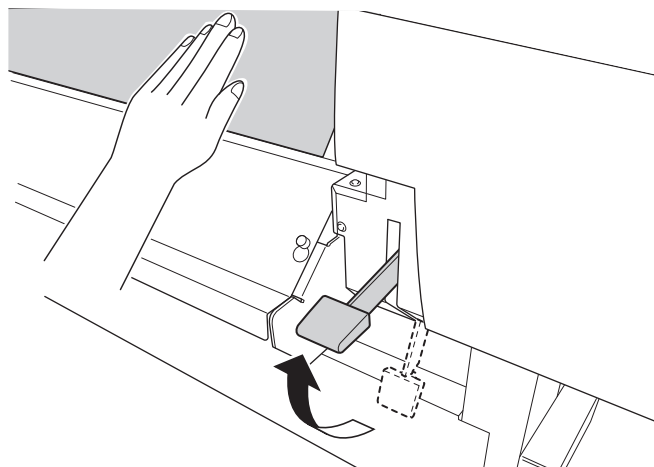

8. Make sure both edges of the media are above the grit rollers.
Be sure to place the right edge of the media on the right-end grit roller.

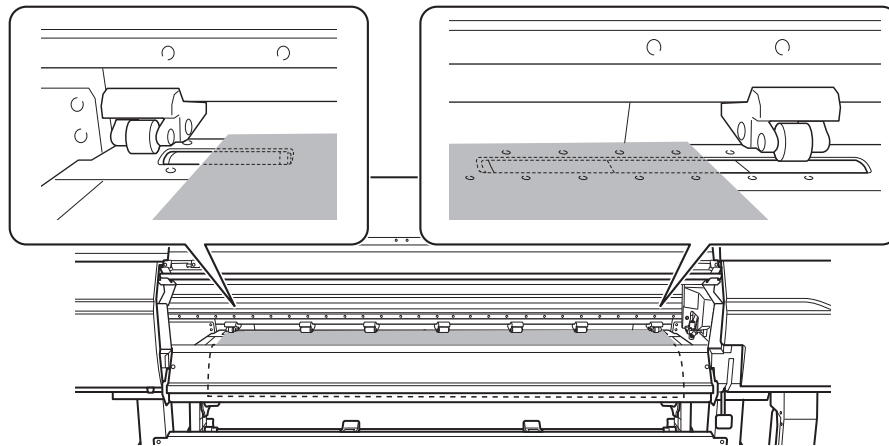

- 9. Move the left and right pinch rollers, placing them on both edges of the media.**
Position them approximately 10 mm (0.39 in.) from each edge of the media.

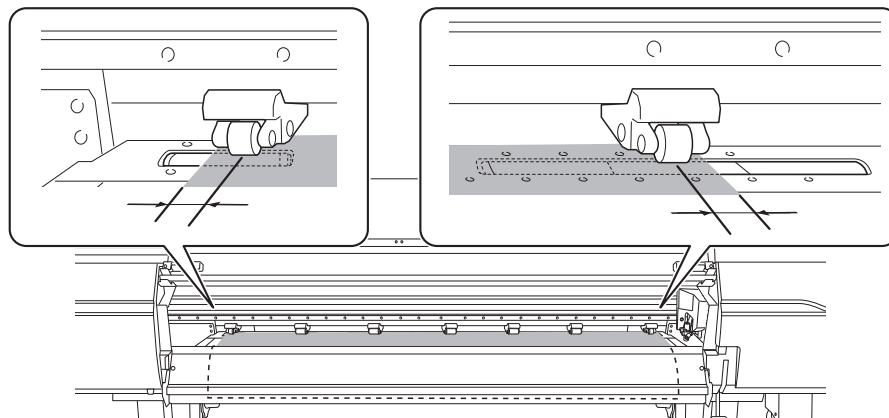

IMPORTANT

Be sure to use the left and right pinch rollers. The force with which the media is pinched varies between the middle pinch rollers and the left and right pinch rollers. Using the middle pinch rollers to pinch the media edges will lead to unstable media feeding.

MEMO

To smoothly move the pinch rollers, push down close to the rail.

- 10. Move the middle pinch rollers (B) over all the remaining grit rollers (A) covered by the media.**
There are grit patterns (C) wherever there are grit rollers.

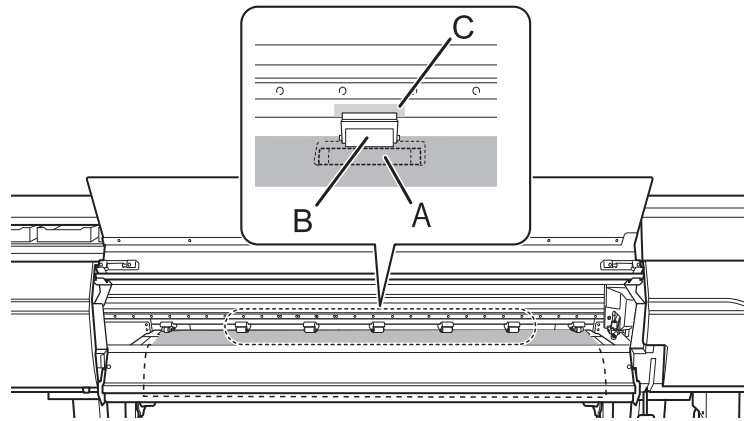

IMPORTANT

- Place the middle pinch rollers over all the grit patterns within the media width. If you have forgotten to place the middle pinch rollers, the media will be skewed during printing or will come loose, which will have an effect on the printing quality.
- The middle pinch roller will not lower onto the three grit rollers from the right end. Place the middle pinch roller on a grit roller other than these three.

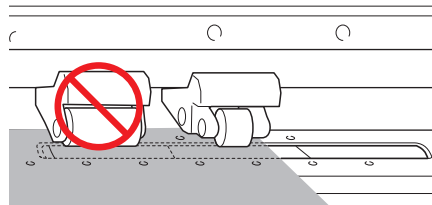

- There may be extra middle pinch rollers depending on the width of the media being used. Move the extra middle pinch rollers to positions where no grit patterns are present. Where no grit patterns are present, the middle pinch rollers will not come down.

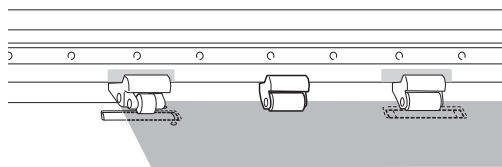

11. Lower the loading lever (front).

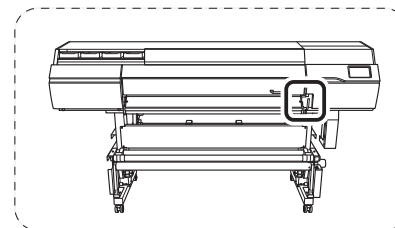
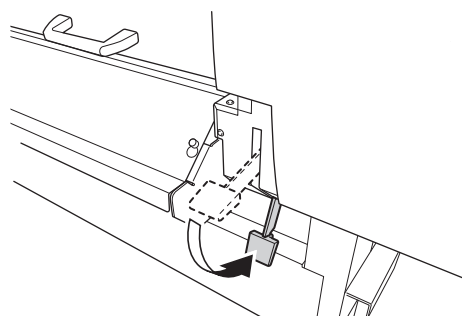

IMPORTANT

If you want to readjust the media position before securing it in place, redo the procedure from step 8.

12. Line up the edges of the media with the centers of the holes of the left and right media clamps.

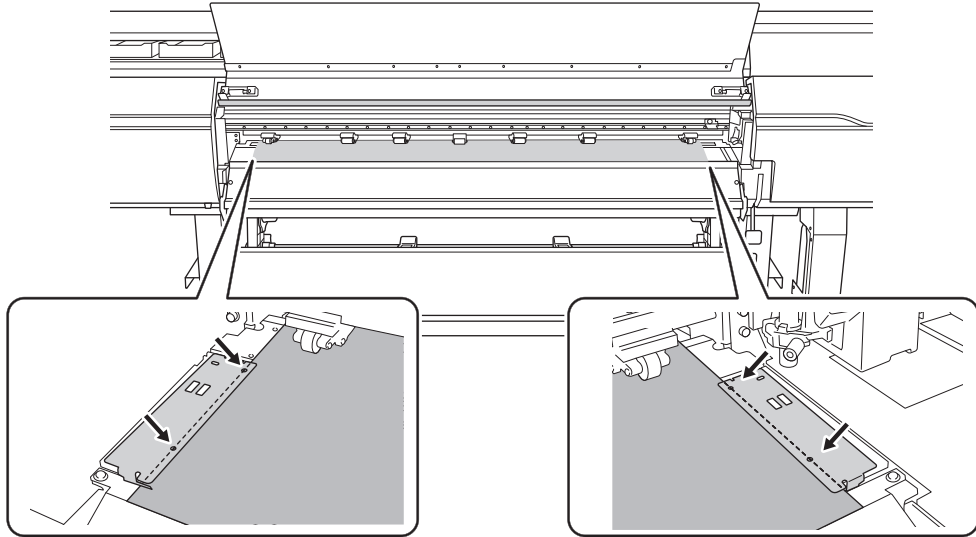

13. Close the front cover.

2. Select the media.

Procedure





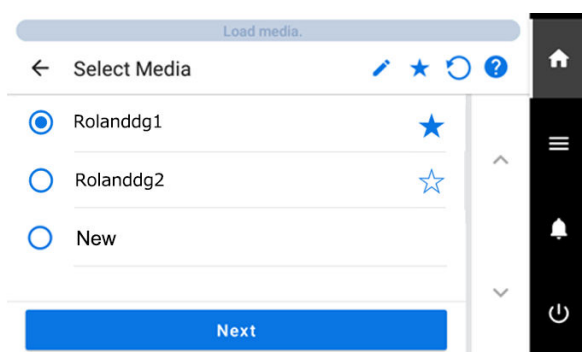



1. Tap  [Setup].

The registered media is displayed in a list.



2. Select the media name to use.

MEMO

- Tapping  makes it possible to search the registered media by keyword.
To reset the entered keyword, tap .
- Tapping  to the right of the media name will change the symbol to , and the media will be registered to Favorites.
Tap the favorites filter () at the top of the operation panel to turn the filter on () and show only favorited media.
Tap  to turn the Favorites filter off.
- Tap  to turn the Favorites filter off () and reset all keywords.
- Keyword searching and the Favorites filter can be used at the same time.

3. Tap [Next].

4. The [Setup Method] screen appears. Select whether to use the take-up unit.

5. Tap [Start Setup].

The cutting carriage moves and detects the width of the media and the positions of the media clamps. This operation is called initialization.

6. When [Printing Area (Width)] screen appears, use the following procedure to configure the settings.

MEMO

The media selected in step 2 is media whose printing area was set manually when registered as new media. The printing area must be set manually each time, so the [Printing Area (Width)] screen appears.

- (1) Tap [Change].

The [Set the right edge of the printing area within the area specified by the pinch rollers.] screen appears.

- (2) Hold down  to move the center of the blade (A) approximately 2 mm (0.08 in.) to the inside (B) from the left edge of the right pinch roller.

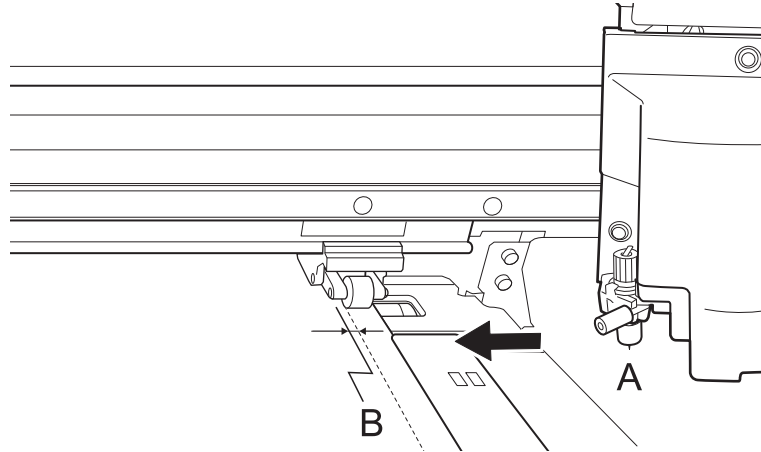

- (3) Tap [OK].

The [Set the left edge of the printing area within the area specified by the pinch rollers.] screen appears.

- (4) Hold down  to move the center of the blade (A) approximately 2 mm (0.08 in.) to the inside (B) from the right edge of the left pinch roller.

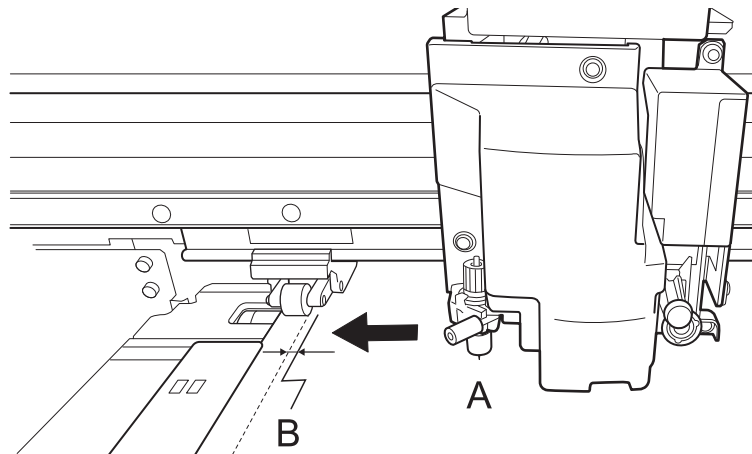

- (5) Tap [OK].

The set left and right positions are applied to the [Printing Area (Width)].

- (6) Tap [OK].

Checking before Output

LAN (Local Area Network) Settings

Check that you can perform communication through the LAN (Local Area Network).

The LAN is enabled if the status LED (②) on the LAN connector located on the side of the printer is lit in green.

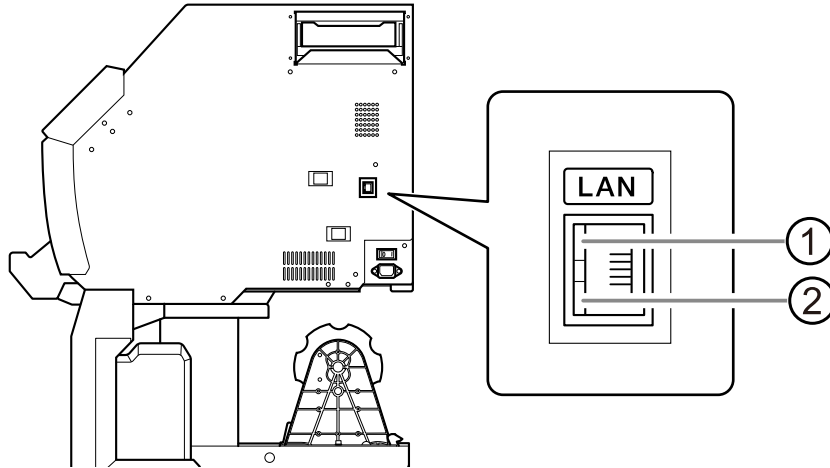

①	Activity LED	This flashes orange while data is being received from the network.
②	Status LED	This indicates the status of the communication function. When it lights in green, communication is possible.

Preventing Sedimentation in Inks

The precipitation of the ingredients in the ink disables printing in normal color. To mix the ingredients in the ink well, remove the pouch tray, shake it 50 times (for approximately 20 seconds), and then reinsert it.

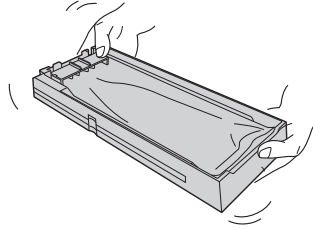

Shake the pouch trays once per week.

MEMO

To prevent ink precipitation, you can make the machine periodically display a message prompting you to mix the ink.
[P. 211 Showing/Hiding Notifications](#)

IMPORTANT

- Do not remove the ink pouches. Shake the entire pouch tray. Removing the ink pouches may lead to the ink leaking.
- Before shaking, wipe off any ink from around the mouth of the ink pouch. If you do not wipe off the ink, it may splatter when you shake the pouch tray.
- When you have finished mixing the ink, reinsert the pouch tray immediately. Taking time to reattach the ink cartridge will adversely affect the ink path.

Pausing and Canceling Output

You can pause and cancel output before it finishes.

Pausing and Resuming Output

IMPORTANT

We do not recommend resuming printing because horizontal bands are produced at the place where printing was paused.

MEMO

Some menu items can be operated during output, but return to the home screen before pausing output.

Procedure

1. During output, tap [Pause].
This pauses the printing operation.
2. Tap [Resume].

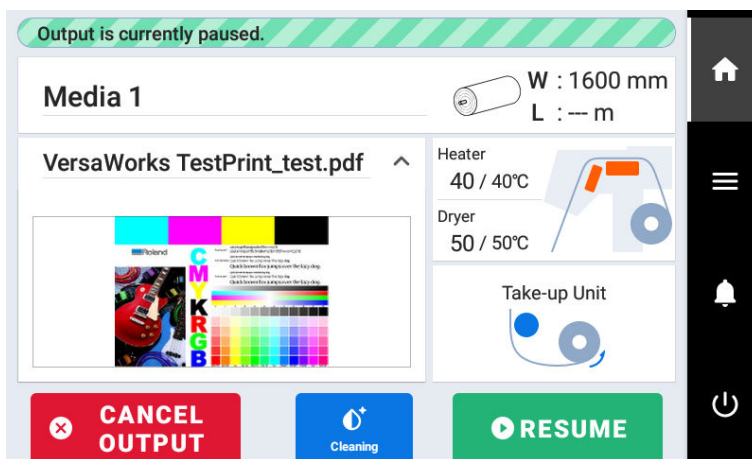

The printing operation resumes.

Canceling Output

Procedure

1. During output, tap [Pause].
This pauses the printing operation.
2. Tap [Cancel Output] when the following screen appears.

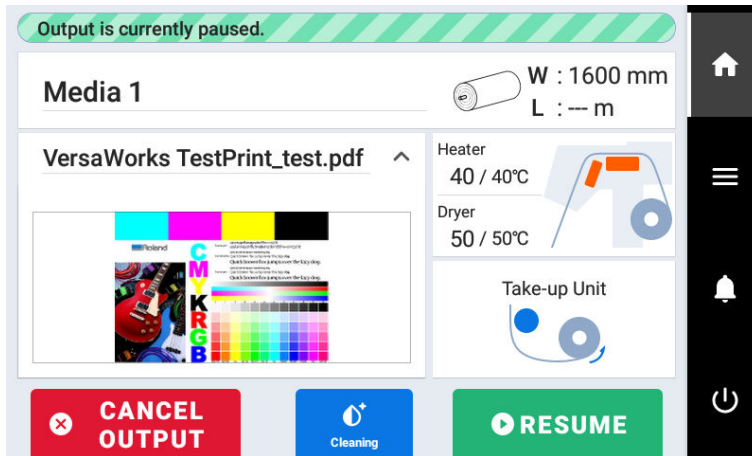

Output is canceled.



3. Stop sending the output data from the computer.

Separating the Media

After printing, use [Sheet Cutting] or [Perforated Sheet Cutting] to separate the media.

Procedure

1. Close the front cover.
2. If necessary, use the following procedure to set the separation position.

- (1) Tap .
- (2) Tap  [Move].
- (3) Tap  or  to set the media to the separation position.

The media is separated at the position in the following figure. Use the media clamp holes as a guideline for this position.

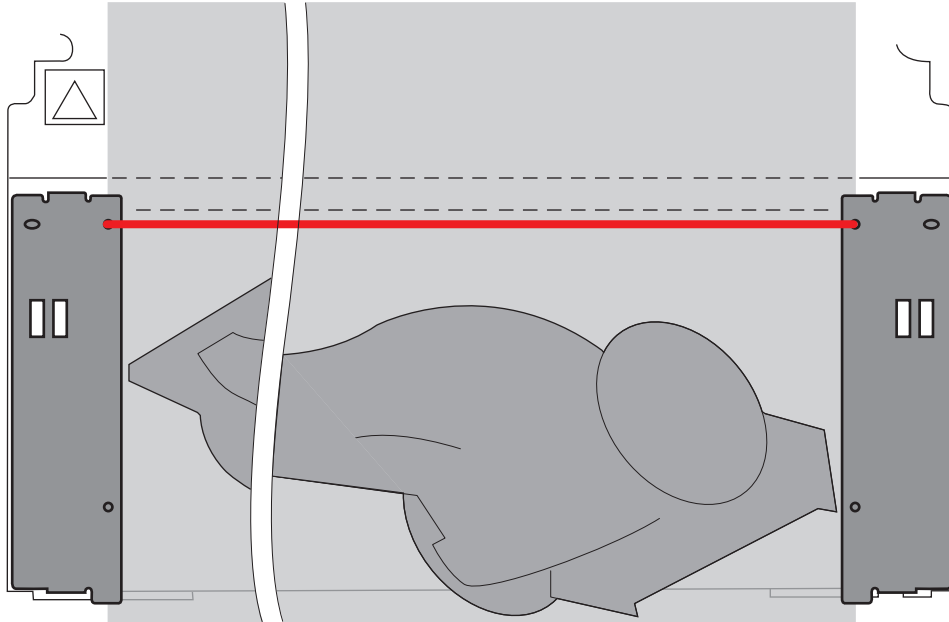

- (4) Tap [Set Base Point Here].
The separation position is set, and you are returned to the home screen.

3. Tap  [Sheet Cutting] on the operation panel.

4. Select the sheet cutting method.

[Sheet Cutting]	This separates the media.
[Perforated Sheet Cutting]	The media is perforated without being separated.

MEMO

If the media is separated even after you select **[Perforated Sheet Cutting]**, use **[Preferences]>[Perforated Sheet Cutting]** to change to the **[Increase Uncut Locations]** setting. If the media is heavy or has a large amount that is slack, it can be retained without being separated.

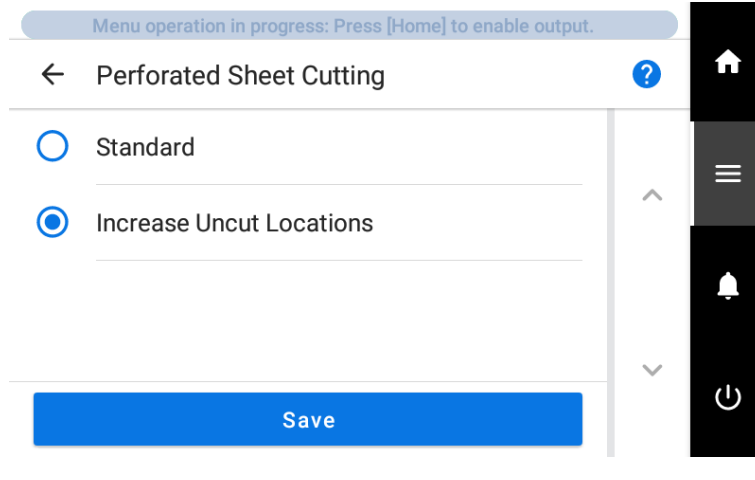
**5. Tap [Execute].**

The media is separated. If **[Perforated Sheet Cutting]** was selected in step 4, the media is perforated.

- You can configure settings in the software RIP for automatic media separation after output has finished. For information on how to configure the settings, refer to the documentation for the software RIP you are using.
- When using a take-up unit, take-up may be interrupted by media separation, so we recommend you turn off the automatic separation function or insert perforated sheet cutting with the included software RIP to ensure the media is not separated.

IMPORTANT**Separation Operations**

- If the distance from the end of the media to the separation location is short, separation may not be performed smoothly.

When Using a Take-up Unit

- Do not operate the manual switch on the take-up unit leaving the loading lever lowered. Tension is applied to the media by the take-up unit, so avoid operations that pull the media with excessive force.

Give Attention to the Media Composition

- For some types of media, separation is not possible.
- Some types of media may remain on the platen after separation. If the media remains on the platen, remove it by hand.

Removing Media from the Take-up Unit

When output is complete, separate the media, take up the media manually, and then remove the media.

⚠ WARNING

Handling roll media is an operation that must be performed by 2 persons or more, and care must be taken to prevent falls.

Attempting to lift heavy media in a manner that taxes your strength may cause physical injury. Also, if dropped, such items may cause injury.

Procedure

1. Lower the dancer roller toward the rear.

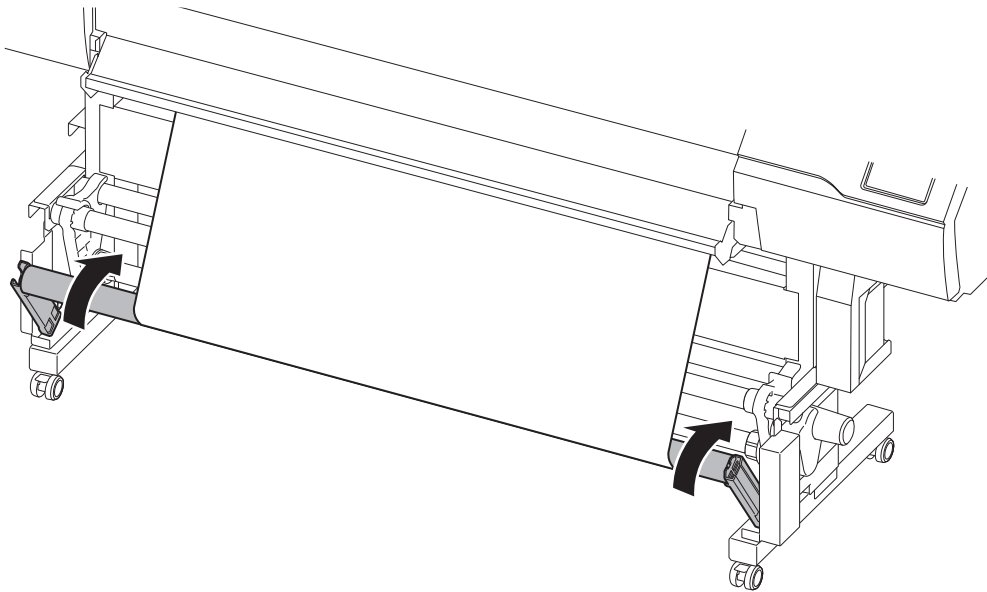

2. Close the front cover.

3. With the media held down, tap  [Sheet Cutting] on the operation panel.

4. Select [Sheet Cutting] and tap [Execute].

IMPORTANT

Give Attention to the Media Composition

- For some types of media, separation is not possible.
- Some types of media may remain on the platen after separation. If the media remains on the platen, remove it by hand.

5. Use the MANUAL switch to take-up the media.

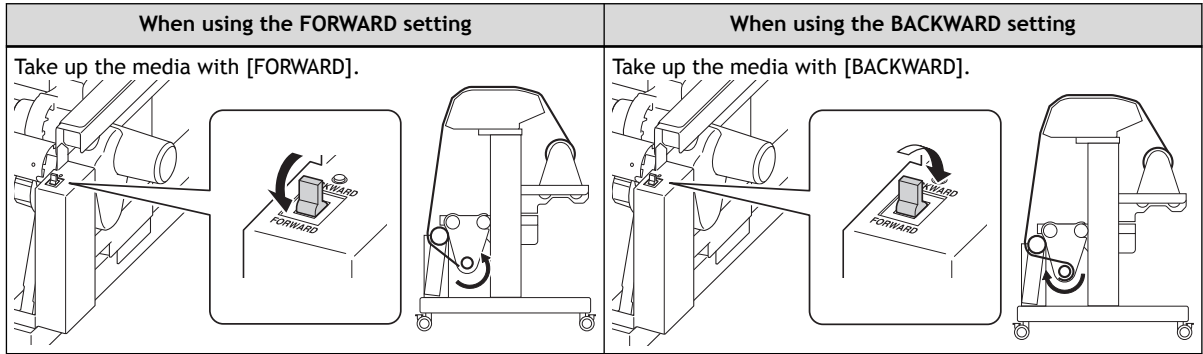

6. While supporting the media from below, loosen the securing lever on the left media holder.

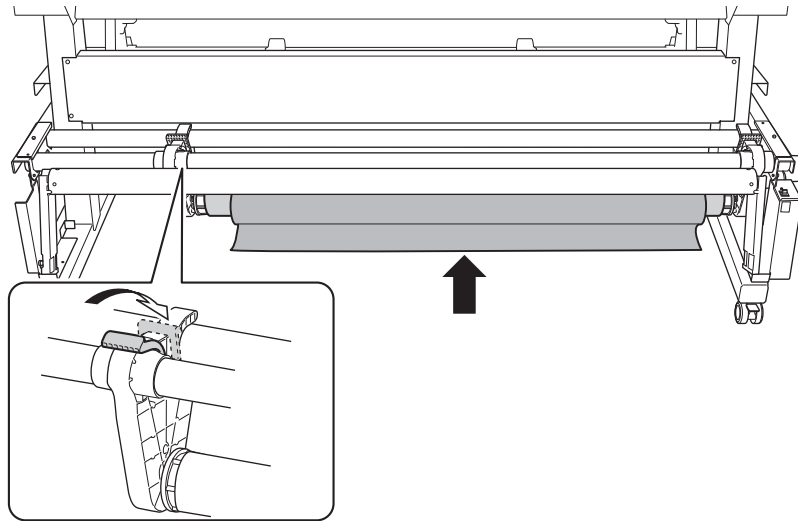

7. With the media supported, pull the paper tube and media from the end cap.

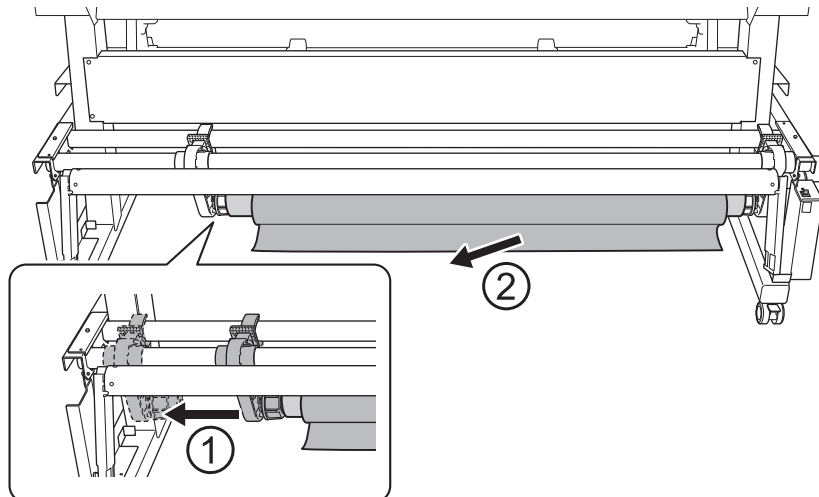

Ink Pouch Replacement

Out-of-ink Warnings

When an ink pouch runs out, printing pauses and [Ink Pouch Tray Error] appears.

[Empty] is displayed for ink that has run out. Check the display screen, and then replace the empty ink.

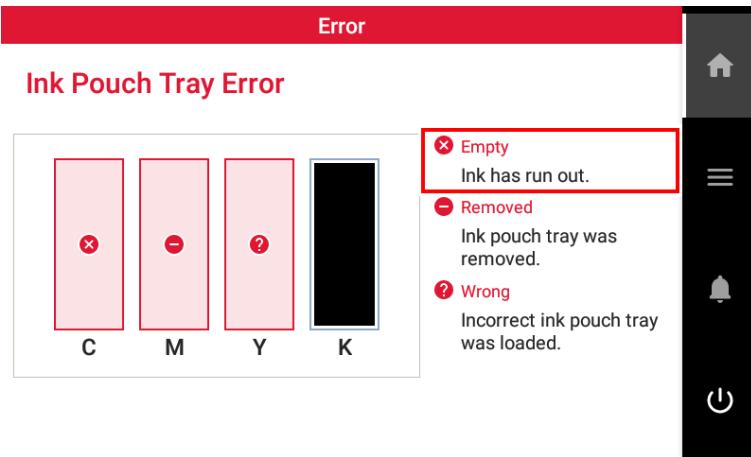

IMPORTANT

Never reuse an ink pouch when the machine shows a sign indicating no ink.

Occasionally the machine will show a sign indicating no ink even if there is a small amount of ink remaining in the pouch, but nevertheless do not use it. Such an ink pouch is in a state where drawing ink from it is impossible. Using it in such a state may force air into the ink path and cause printer malfunctions.

RELATED LINKS

- [P. 109 Ink Pouch Replacement](#)

Ink Pouch Replacement

⚠ WARNING

Never store ink, cleaning liquid, or discharged fluid in any of the following locations.

- Any location exposed to open flame
- Any location where high temperature may occur
- Near bleach or any other such oxidizing agent or explosive material
- Any location within the reach of children

Fire may be a danger. Accidental ingestion by children may pose a health hazard.

IMPORTANT

Precautions regarding ink pouch replacement

- Be sure to replace each pouch with an item of identical type and color.
- Never use an ink pouch that has already been used in another machine even if it is an identical type.
- Never mix different types of items.
- Never leave the machine with a pouch tray removed. The print heads may become clogged.
- Do not insert or remove pouch trays unless necessary. Ink may leak.
- Take care not to drop ink pouches.

IMPORTANT

Never reuse an ink pouch when the machine shows a sign indicating no ink.

Occasionally the machine will show a sign indicating no ink even if there is a small amount of ink remaining in the pouch, but nevertheless do not use it. Such an ink pouch is in a state where drawing ink from it is impossible. Using it in such a state may force air into the ink path and cause printer malfunctions.

Procedure

1. Remove the pouch tray for the color that you will replace.

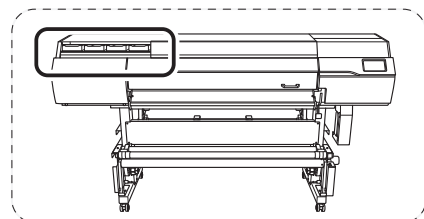
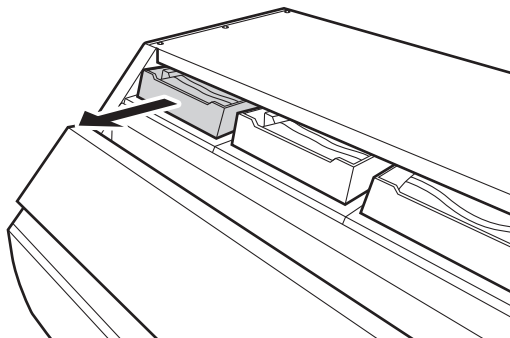

2. Remove the ink pouch from the pouch tray.

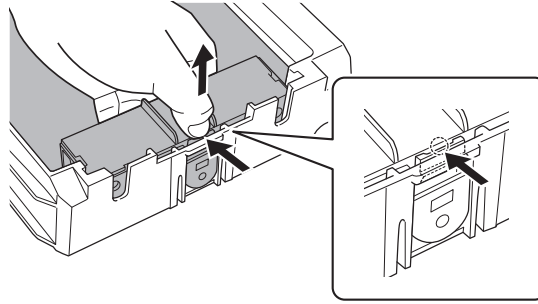

3. Set the new ink pouch in the pouch tray.

- (1) Align the protrusion on the pouch (A) with the groove on the pouch tray (B).

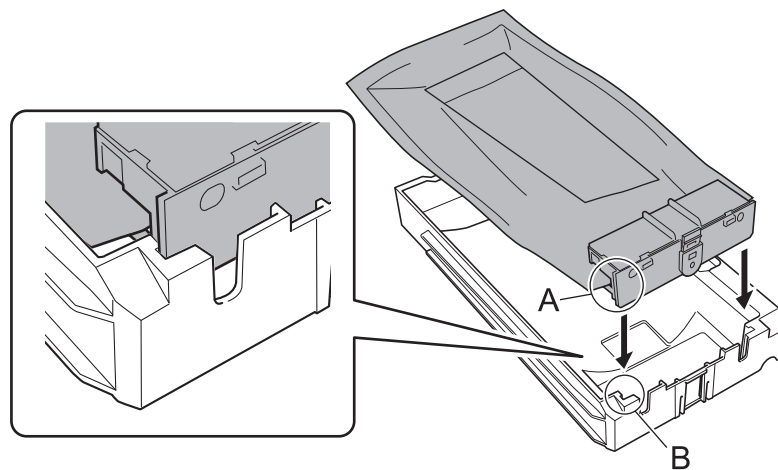

- (2) Push the ink pouch until you hear a click as the hook on the pouch is locked.

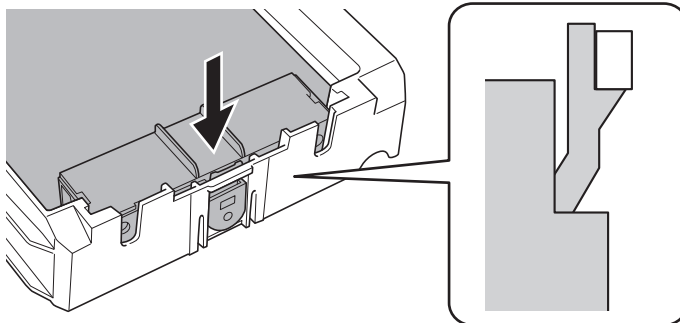

4. Gently shake the new ink pouch.

During storage, the ink components may have precipitated. When replacing an ink pouch, hold both ends of the pouch tray and shake 50 times (for around 20 seconds) horizontally with a stroke length of around 5 cm to ensure the ink mixes well.

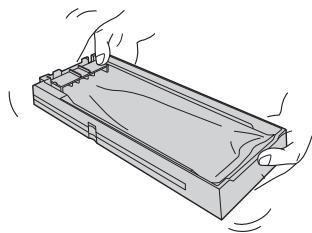

5. Set the pouch tray in the ink slot.

Insert the pouch tray as far as it will go.

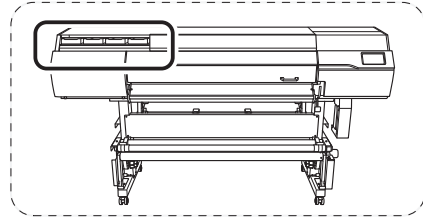
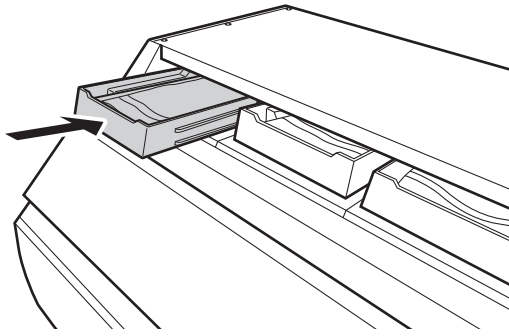

IMPORTANT

- Do not insert empty pouch trays. Doing so may force air into the ink path and cause printer malfunctions.
- Check the color names indicated on the ink slots and the ink pouches to set all the pouch trays in their correct positions.

Cleaning Liquid Pouch Replacement

Out-of-cleaning-liquid Warnings

If the cleaning liquid runs out, [Replace the cleaning liquid pouch.] appears on the screen. Tap [OK] to close this message.

You can also check the message by tapping

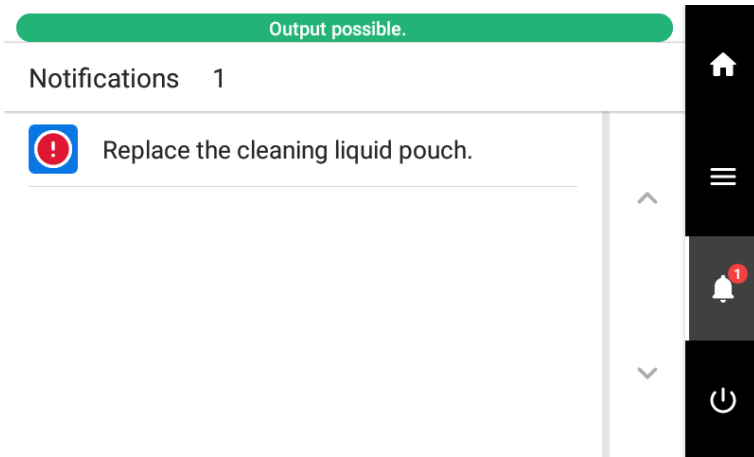

RELATED LINKS

- [P. 113 Cleaning Liquid Pouch Replacement](#)

Cleaning Liquid Pouch Replacement

⚠ WARNING

Never store ink, cleaning liquid, or discharged fluid in any of the following locations.

- Any location exposed to open flame
- Any location where high temperature may occur
- Near bleach or any other such oxidizing agent or explosive material
- Any location within the reach of children

Fire may be a danger. Accidental ingestion by children may pose a health hazard.

Procedure

1. Remove the pouch tray from the cleaning liquid slot.

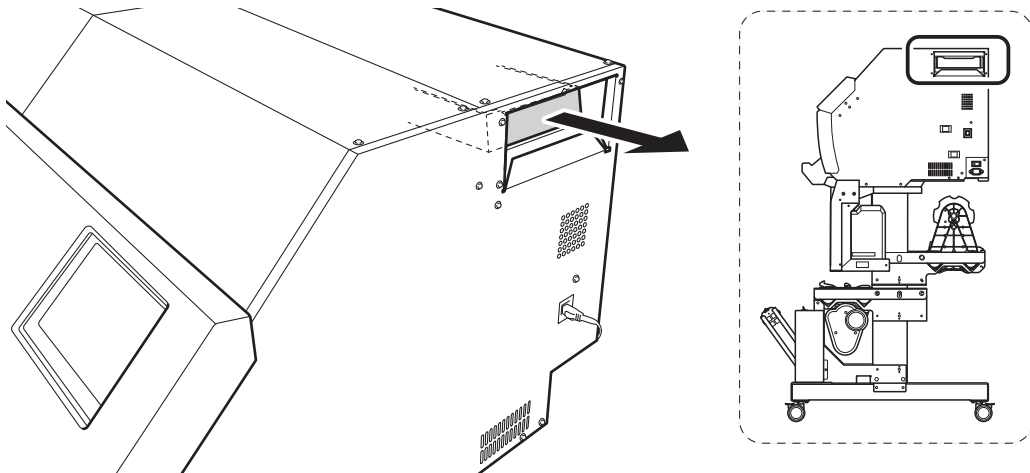

2. Remove the cleaning liquid pouch from the pouch tray.

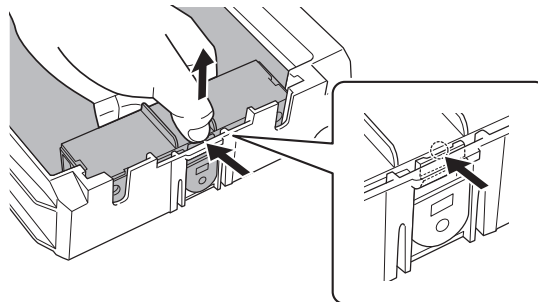

3. Set the new cleaning liquid pouch in the pouch tray.

- (1) Align the protrusion on the pouch (A) with the groove on the pouch tray (B).

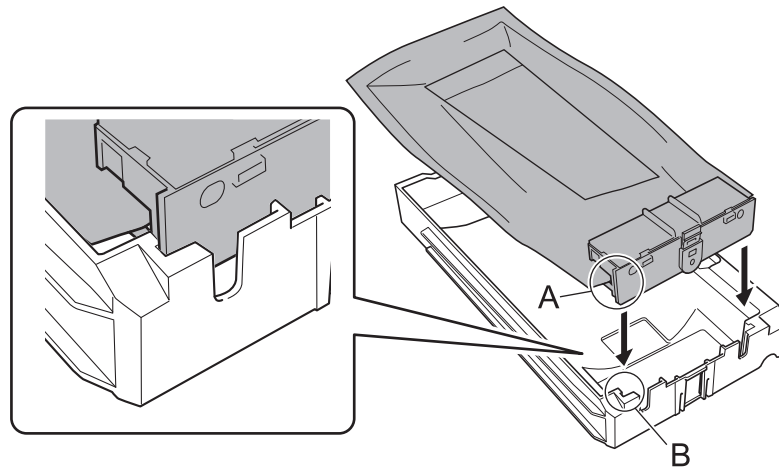

(2) Push the ink pouch until you hear a click as the hook on the pouch is locked.

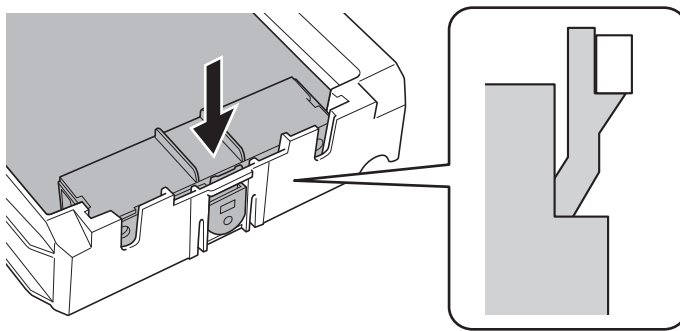

4. Set the pouch tray in the cleaning liquid slot.
Insert the pouch tray as far as it will go.

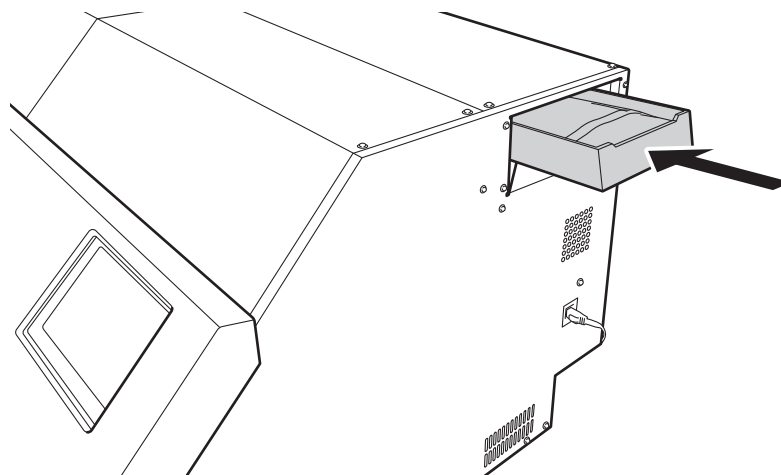

5. Tap [Yes] when the cleaning liquid pouch replacement confirmation screen appears.
If you tap [Yes] to reset the amount of cleaning liquid remaining, the cleaning liquid pouch will be identified as a new product.

Output Method

Printing Method

Preparations for Printing Output	117
Step 1: Performing a Nozzle Drop-out Test	117
Step 2: Normal Cleaning Method	118
Starting Output	119

Preparations for Printing Output

Step 1: Performing a Nozzle Drop-out Test

Before you carry out actual printing, perform a printing test to ensure no dot drop-out or dot displacement occurs. If dot drop-out or dot displacement occurs, perform cleaning of the print heads (normal cleaning).

MEMO

When performing printing tests successively, you can select **[Feed]** (vertical printing) or **[Scan]** (horizontal printing) as the printing position for the second and later tests in comparison to the first test.

[P. 206 Performing Printing Tests Arranged Horizontally](#)

Procedure

1. Tap  [Nozzle Drop-out Test] on the home screen.
2. Tap **[Execute]** next to **[Printing Test]**.
Printing of the test pattern starts.
3. Check whether there is dot drop-out or dot displacement in the test pattern.
Missing blocks indicate dot drop-out. Collapsed or inclined blocks indicate dot displacement.

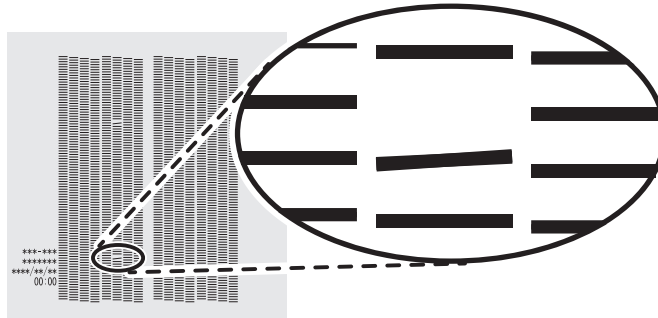

4. If you have opened the front cover, close it.
If no dot drop-out or dot displacement occurs, preparations for output are finished.

RELATED LINKS

- [P. 243 When Dot Drop-out or Dot Displacement Occurs](#)

Step 2: Normal Cleaning Method

Procedure

1. Tap [Cleaning].

2. Tap [Normal Cleaning].

3. Tap [Execute].

Cleaning will start. The status is displayed as [Normal cleaning in progress.] at the top of the operation panel.

On completion, you will return to the original screen.

4. Perform a printing test again.

5. Check to make sure the dot drop-out or dot displacement has been corrected.

If the problem persists, try performing normal cleaning again. If the printer has been used for a long period, dot drop-outs may not be fixed even after performing normal cleaning two or three times. If this is the case, clean using a different method.

RELATED LINKS

- [P. 117 Performing a Nozzle Drop-out Test](#)
- [P. 244 When Normal Cleaning Is Not Effective](#)

Starting Output

⚠ WARNING

Never touch the print-head carriage while output is in progress.

The print-head carriage moves at high speed. Coming into contact with the moving carriage may cause injury.

⚠ CAUTION

Do not touch the dancer roller needlessly.

The media take-up unit and feeder may move suddenly, which may result in injury.

Procedure

1. Shake the pouch trays once per week.

Shake a pouch tray 50 times (for approximately 20 seconds), and then reinsert it. The precipitation of the ingredients in the ink disables printing in normal color. So that the ink mixes well, shake the pouch tray horizontally with a stroke length of around 5 cm (2 in.) from each end of the tray.

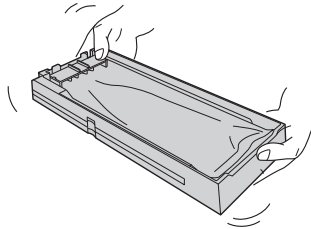

IMPORTANT

- Do not remove the ink pouches. Shake the entire pouch tray. Removing the ink pouches may lead to the ink leaking.
- Before shaking, wipe off any ink from around the mouth of the ink pouch. If you do not wipe off the ink, it may splatter when you shake the pouch tray.
- When you have finished mixing the ink, reinsert the pouch tray immediately. Taking time to reattach the ink cartridge will adversely affect the ink path.

2. Close the front cover.

3. Make sure [Output possible.] is displayed at the top of the operation panel.

4. Send the output data from the computer.

For information on how to create the output data, refer to the documentation for the software RIP.

MEMO

- When you send the output data, [Ink circulation in progress.] or [Normal cleaning in progress.] may be displayed on the screen. These indicate the preparation operations performed before output. Output will begin after the time displayed on the screen elapses.
- If [Heater warm up in progress. Please wait.] is displayed, wait until the set temperature is reached.
- The data being output can be viewed as an image. Tap  shown in the following figure to switch to the remaining ink screen. Tap this icon again to return to the screen for checking the data being output. However, this functionality is limited to software RIPs that support the display of the output data image (thumbnail).

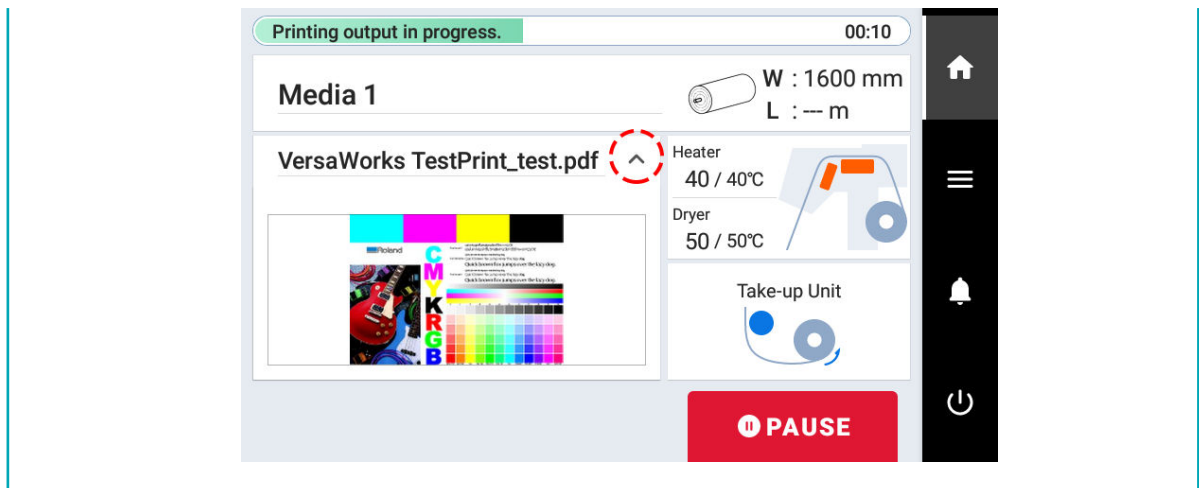

IMPORTANT

Output Is Not Possible in These Situations

- The machine does not run when a cover (front, left, or right) is open.
- Data from the computer is not accepted when [Load media.] is displayed.
- Output does not start while [Heater warm up in progress. Please wait.] is displayed.
- On menu screens where [Menu operation in progress: Press [Home] to enable output.] is displayed, output doesn't start even when data is sent from the computer. When you return to a menu item where output is possible or tap  to return to the home screen, output starts.

Points that must be observed

- Never open a cover (front, left, or right) while output is in progress. Doing so interrupts printing.
- When you are performing printing, clamp the edges of the media with the media clamps. Otherwise, the edges of the media may warp and catch on the print heads.
- During output, do not touch the media. Doing so may obstruct the media feed or cause the media to rub against the print heads, which may result in a paper jam or damage to the heads.
- Keep the loading lever raised when the machine is not in use.

When not using the machine, remove any media and store it in a suitable environment.

- If the machine is left with the media loaded, the media may be damaged, which may adversely affect printing. When not using the machine, remove any media and store it in a suitable environment.

RELATED LINKS

- [P. 164 Changing the Print Heater Temperature](#)
- [P. 166 Changing the Dryer Temperature](#)
- [P. 171 Switching Off the Print Heater and Dryer Together](#)

Cutting Method

Preparations for Cutting Output.....	122
Step 1: Switching Off the Print Heater and Dryer	122
Step 2: Preventing Pulling of the Media with Undue Force	123
Step 3: Adjusting Cutting	124
Starting Output	125

Preparations for Cutting Output

Step 1: Switching Off the Print Heater and Dryer

Procedure

1. Tap  to display the home screen.

2. Tap the following part.

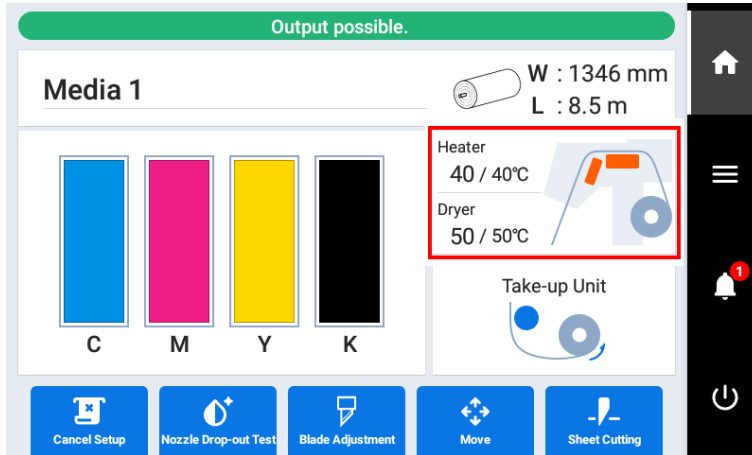

3. Tap [Heater Power] to turn it off as shown below.

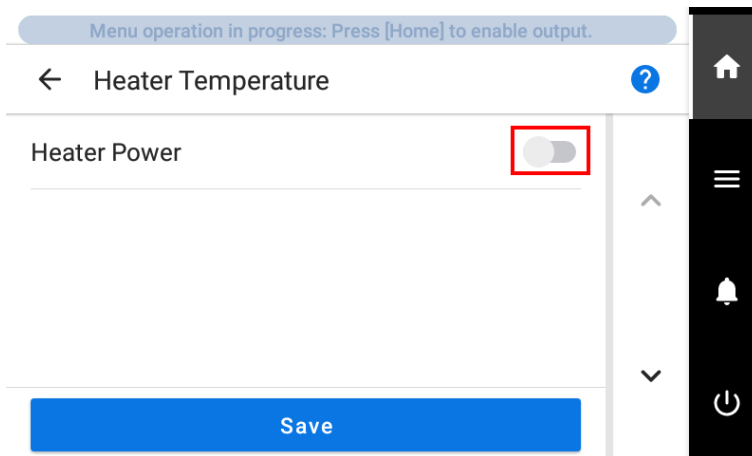



4. Tap [Save] to confirm your entry.
The [Print Heater] and [Dryer] settings turn off.

5. Tap  to go back to the original screen.

Step 2: Preventing Pulling of the Media with Undue Force

Procedure

1. Tap  .
2. Tap [Preferences]>[Prefeeding at Output].
3. Select [Enable].
4. Press [Save] to confirm your entry.
5. Tap  to go back to the original screen.

Step 3: Adjusting Cutting

For high-quality cutting, we recommend carrying out a cutting test to check the cutting quality for the media before you perform actual cutting. Adjust the blade force depending on the cutting quality.

Procedure

1. Close the front cover.
2. Tap  [Blade Adjustment] on the home screen.
3. Tap [Execute] next to [Cutting Test].
The test pattern is cut.
4. Peel off the cut shapes and change the [Blade Adjustment] settings according to the cutting quality.

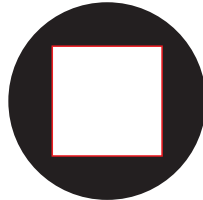

- **Two shapes are peeled off separately**
You do not need to perform the setting because the blade force is appropriate.
 - **Two shapes are peeled off together**
Increase the blade force.
 - **Backing paper is also cut**
Decrease the blade force.
5. Tap [Save].
The changed settings are saved.
 6. Tap [Execute] next to [Cutting Test].
The test pattern is cut.
 7. Check whether the correction was successful.

In the [Blade Adjustment] menu, you can also make settings for other cutting conditions in addition to the blade force.

RELATED LINKS

- [P. 173 Fine-tuning the Cutting Conditions](#)

Starting Output

⚠ WARNING

Never touch the print-head carriage while output is in progress.

The print-head carriage moves at high speed. Coming into contact with the moving carriage may cause injury.

⚠ CAUTION

Do not touch the dancer roller needlessly.

The media take-up unit and feeder may move suddenly, which may result in injury.

Procedure

1. Close the front cover.

2. Tap  to display the home screen.

3. Make sure [Output possible.] is displayed at the top of the operation panel.

4. Send the output data from the computer.

For information on how to create the output data, refer to the documentation for the software RIP.

IMPORTANT

Output Is Not Possible in These Situations

- The machine does not run when a cover (front, left, or right) is open.
- Data from the computer is not accepted when [Load media.] is displayed.
- On menu screens where [Menu operation in progress: Press [Home] to enable output.] is displayed, output doesn't start even when data is sent from the computer. When you return to a menu item where output

is possible or tap  to return to the home screen, output starts.

Points that must be observed

- Never open a cover (front, left, or right) while output is in progress. Doing so interrupts printing.
- During output, do not touch the media. Doing so may obstruct the media feed or cause the media to rub against the print heads, which may result in a paper jam or damage to the heads.
- Keep the loading lever raised when the machine is not in use.

When not using the machine, remove any media and store it in a suitable environment.

- If the machine is left with the media loaded, the media may be damaged, which may adversely affect printing. When not using the machine, remove any media and store it in a suitable environment.

Printing and Cutting Method

Preparations for Printing and Cutting Output	127
Step 1: Performing a Nozzle Drop-out Test	127
Step 2: Normal Cleaning Method	128
Step 3: Adjusting Cutting	129
Step 4: Correcting the Misalignment of Printing and Cutting	130
Starting Output	132

Preparations for Printing and Cutting Output

Step 1: Performing a Nozzle Drop-out Test

Before you carry out actual printing, perform a printing test to ensure no dot drop-out or dot displacement occurs. If dot drop-out or dot displacement occurs, perform cleaning of the print heads (normal cleaning).

MEMO

When performing printing tests successively, you can select **[Feed]** (vertical printing) or **[Scan]** (horizontal printing) as the printing position for the second and later tests in comparison to the first test.

[P. 206 Performing Printing Tests Arranged Horizontally](#)

Procedure

1. Tap  [Nozzle Drop-out Test] on the home screen.
2. Tap [Execute] next to [Printing Test].
Printing of the test pattern starts.
3. Check whether there is dot drop-out or dot displacement in the test pattern.
Missing blocks indicate dot drop-out. Collapsed or inclined blocks indicate dot displacement.

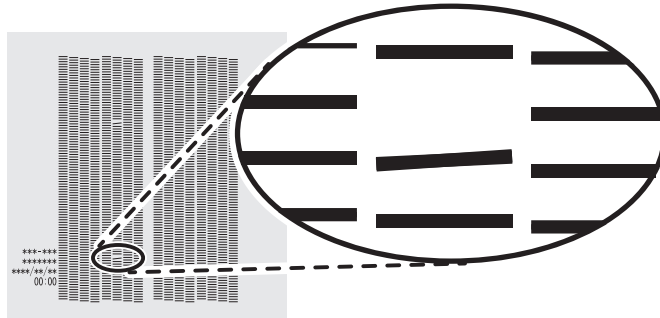

4. If you have opened the front cover, close it.
If no dot drop-out or dot displacement occurs, preparations for output are finished.

RELATED LINKS

- [P. 243 When Dot Drop-out or Dot Displacement Occurs](#)

Step 2: Normal Cleaning Method

Procedure

1. Tap [Cleaning].

2. Tap [Normal Cleaning].

3. Tap [Execute].

Cleaning will start. The status is displayed as [Normal cleaning in progress.] at the top of the operation panel.

On completion, you will return to the original screen.

4. Perform a printing test again.

5. Check to make sure the dot drop-out or dot displacement has been corrected.

If the problem persists, try performing normal cleaning again. If the printer has been used for a long period, dot drop-outs may not be fixed even after performing normal cleaning two or three times. If this is the case, clean using a different method.

RELATED LINKS

- [P. 117 Performing a Nozzle Drop-out Test](#)
- [P. 244 When Normal Cleaning Is Not Effective](#)

Step 3: Adjusting Cutting

For high-quality cutting, we recommend carrying out a cutting test to check the cutting quality for the media before you perform actual cutting. Adjust the blade force depending on the cutting quality.

Procedure

1. Close the front cover.
2. Tap  [Blade Adjustment] on the home screen.
3. Tap [Execute] next to [Cutting Test].
The test pattern is cut.
4. Peel off the cut shapes and change the [Blade Adjustment] settings according to the cutting quality.

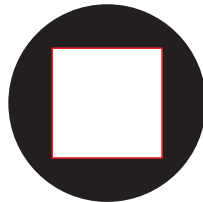

- **Two shapes are peeled off separately**
You do not need to perform the setting because the blade force is appropriate.
- **Two shapes are peeled off together**
Increase the blade force.
- **Backing paper is also cut**
Decrease the blade force.

5. Tap [Save].
The changed settings are saved.
6. Tap [Execute] next to [Cutting Test].
The test pattern is cut.
7. Check whether the correction was successful.

In the [Blade Adjustment] menu, you can also make settings for other cutting conditions in addition to the blade force.

RELATED LINKS

- [P. 173 Fine-tuning the Cutting Conditions](#)

Step 4: Correcting the Misalignment of Printing and Cutting

Procedure

1. Tap .
2. Tap [Media Settings]>[Cutting Settings]>[Print & Cut Position Adjustment].
3. Tap [Execute] next to [Printing Test 1 (Misalignment Check)].
Printing Test 1 is printed and cut. The test pattern is printed at each edge of the media.

MEMO

If the media is tilted, the positions at the edges will be misaligned. You can also adjust for misalignments due to the media being tilted by printing the test pattern at each edge.

4. Check the result of Printing Test 1.

Check whether the printing position (shaded part) and the cutting position (red line) are aligned. An example of the printing position and the cutting position being misaligned is shown in the following figure.

[F] indicates the feed direction of the media (the feed direction) and [S] indicates the direction of print head movement (the scan direction).

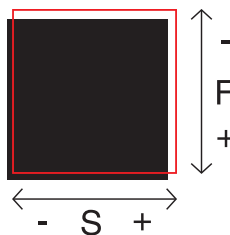



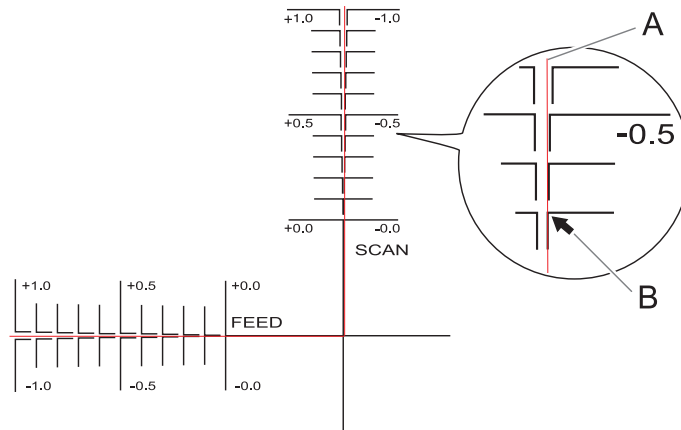

If the printing position and the cutting position are aligned, no corrections are necessary.

If the printing position and the cutting position are not aligned, proceed to the next procedure.

5. Tap [Execute] next to [Printing Test 2 (Correction Values)].
Printing Test 2 is printed and cut.
6. Check the correction values from the Printing Test 2 condition.
The point where the cutting line (A) intersects the correction-value scale (B) is the correction value. In the following figure, the correction value is "-0.3."
Check the media feed direction (the feed direction) and the direction of print head movement (the scan direction).





7. Set the correction values in the feed direction of the media (the feed direction) and the direction of print head movement (the scan direction).

- (1) Tap  or  next to [Correction Value (Feed)] to set the correction value in the feed direction of the media (the feed direction).
- (2) Tap  or  next to [Correction Value (Scan)] to set the correction value in the direction of print head movement (the scan direction).

8. Tap [Save].

The correction values are saved.

9. Tap [Execute] next to [Printing Test 1 (Misalignment Check)].

Printing Test 1 is printed and cut. If the printing and cutting lines are aligned, adjustment is complete. If further adjustment is needed, tap  or  next to [Correction Value (Feed)] and [Correction Value (Scan)] to fine-tune the printing and cutting position, and then [Save] the values.

MEMO

Default settings

- [Correction Value (Feed)] (correction value of the media feed direction): 0.00 mm
- [Correction Value (Scan)] (correction value of the print head movement direction): 0.00 mm

10. Tap  to go back to the original screen.

Starting Output

⚠ WARNING

Never touch the print-head carriage while output is in progress.

The print-head carriage moves at high speed. Coming into contact with the moving carriage may cause injury.

⚠ CAUTION

Do not touch the dancer roller needlessly.

The media take-up unit and feeder may move suddenly, which may result in injury.

Procedure

1. Shake the pouch trays once per week.

Shake a pouch tray 50 times (for approximately 20 seconds), and then reinsert it. The precipitation of the ingredients in the ink disables printing in normal color. So that the ink mixes well, shake the pouch tray horizontally with a stroke length of around 5 cm (2 in.) from each end of the tray.

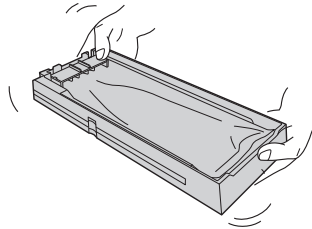

IMPORTANT

- Do not remove the ink pouches. Shake the entire pouch tray. Removing the ink pouches may lead to the ink leaking.
- Before shaking, wipe off any ink from around the mouth of the ink pouch. If you do not wipe off the ink, it may splatter when you shake the pouch tray.
- When you have finished mixing the ink, reinsert the pouch tray immediately. Taking time to reattach the ink cartridge will adversely affect the ink path.

2. Close the front cover.

3. Make sure [Output possible.] is displayed at the top of the operation panel.

4. Send the output data from the computer.

For information on how to create the output data, refer to the documentation for the software RIP.

MEMO

- When you send the output data, [Ink circulation in progress.] or [Normal cleaning in progress.] may be displayed on the screen. These indicate the preparation operations performed before output. Output will begin after the time displayed on the screen elapses.
- If [Heater warm up in progress. Please wait.] is displayed, wait until the set temperature is reached.
- The data being output can be viewed as an image. Tap  shown in the following figure to switch to the remaining ink screen. Tap this icon again to return to the screen for checking the data being output. However, this functionality is limited to software RIPs that support the display of the output data image (thumbnail).

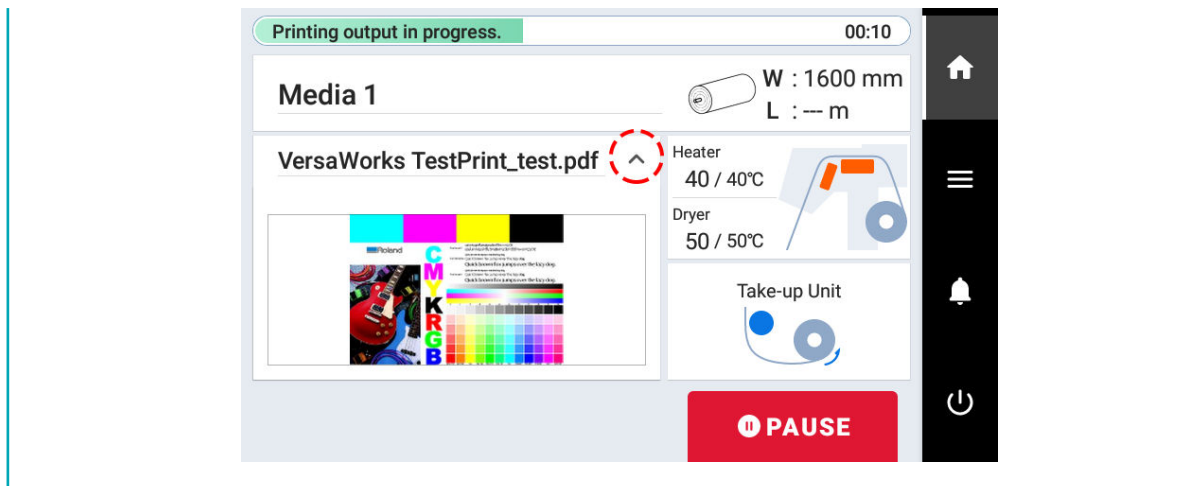

IMPORTANT

Output Is Not Possible in These Situations

- The machine does not run when a cover (front, left, or right) is open.
- Data from the computer is not accepted when [Load media.] is displayed.
- Output does not start while [Heater warm up in progress. Please wait.] is displayed.
- On menu screens where [Menu operation in progress: Press [Home] to enable output.] is displayed, output doesn't start even when data is sent from the computer. When you return to a menu item where output is possible or tap  to return to the home screen, output starts.

Points that must be observed

- Never open a cover (front, left, or right) while output is in progress. Doing so interrupts printing.
- When you are performing printing, clamp the edges of the media with the media clamps. Otherwise, the edges of the media may warp and catch on the print heads.
- During output, do not touch the media. Doing so may obstruct the media feed or cause the media to rub against the print heads, which may result in a paper jam or damage to the heads.
- Keep the loading lever raised when the machine is not in use.

When not using the machine, remove any media and store it in a suitable environment.

- If the machine is left with the media loaded, the media may be damaged, which may adversely affect printing. When not using the machine, remove any media and store it in a suitable environment.

RELATED LINKS

- [P. 164 Changing the Print Heater Temperature](#)
- [P. 166 Changing the Dryer Temperature](#)
- [P. 171 Switching Off the Print Heater and Dryer Together](#)

How to Cut with Crop Marks

Preparations for Output with Crop Marks	135
Step 1: Performing a Nozzle Drop-out Test	135
Step 2: Normal Cleaning Method	136
Step 3: Adjusting Cutting	137
Step 4: Correct the misalignment of printing and cutting with crop marks at the same time.	138
Starting Output with Crop Marks	140
Preparations for Cutting Output	142
Step 1: Loading Media with Crop Marks	142
Step 2: Switching Off the Print Heater and Dryer	143
Step 3: Preventing Pulling of the Media with Undue Force	144
Starting Cutting Output	145

Preparations for Output with Crop Marks

What Is Cutting with Crop Marks?

If you are removing the printed media and loading it again in order to cut it (for example, if you are processing the media such as laminating after printing, and then loading this media again for cutting), you have to align the printing and cutting positions. By printing the data together with crop marks, you can make it possible to align the positions using the crop marks when you load the media again to cut it. In this manual, this printing method is referred to as "cutting with crop marks."

"Crop marks" are marks used to align positions. They are also called "alignment marks."

Step 1: Performing a Nozzle Drop-out Test

Before you carry out actual printing, perform a printing test to ensure no dot drop-out or dot displacement occurs. If dot drop-out or dot displacement occurs, perform cleaning of the print heads (normal cleaning).

MEMO

When performing printing tests successively, you can select [Feed] (vertical printing) or [Scan] (horizontal printing) as the printing position for the second and later tests in comparison to the first test.

[P. 206 Performing Printing Tests Arranged Horizontally](#)

Procedure

1. Tap  [Nozzle Drop-out Test] on the home screen.
2. Tap [Execute] next to [Printing Test].
Printing of the test pattern starts.
3. Check whether there is dot drop-out or dot displacement in the test pattern.
Missing blocks indicate dot drop-out. Collapsed or inclined blocks indicate dot displacement.

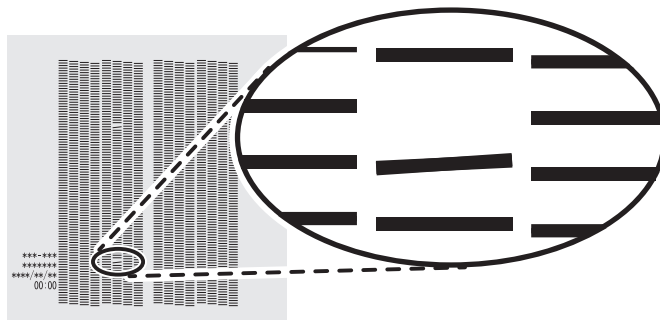

4. If you have opened the front cover, close it.
If no dot drop-out or dot displacement occurs, preparations for output are finished.

RELATED LINKS

- [P. 243 When Dot Drop-out or Dot Displacement Occurs](#)

Step 2: Normal Cleaning Method

Procedure

1. Tap [Cleaning].

2. Tap [Normal Cleaning].

3. Tap [Execute].

Cleaning will start. The status is displayed as [Normal cleaning in progress.] at the top of the operation panel.

On completion, you will return to the original screen.

4. Perform a printing test again.

5. Check to make sure the dot drop-out or dot displacement has been corrected.

If the problem persists, try performing normal cleaning again. If the printer has been used for a long period, dot drop-outs may not be fixed even after performing normal cleaning two or three times. If this is the case, clean using a different method.

RELATED LINKS

- [P. 117 Performing a Nozzle Drop-out Test](#)
- [P. 244 When Normal Cleaning Is Not Effective](#)

Step 3: Adjusting Cutting

For high-quality cutting, we recommend carrying out a cutting test to check the cutting quality for the media before you perform actual cutting. Adjust the blade force depending on the cutting quality.

Procedure

1. Close the front cover.
2. Tap  [Blade Adjustment] on the home screen.
3. Tap [Execute] next to [Cutting Test].
The test pattern is cut.
4. Peel off the cut shapes and change the [Blade Adjustment] settings according to the cutting quality.

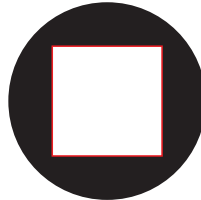

- **Two shapes are peeled off separately**
You do not need to perform the setting because the blade force is appropriate.
- **Two shapes are peeled off together**
Increase the blade force.
- **Backing paper is also cut**
Decrease the blade force.

5. Tap [Save].
The changed settings are saved.
6. Tap [Execute] next to [Cutting Test].
The test pattern is cut.
7. Check whether the correction was successful.

In the [Blade Adjustment] menu, you can also make settings for other cutting conditions in addition to the blade force.



RELATED LINKS

- [P. 173 Fine-tuning the Cutting Conditions](#)

Step 4: Correct the misalignment of printing and cutting with crop marks at the same time.

Use the following procedure to print the crop marks and cut the media, checking for misalignment in the positions. In this section, the crop marks are printed simply, and then the crop marks are read and a cutting test is performed without removing the media. To simulate the actual process—printing crop marks, removing the media, and then performing post-processing such as laminating—before loading the media and checking for cutting position misalignment, turn on **[Separate Test for Printing/Cutting with Crop Marks]**. For more information, refer to [Correcting the Misalignment of Printing and Cutting with Crop Marks \(Separate Test for Printing/Cutting with Crop Marks\)](#)(P. 189).

Procedure

1. Tap .
2. Tap [Media Settings]>[Cutting Settings]>[Crop Cut Position Adjustment].
3. Tap  next to [Separate Test for Printing/Cutting with Crop Marks] to turn it off.
4. Tap [Execute] next to [Printing Test 1 (Misalignment Check)].
Printing Test 1 is printed and cut. One test pattern is printed on the media.

5. Check Printing Test 1.

Check whether the printing position (shaded part) and the cutting position (red line) are aligned. An example of the printing position and the cutting position being misaligned is shown in the following figure.

[F] indicates the feed direction of the media (the feed direction) and [S] indicates the direction of print head movement (the scan direction).

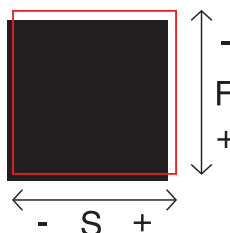

If the printing position and the cutting position are aligned, no corrections are necessary.

If the printing position and the cutting position are not aligned, proceed to the next procedure.

6. Tap [Execute] next to [Printing Test 2 (Correction Values)].
Printing Test 2 is printed and cut.



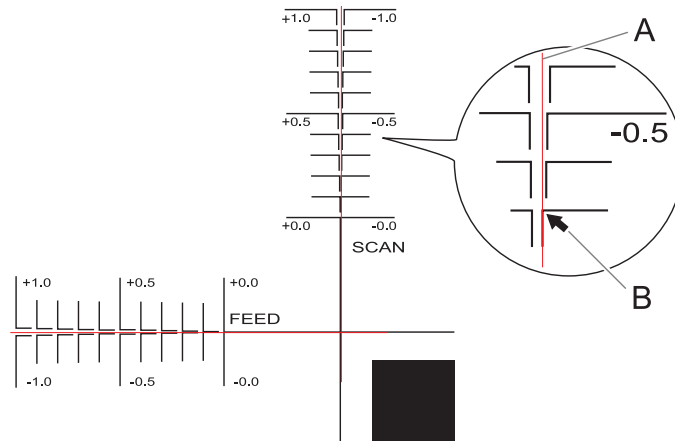

7. Check the correction values from the Printing Test 2 condition.

The point where the cutting line (A) intersects the correction-value scale (B) is the correction value. In the following figure, the correction value is "-0.3."

Check the media feed direction (the feed direction) and the direction of print head movement (the scan direction).





8. Set the correction values in the feed direction of the media (the feed direction) and the direction of print head movement (the scan direction).

- (1) Tap  or  next to [Correction Value (Feed)] to set the correction value in the feed direction of the media (the feed direction).
- (2) Tap  or  next to [Correction Value (Scan)] to set the correction value in the direction of print head movement (the scan direction).

9. Tap [Save].

The correction values are saved.

10. Tap [Execute] next to [Printing Test 1 (Misalignment Check)].

Printing Test 1 is printed and cut. If the printing and cutting lines are aligned, adjustment is complete. If further adjustment is needed, tap  or  next to [Correction Value (Feed)] and [Correction Value (Scan)] to fine-tune the printing and cutting position, and then [Save] the values.

MEMO

- Default settings
 - [Correction Value (Feed)] (correction value of the media feed direction): 0.00 mm
 - [Correction Value (Scan)] (correction value of the print head movement direction): 0.00 mm
- Depending on the changes in the condition of media caused by laminating and the loading position of the media before cutting, the positioning of cutting may be misaligned. In such cases, correct the misalignment of printing and cutting with crop marks.

11. Tap  to go back to the original screen.

RELATED LINKS

- [P. 189 Correcting the Misalignment of Printing and Cutting with Crop Marks \(Separate Test for Printing/Cutting with Crop Marks\)](#)

Starting Output with Crop Marks

⚠ WARNING

Never touch the print-head carriage while output is in progress.

The print-head carriage moves at high speed. Coming into contact with the moving carriage may cause injury.

⚠ CAUTION

Do not touch the dancer roller needlessly.

The media take-up unit and feeder may move suddenly, which may result in injury.

MEMO

Prepare just the printing data, do not include the cutting data. Use your software RIP to configure the settings to print with crop marks. For information on how to make the settings, refer to the documentation for the software RIP you are using.

Procedure

1. Shake the pouch trays once per week.

Shake a pouch tray 50 times (for approximately 20 seconds), and then reinsert it. The precipitation of the ingredients in the ink disables printing in normal color. So that the ink mixes well, shake the pouch tray horizontally with a stroke length of around 5 cm (2 in.) from each end of the tray.

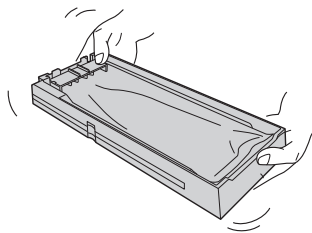

IMPORTANT

- Do not remove the ink pouches. Shake the entire pouch tray. Removing the ink pouches may lead to the ink leaking.
- Before shaking, wipe off any ink from around the mouth of the ink pouch. If you do not wipe off the ink, it may splatter when you shake the pouch tray.
- When you have finished mixing the ink, reinsert the pouch tray immediately. Taking time to reattach the ink cartridge will adversely affect the ink path.

2. Close the front cover.

3. Make sure [Output possible.] is displayed at the top of the operation panel.

4. Send the output data from the computer.

For information on how to create the output data, refer to the documentation for the software RIP.

MEMO

- When you send the output data, [Ink circulation in progress.] or [Normal cleaning in progress.] may be displayed on the screen. These indicate the preparation operations performed before output. Output will begin after the time displayed on the screen elapses.

- If [Heater warm up in progress. Please wait.] is displayed, wait until the set temperature is reached.
- The data being output can be viewed as an image. Tap  shown in the following figure to switch to the remaining ink screen. Tap this icon again to return to the screen for checking the data being output. However, this functionality is limited to software RIPs that support the display of the output data image (thumbnail).

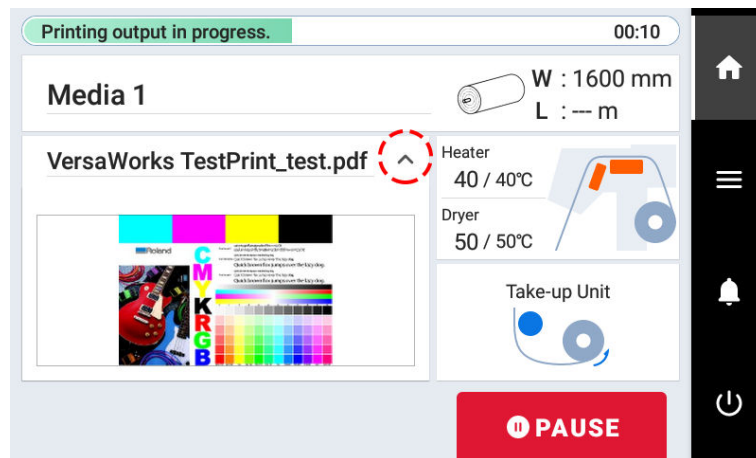

IMPORTANT

Output Is Not Possible in These Situations

- The machine does not run when a cover (front, left, or right) is open.
- Data from the computer is not accepted when [Load media.] is displayed.
- Output does not start while [Heater warm up in progress. Please wait.] is displayed.
- On menu screens where [Menu operation in progress: Press [Home] to enable output.] is displayed, output doesn't start even when data is sent from the computer. When you return to a menu item where output is possible or tap  to return to the home screen, output starts.

Points that must be observed

- Never open a cover (front, left, or right) while output is in progress. Doing so interrupts printing.
- When you are performing printing, clamp the edges of the media with the media clamps. Otherwise, the edges of the media may warp and catch on the print heads.
- During output, do not touch the media. Doing so may obstruct the media feed or cause the media to rub against the print heads, which may result in a paper jam or damage to the heads.
- Keep the loading lever raised when the machine is not in use.

When not using the machine, remove any media and store it in a suitable environment.

- If the machine is left with the media loaded, the media may be damaged, which may adversely affect printing. When not using the machine, remove any media and store it in a suitable environment.

RELATED LINKS

- [P. 164 Changing the Print Heater Temperature](#)
- [P. 166 Changing the Dryer Temperature](#)
- [P. 171 Switching Off the Print Heater and Dryer Together](#)

Preparations for Cutting Output

After printing crop marks and performing post-processing such as laminating, load the media again. Use this section to check the settings required for cutting output.

Step 1: Loading Media with Crop Marks

Procedure

1. Load the media on which crop marks have been printed.

Place the front left and right crop marks so they are straight and aligned with the blade protector (A).

IMPORTANT

Ensure that the crop marks are not angled by more than 5 degrees. Crop marks cannot be read at higher angles.

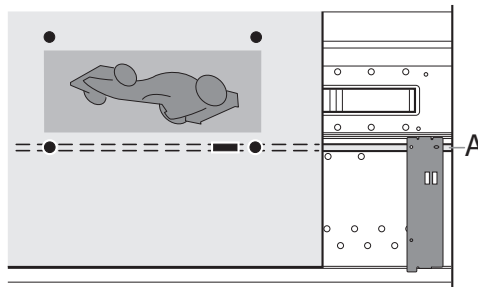

2. Finish the media setup and check that the home screen is displayed.

This completes the setup of the media with crop marks. Proceed to [Step 1: Switching Off the Print Heater and Dryer \(P. 122\)](#).

RELATED LINKS

- [P. 30 Setup of New Media](#)
- [P. 67 Setup of Registered Media](#)

Step 2: Switching Off the Print Heater and Dryer

Procedure

1. Tap  to display the home screen.

2. Tap the following part.

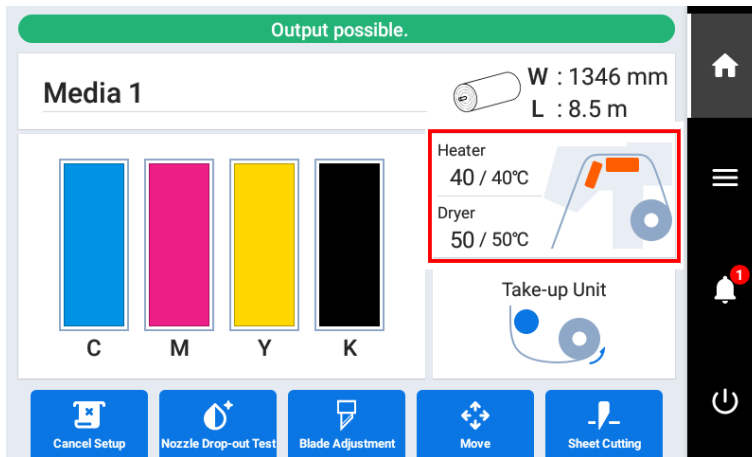

3. Tap [Heater Power] to turn it off as shown below.

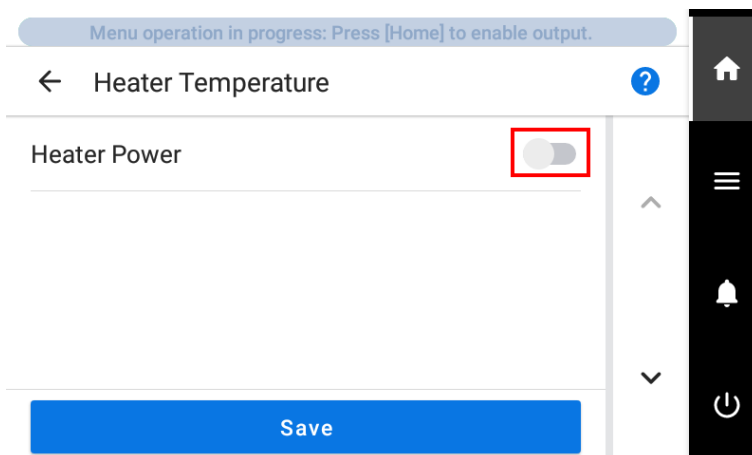



4. Tap [Save] to confirm your entry.
The [Print Heater] and [Dryer] settings turn off.

5. Tap  to go back to the original screen.

Step 3: Preventing Pulling of the Media with Undue Force

Procedure

1. Tap  .
2. Tap [Preferences]>[Prefeeding at Output].
3. Select [Enable].
4. Press [Save] to confirm your entry.
5. Tap  to go back to the original screen.

Starting Cutting Output

⚠ WARNING

Never touch the print-head carriage while output is in progress.

The print-head carriage moves at high speed. Coming into contact with the moving carriage may cause injury.

⚠ CAUTION

Do not touch the dancer roller needlessly.

The media take-up unit and feeder may move suddenly, which may result in injury.

MEMO

Prepare just the cutting data, do not include the printing data.

Procedure

1. Close the front cover.

2. Tap  to display the home screen.

3. Make sure [Output possible.] is displayed at the top of the operation panel.

4. Send the output data from the computer.

For information on how to create the output data, refer to the documentation for the software RIP.

IMPORTANT

Output Is Not Possible in These Situations

- The machine does not run when a cover (front, left, or right) is open.
- Data from the computer is not accepted when [Load media.] is displayed.
- On menu screens where [Menu operation in progress: Press [Home] to enable output.] is displayed, output doesn't start even when data is sent from the computer. When you return to a menu item where output is possible or tap  to return to the home screen, output starts.

Points that must be observed

- Never open a cover (front, left, or right) while output is in progress. Doing so interrupts printing.
- During output, do not touch the media. Doing so may obstruct the media feed or cause the media to rub against the print heads, which may result in a paper jam or damage to the heads.
- Keep the loading lever raised when the machine is not in use.

When not using the machine, remove any media and store it in a suitable environment.

- If the machine is left with the media loaded, the media may be damaged, which may adversely affect printing. When not using the machine, remove any media and store it in a suitable environment.

Optimizing Quality and Efficiency

Optimizing the Output Quality

Using the Correction Functions.....	148
Automatically Making Required Adjustments	148
Manual Adjustment: Reducing Horizontal Bands (Feed Correction Function)	149
Manual Adjustment: Adjusting the Misalignment of the Ink Landing Position (Media Gap Adjustment).....	151
Configuring Settings to Match the Properties of the Media	153
Changing the Print Head Height	153
Using Hard-to-Dry Media	155
Using Media That Wrinkles Easily/Does Not Move Smoothly.....	156
Using Sticky Media	157
Setting the Take-up Unit	158
Preventing Ink Discharge Issues	160
Preventing Soiling of the Media, Dot Drop-out, and Dot Displacement.....	160
Preventing Misaligned Media.....	161
Use Middle Pinch Rollers When Pulling Back or Feeding Media	161
Adjusting the Ink-drying Method	162
What Is the Media Heating System?	162
Changing the Print Heater Temperature.....	164
Changing the Dryer Temperature	166
Hints and Tips for Temperature Control	168
Setting the Temperature during Standby.....	169
Drying the Trailing Edge of the Printing Area on the Dryer	170
Switching Off the Print Heater and Dryer Together.....	171
Accurately Adjusting the Cutting Settings.....	173
Fine-tuning the Cutting Conditions.....	173
Accurately Adjusting the Cutting-in Amount.....	175
Performing Distance Correction during Cutting	177
Cutting to Make It Possible to Cut Corners Attractively (Over Cut)	178
Prioritizing the Cutting Settings of This Machine over the Software RIP Settings....	180
Accurately Adjusting the Settings for Printing and Cutting	181
Correcting the Misalignment of Printing and Cutting	181
Correcting the Misalignment of the Printing and Cutting Positions during Cutting ..	184
Accurately Adjusting the Settings for Cutting with Crop Marks	186
Correcting the Misalignment of Printing and Cutting with Crop Marks (Concur- rent Test for Printing and Cutting with Crop Marks).....	186
Correcting the Misalignment of Printing and Cutting with Crop Marks (Sepa- rate Test for Printing/Cutting with Crop Marks)	189
Correcting the Reading Sensor	193

Using the Correction Functions

To optimize the output quality, it is effective to use some correction functions.

Automatically Making Required Adjustments

To optimize the output quality, corrections must match the media and printing conditions.

Depending on the printing conditions, the ink landing position may be misaligned and the movement distance may change subtly during media feeding. Automatically correct these issues to match the media.

First, print a test pattern. Then read this pattern with the multi sensor and automatically enter the correction values.

Executing automatic correction prints a test pattern, reads this pattern, and enters the correction values for the following operations.

- Multi sensor adjustment (adjusting to the optimal condition the sensor used in correction)
- Media gap adjustment (correcting the ink landing position)
- Feed correction (to reduce horizontal bands)

Procedure

1. Load the media.

2. Close the front cover.

3. Tap .

4. Tap [Media Settings]>[Printing Settings]>[Batch Automatic Correction].

5. Tap [Execute].

Test patterns are printed and correction values are entered for the following operations.

- Multi Sensor Adjustment
- Feed Correction
- Media Gap Adjustment

6. Tap [OK] when the completion screen appears.

7. Perform the operations shown below according to the [Result].

- If [Successful] is displayed on the operation panel, tap  to go back to the original screen.
- If [Failed] is displayed on the operation panel, carry out manual adjustment.

RELATED LINKS

- [P. 149 Manual Adjustment: Reducing Horizontal Bands \(Feed Correction Function\)](#)
- [P. 151 Manual Adjustment: Adjusting the Misalignment of the Ink Landing Position \(Media Gap Adjustment\)](#)



Manual Adjustment: Reducing Horizontal Bands (Feed Correction Function)

Perform corrections to make the band-shaped "stripes" on the printed surface less noticeable.

The band-shaped "stripes" are called "horizontal bands" or "banding." Horizontal bands are caused by the subtle changes in the movement distance that occur when feeding the media depending on the media's thickness and the temperature of the dryer. We recommend that you make corrections to match the media you are using and the set temperature of the dryer.

First, print a test pattern, and then determine and enter the correction value. After entering the correction value, print a test pattern again and check the correction results. Repeat the process of printing a test pattern and entering a correction value several times to find the optimal correction value.



Procedure

1. Load the media.
2. Close the front cover.
3. Tap .
4. Tap [Media Settings]>[Printing Settings]>[Feed Correction].
5. Select [Detailed Correction (Manual)] and tap [Next].
6. Tap [Execute] next to [Printing Test].
Printing of the test pattern starts.
7. Check the printed test pattern, and then tap  or  to enter the correction value.

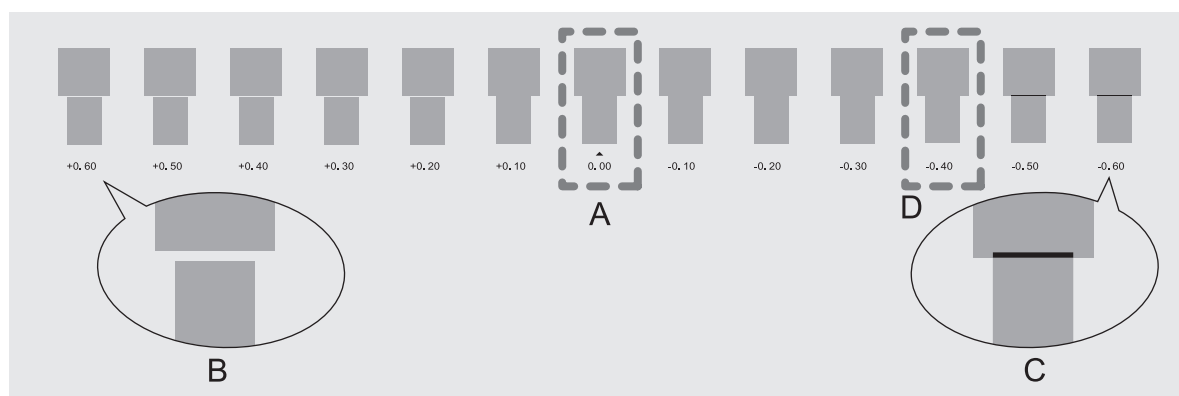
The current correction value (A) is that of the figure indicated by "▲." Select the value to make the gap (B) and overlap (C) between the upper/lower squares smallest. In the case of the following figure, select "-0.40" (D). When you cannot choose between two sequential numbers, specify a value that is between them.



MEMO

- If the test pattern is difficult to see, tap  or  next to [Media Feed] to move the media to a position where it is easier to see.

- If you want to hold the media to check the test pattern, tap [Execute] next to [Sheet Cutting] to separate the media.

8. Tap [Save].

The entered correction value is saved.

9. Tap [Execute] next to [Printing Test].

The test pattern is printed again.

10. Check the test pattern to see whether the correction was successful.

Check that the gap and overlap are the smallest for the figure indicated by "▲" (that is, the current correction value). If the gap and overlap are smaller for another figure, set the correction value again.

11. When you have successfully performed the correction, tap  to go back to the original screen.

Manual Adjustment: Adjusting the Misalignment of the Ink Landing Position (Media Gap Adjustment)

This adjusts the landing position of the ink discharged from the print heads. The landing position varies according to the print head height and the thickness of the media, so we recommend that you make corrections to match the media you are using.

First, print a test pattern, and then determine and enter the correction value. After entering the correction value, print a test pattern again and check the correction results.

This adjustment must be performed in the following cases.

- When using this machine for the first time
- When changing the media to use
- When you have changed the print-head height

Procedure

1. Load the media.



2. Close the front cover.

3. Tap .

4. Tap [Media Settings]>[Printing Settings]>[Media Gap Adjustment].

5. Select [Detailed Correction (Manual)] and tap [Next].



6. Tap [Execute] next to [Printing Test].
Printing of the test pattern starts.

7. Check the printed test pattern, and then tap  or  to enter the No. 1: H1 to H2 and No. 2: H1 to H2 correction values.

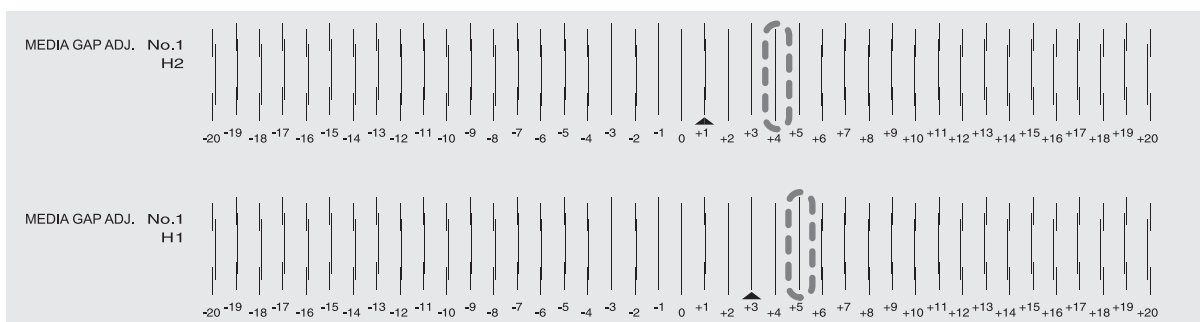
Select the value that gives the least misalignment between the two lines. In the case of the following figure, select "+5" for H1 and "+4" for H2. When you cannot choose between two sequential numbers, select a value that is between them (you can set correction values in units of "0.5").



MEMO

- If the test pattern is difficult to see, tap  or  next to [Media Feed] to move the media to a position where it is easier to see.

- If you want to hold the media to check the test pattern, tap [Execute] next to [Sheet Cutting] to separate the media.

8. Tap [Save].

The entered correction values are saved.

9. Tap [Execute] next to [Printing Test].

The test pattern is printed again.

10. Check the test pattern to see whether the correction was successful.

For all the correction values, check that the misalignment is minimized for the two vertical lines indicated by "▲" (that is, the current correction value). If the misalignment is smaller for another set of vertical lines, set the correction value again.

11. When you have successfully performed the correction, tap  to go back to the original screen.

Configuring Settings to Match the Properties of the Media

Changing the Print Head Height

This adjusts the print head height to prevent media that is wrinkled or comes loose from the platen from contacting the print heads.

You can select the print head height from [Low], [Medium], and [High]. Printing quality when the print head height is set to [Medium] or [High] may be coarser or otherwise lower than when set to [Low].

Procedure

1. Load the media.

2. Tap .

3. Tap [Media Settings]>[Printing Settings]>[Print Head Height].

4. Tap [Change].

The print heads move to a position where they can be operated.

5. Open the front cover.

6. Move the height-adjustment lever to adjust the print head height.

When you change the position of the height-adjustment lever, the display screen will change.

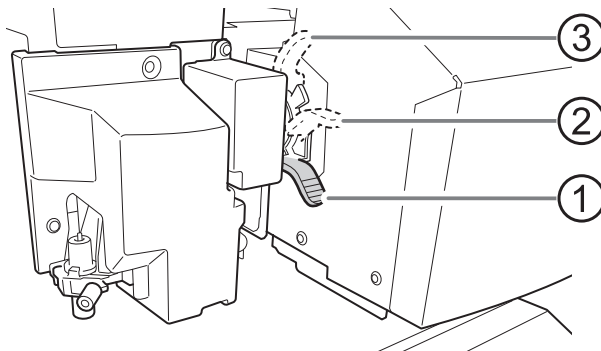

Position	Operation panel display	Description
①	[Low]	Normally set the height-adjustment lever to [Low].
②	[Medium]	For media that is wrinkled or comes loose from the platen during printing, set the height-adjustment lever to [Medium].
③	[High]	For media that is wrinkled or comes loose from the platen during printing even when the height-adjustment lever is set to [Medium], set the lever to [High].

IMPORTANT

The printing quality degrades as the distance between the media and the print heads increases. Do not move the height-adjustment lever to [Medium] or [High] needlessly.

7. Close the front cover.

8. Tap [OK].
The print heads move to their original position.

9. Tap  to go back to the original screen.

MEMO

- Default setting: [Low]
- If degradation of printing quality occurs after raising the print head height, refer to the following information and try optimizing the quality.





RELATED LINKS

- [P. 148 Automatically Making Required Adjustments](#)
- [P. 151 Manual Adjustment: Adjusting the Misalignment of the Ink Landing Position \(Media Gap Adjustment\)](#)
- [P. 160 Preventing Soiling of the Media, Dot Drop-out, and Dot Displacement](#)

Using Hard-to-Dry Media

This setting is used to extend the drying time when the ink dries poorly even if the dryer is used.

Procedure

1. Load the media.
2. Tap .
3. Tap [Media Settings]>[Other Media Settings]>[Drying Time Per Scan].
4. Tap  or  to enter the value.
Larger values cause the media to move more slowly, extending the drying time accordingly.
5. Tap [Save] to confirm your entry.
6. Tap  to go back to the original screen.

MEMO

- Default setting: [Off]
- Depending on the software RIP you are using, you can also make this setting in the software RIP. When you have made the setting in the software RIP, the printer's setting is ignored.

RELATED LINKS

- [P. 162 Adjusting the Ink-drying Method](#)

Using Media That Wrinkles Easily/Does Not Move Smoothly

The platen uses suction to grip the media and keep it stable. The suction force can be adjusted corresponding to the nature and condition of the media.

Procedure

1. Load the media.

2. Tap .

3. Tap [Media Settings]>[Other Media Settings]>[Media Suction Force].

4. Tap  or  to enter the value.

0 to 100%	When the media is flimsy and cannot move smoothly, decreasing this value (reducing the suction force) may correct the problem.
Auto	The suction force is automatically adjusted to the optimal level for the media width

5. Tap [Save] to confirm your entry.

6. Tap  to go back to the original screen.

MEMO



- Default setting: [Auto]
- Depending on the software RIP you are using, you can also make this setting in the software RIP. When you have made the setting in the software RIP, the machine's setting is ignored.

Using Sticky Media

This setting is used to peel off the media before starting printing when using media that sticks easily to the platen. This setting is effective to prevent media jams.

Note, however, that peeling off the media may cause unstable media feed. Leave this menu item set to **[Disable]** unless you specifically need to change it.

Procedure

1. Load the media.
2. Tap .
3. Tap [Media Settings]>[Other Media Settings]>[Media Sticking Prevention].
4. Select [Enable].
5. Tap [Save] to confirm your entry.
6. Tap  to go back to the original screen.

MEMO

- Default setting: **[Disable]**

Setting the Take-up Unit

When using a take-up unit, make sure the following settings match the take-up method and output method of the actual media.

The settings will have to be changed from the defaults when:

- Just printing on weak media and not cutting.
- Taking-up the media with inward curl.

Procedure

1. Tap .

2. Tap [Preferences]>[Take-up].

3. Tap [Take-up Method].

4. Select the setting from those shown below and tap [Save].

[Loose Winding]	The media is taken up with some slack. This is suited to PVC and other such stiff or slippery media.
[Tension Winding]	The media is stretched and taken up. This is suited to tarpaulin and other such weak media and media that does not slip easily.

IMPORTANT

When the output data includes the cutting operation, this setting is ignored, and no take-up is performed until the output of the piece of data is finished.

MEMO

- Default setting: [Loose Winding]

5. Tap [Take-up Direction].

6. Select the setting from those shown below and tap [Save].

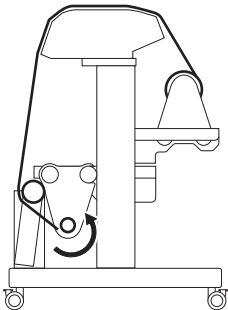
[Forward]	The media is taken up onto the paper tube with the printed surface on the outside. 
-----------	---

[Backward]

The media is taken up onto the paper tube with the printed surface on the inside.

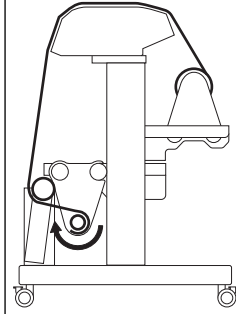

MEMO

- Default setting: [Forward]

7. Tap  to go back to the original screen.

Preventing Ink Discharge Issues

Preventing Soiling of the Media, Dot Drop-out, and Dot Displacement

Removing the ink buildup on the print head surface before or during printing prevents soiling of the media, dot drop-out, and dot displacement.

In the following cases, ink tends to collect on the surface of the print heads.

- When you use media prone to static electricity buildup.
- When the ambient temperature is low.
- When the print-head height is set to [High].

Procedure

1. Tap .

2. Tap [Preferences]>[Cleaning during Printing].

3. Tap a setting to select it.

If you select [Periodically (Job Priority)] or [Periodically (Time Priority)], set the time and tap [OK].

[No Cleaning]	Automatic cleaning is not performed.
[Every Page]	Automatic cleaning is performed each time prior to the start of printing.
[Periodically (Job Priority)]	Automatic cleaning is performed when the cumulative printing time reaches the value you set here. However, if this time is reached during printing, automatic cleaning is performed before the next printing operation starts. Because printing is not paused, uneven color issues due to paused operation do not occur.
[Periodically (Time Priority)]	Automatic cleaning is performed when the cumulative printing time reaches the value you set here. When this time is reached during printing, printing pauses and so colors may be uneven.

4. Tap [Save] to confirm your entry.

5. Tap  to go back to the original screen.

MEMO

- Default setting: [No Cleaning]
- Settings other than [No Cleaning] result in longer printing times.

Preventing Misaligned Media

Use Middle Pinch Rollers When Pulling Back or Feeding Media

Set the setting that causes the middle pinch rollers to go up automatically during pullback printing or printing and cutting to **[Disable]**. Holding down media that is not straight or comes loose is effective in preventing misalignment during printing and cutting.

[Middle Pinch Auto Raise/Lower] is a function that causes the middle pinch rollers to automatically rise when media is pulled back, performs overprinting and cutting while they are raised. However, if you are performing lengthy printing or using non-resilient media, the media will be skewed or will come loose, which may have an effect on the output quality.

If you set **[Middle Pinch Auto Raise/Lower]** to **[Disable]**, the middle pinch rollers will press down on the media while moving, thus preventing skewing or coming loose. However, because the middle pinch rollers are pressed against the printed surface, it is easier for the rollers to leave a trace on the printed surface. Before pulling back the media, make sure to dry it thoroughly.

Procedure

1. Load the media.

2. Tap .

3. Tap **[Media Settings]>[Other Media Settings]>[Middle Pinch Auto Raise/Lower]**.

4. Select **[Disable]**.

The middle pinch rollers will lower during media feeding and pullback, pressing down on the media while moving.

5. Tap **[Save]** to confirm your entry.

6. Tap  to go back to the original screen.

MEMO

- Default setting: **[Enable]**

RELATED LINKS

- [P. 162 Adjusting the Ink-drying Method](#)

Adjusting the Ink-drying Method

What Is the Media Heating System?

This machine is equipped with a media heating system that warms the media. You use this mainly to improve ink adhesion and dry the ink. You can adjust the temperature settings to match the type of media and the printing speed.

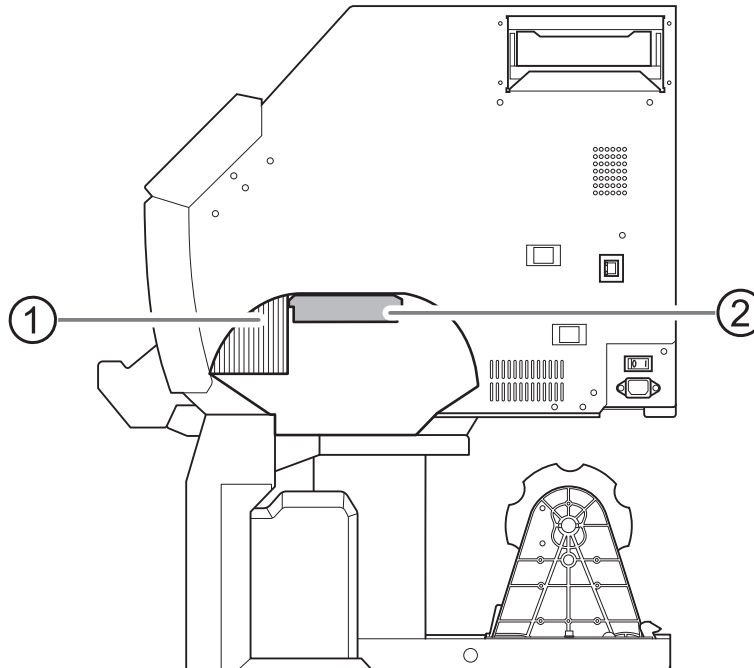

①	Dryer	This is used to speed up the drying of the ink.
②	Print heater	This heater is used mainly to improve ink adhesion.

⚠ WARNING

High Temperature

The platen and dryer become hot. Exercise caution to avoid burns.

⚠ WARNING

Remove any loaded media or switch off the sub power when printing is not being performed.

The continued application of heat at a single location may cause the release of toxic gases from the media or pose a fire hazard.

⚠ WARNING

Never use media that cannot withstand heat.

Doing so may degrade the media, or may result in fire or the release of toxic gases.

⚠ WARNING

Never use the platen or dryer for any purpose for which they are not intended, such as to dry clothing.

Doing so may cause overheating, resulting in fire or accident.

IMPORTANT

Use the machine in an environment with an ambient temperature of 20 to 32 °C (68 to 90 °F).

If the machine is used at an ambient temperature lower than 20 °C (68 °F), then depending on the type or width of the media, wrinkling or temperature-caused unevenness may occur. If this happens, try lowering the temperature of the media heating system by about 2 °C. To obtain stable printing results, however, use the machine in an environment with an ambient temperature of 20 °C to 32 °C (68 °F to 89.6 °F).

Changing the Print Heater Temperature

Setting the temperature of the print heater appropriately improves ink adhesion and inhibits smudging. An applicable application is changing the set temperature of registered media.

- With the default settings, the temperature rises to the [Standby Heater Temperature] when the power turns on. On completion of media setup, the temperature rises to the set value.
- Depending on the usage environment, the temperature of the dryer may become higher than the set temperature, but this does not represent a problem.
- Temperature settings are not possible when [Heater Power] accessed from [Media Settings]>[Heater Settings]>[Heater Temperature] is off.

Procedure

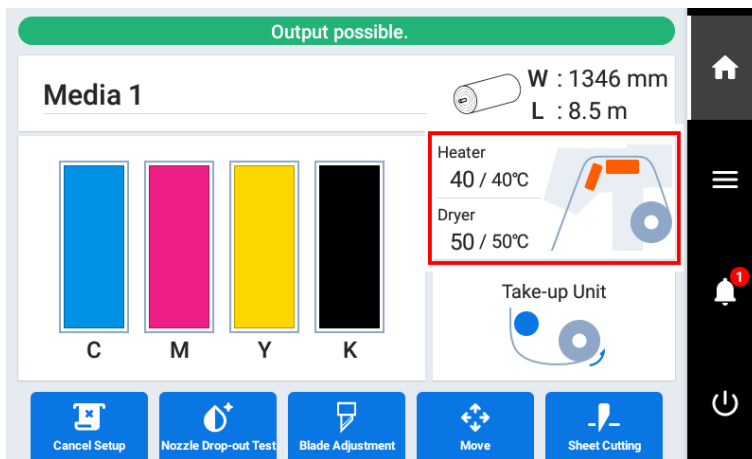

1. Load the media.
2. Tap the following location on the home screen.

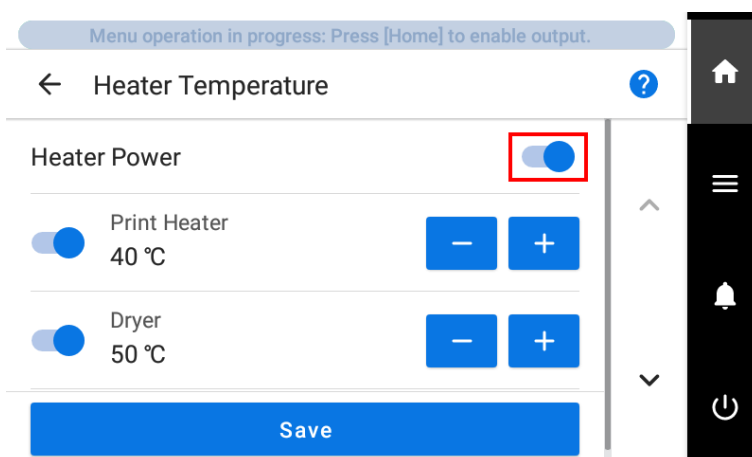

The [Heater Temperature] screen appears.

3. Check that the [Heater Power] check box is selected.



4. Tap  or  to set the [Print Heater] temperature.

If the ink forms lumps or smudges, raise the temperature. Note, however, that a temperature that is too high may degrade the media or cause it to wrinkle.

5. Tap [Save] to confirm your entry.

6. Tap  to go back to the original screen.

MEMO

- Default setting: 40°C (104°F)
- You can also make this setting in the software RIP. When you have made the setting in the software RIP, the software RIP's setting is used.

RELATED LINKS

- [P. 51 Configure settings to match the media.](#)

Changing the Dryer Temperature

Setting the temperature of the dryer appropriately makes the ink dry fast. An applicable application is changing the set temperature of registered media.

- With the default settings, the temperature rises to the [Standby Heater Temperature] when the power turns on. On completion of media setup, the temperature rises to the set value.
- Depending on the usage environment, the temperature of the dryer may become higher than the set temperature, but this does not represent a problem.
- Temperature settings are not possible when [Heater Power] accessed from [Media Settings]>[Heater Settings]>[Heater Temperature] is off.

Procedure

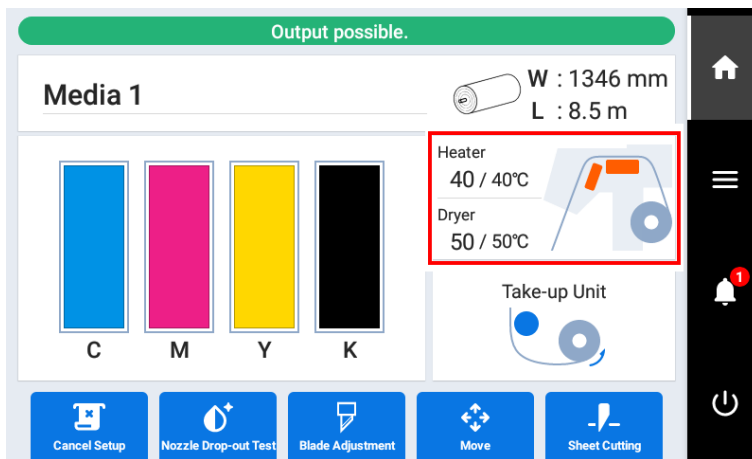

1. Load the media.
2. Tap the following location on the home screen.

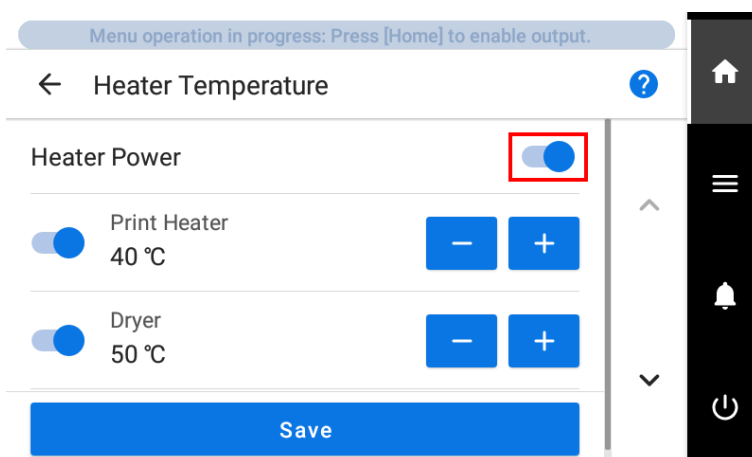

The [Heater Temperature] screen appears.

3. Check that the [Heater Power] check box is selected.



4. Tap  or  to set the [Dryer] temperature.

When ink drying is poor, set the temperature to a higher value. Note, however, that a temperature that is too high may degrade the media or cause it to wrinkle.

5. Tap [Save] to confirm your entry.

6. Tap  to go back to the original screen.

MEMO

- Default setting: 50°C (122°F)
- You can also make this setting in the software RIP. When you have made the setting in the software RIP, the software RIP's setting is used.

RELATED LINKS

- [P. 51 Configure settings to match the media.](#)

Hints and Tips for Temperature Control

The optimal temperature for the media heating system varies according to such factors as the type of media and the settings of the software RIP.

Relationship between the quality settings of the software RIP and temperature

If smudging or poor drying occur even after raising the temperature, try setting the printing quality of the software RIP to higher image quality. Conversely, if you want to use a faster print quality, raise the temperature.

Amount of ink

When you change the amount of ink using the settings for your software RIP, adjusting this may yield better results. If problems such as smudging persist even after raising the temperature, try reducing the amount of ink.

Other points to remember

When recommended settings for temperature, printing quality, and other values are given for your media, use the suggested settings.

Setting the Temperature during Standby

Standby: State in which the main power and the sub power are switched on and the media setup is not complete.

Procedure

1. Tap .
2. Tap [Preferences]>[Standby Heater Temperature].

3. Tap  or  to set the temperature.

When this is set to  (off), the media heating system is switched off during standby.

4. Tap [Save] to confirm your entry.
5. Tap  to go back to the original screen.



MEMO



- Default setting: 30°C



Drying the Trailing Edge of the Printing Area on the Dryer

To dry the ink thoroughly, configure the settings so that the media is fed until the trailing edge of the printed area is put on the dryer after the printing is finished.

Procedure

1. Load the media.
2. Tap .
3. Tap [Media Settings]>[Heater Settings]>[Dry After Printing].
4. Tap  to turn it on.

 (On)	Media feed is performed until the trailing edge of the printing area is positioned on the dryer.
 (Off)	Media feed stops when printing ends. This means that the trailing edge of the printing area is not fed to the dryer unless you continue with a subsequent printing operation.

5. Tap  or  to set the drying time for [Drying Time (Printing Only)] or [Drying Time (Printing & Cutting)].

MEMO

Drying Time

- The next operation is not started until the set time elapses.
- Tap [Skip] during drying to finish the drying time and start the next operation.
- When the drying time has been set in the software RIP, priority is given to the software RIP's setting.
- If [Drying Time] is set to a value other than [0 min.] and [Drying Feed] is off, the machine waits for the set time at the print-end position before starting the next operation.

6. Tap [Save] to confirm your entry.

7. Tap  to go back to the original screen.

MEMO

Default setting:

- [Drying Feed (Printing Only)]: Off
- [Drying Feed (Printing & Cutting)]: Off
- [Drying Time (Printing Only)]: [0 min.]
- [Drying Time (Printing & Cutting)]: [0 min.]

Switching Off the Print Heater and Dryer Together

This setting is useful when you want to switch off the media heating system collectively, such as when performing only cutting. Turning off [Heater Power] under [Media Settings]>[Heater Settings]>[Heater Temperature] will make it impossible to set the temperature of the print heater and dryer.

Procedure

1. Load the media.
2. Tap the following location on the home screen.

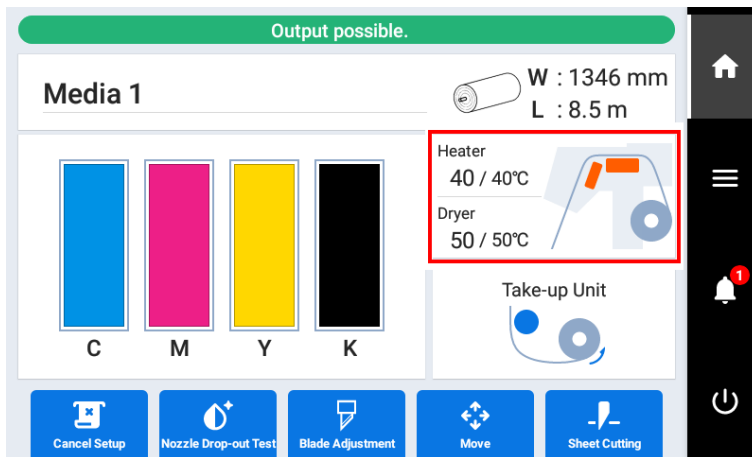

The [Heater Temperature] screen appears.

3. Tap  next to [Heater Power] to turn it off.

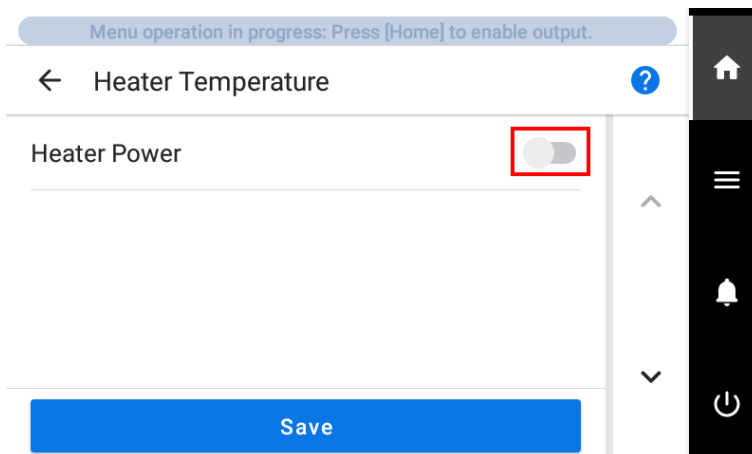

The settings for the print heater and dryer are turned off.

4. Tap [Save] to confirm your entry.
5. Tap  to go back to the original screen.

MEMO

- Default setting: On

IMPORTANT

When this is set to off, the heater will not turn on even if the heater temperature is set in the included software RIP.

Accurately Adjusting the Cutting Settings



Fine-tuning the Cutting Conditions

You can accurately set items such as the blade force, movement speed, and blade offset to match the nature of the media and the shape to cut. First, perform a cutting test, and then determine and enter the setting values. After entering the setting values, perform a cutting test again and check the results. Repeat the process of performing a cutting test and making the settings several times to find the optimal setting values.

Procedure

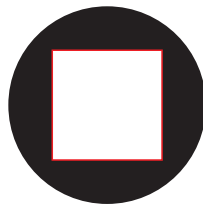
1. Load the media.
2. Close the front cover.
3. Tap  [Blade Adjustment] on the home screen.
4. Tap [Execute] next to [Cutting Test].
The test pattern is cut.
5. Check the results of the cutting test.
If the results are difficult to see, [Execute] [Sheet Cutting], separate the media, and then hold it to check the results.



Check item	Result		Setting item	Adjustment
Check the shape.	The cut shape is distorted.		[Cutting Speed]	Reduce
Peel off the circle.	The square also peels off.		[Blade Force]	Increase
	Some uncut areas remain.		[Cutting Speed]	Reduce
Peel off the square.	The blade leaves faint traces on the backing paper.		[Blade Force]	No change
	The blade trace is indistinct.			Increase
	The blade trace is too deep and cuts into the backing paper.			Reduce
Check the shape of the square you have peeled off.		The corners are not rounded and do not have "horns."	[Blade Offset]	No change
		The corners are rounded.		Increase
		The corners have "horns."		Reduce

6. Tap  or  to change the settings.

Display screen (cutting conditions)	Setting details	Default settings
[Blade Force]	Set the force (pressure) of the blade.	50 gf
[Cutting Speed]	Set the speed of cutting.	30 cm/s
[Blade Offset]	Set the blade offset. Enter the listed offset value for the blade. The offset value for the included blade is 0.250 mm (9.8 mil).	0.250 mm (0.010 in.)
[Rise Movement Speed]	Set the blade's up speed during cutting (the speed at which the blade travels when it moves to the next cutting line after cutting one cutting line). If the media comes loose during no-load feed and the blade damages the surface of the media, reduce the speed.	30 cm/s

7. Tap [Save] to confirm your entry.

8. Tap  to go back to the original screen.

Accurately Adjusting the Cutting-in Amount

When you want to perform accurate and fine adjustment of the cutting-in amount, such as when cutting media with thin backing paper, you can obtain good results by adjusting the amount of blade extension. Turn the cap portion of the blade holder to adjust the amount of blade extension. Each indicator tick corresponds to 0.1 mm (3.9 mil), and adjustment for 0.5 mm (19.7 mil) can be made by rotating the cap one full turn.

Note that making the amount of blade extension too small may cause the tip of the blade holder cap to touch the printed surface, soiling and damaging it. It is important to be especially careful about this when you are using media that has poor ink-adhesion properties.

The amount of blade extension (A) is 0 mm (0 in.) at minimum and 2.5 mm (98.42 mil) (C) at maximum.

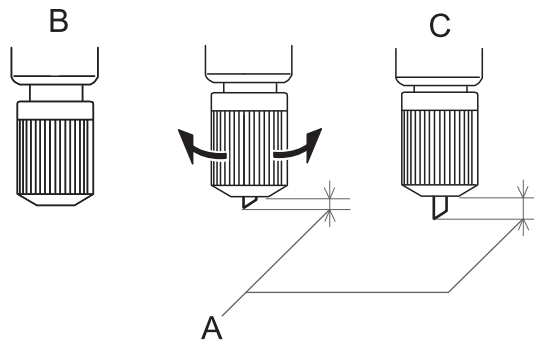

Rough Estimate for the Amount of Blade Extension (When Creating a Sticker)

Set the amount of blade extension (A) to an amount that is the sum of the thickness of the material portion (B) and half (D) the thickness of the backing paper (C).

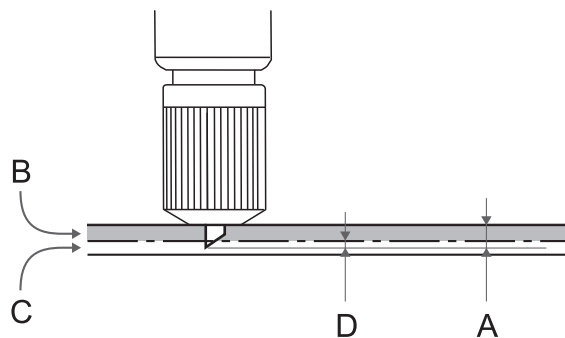

Rough Estimate for the Amount of Blade Extension (When Cutting Perforated Lines)

Set the amount of blade extension (A) so that when the blade pierces the media (B), the blade tip extends slightly.

For information about the output settings for cutting perforated lines, refer to the documentation for VersaWorks.

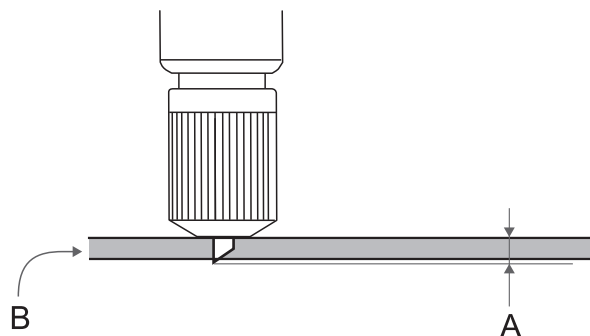

IMPORTANT

Pushing the blade out too far will damage the blade and blade protector and hasten their deterioration, so exercise caution.

Performing Distance Correction during Cutting

This correction is performed when you want to accurately align the lengths of cut lines when cutting. This setting is applied to both cutting only and printing and cutting.

The movement distance of the media changes subtly depending on the media's thickness. This means that the length of a line when cut may differ from the length setting in the data.

Procedure

1. Load the media.

2. Tap .

3. Tap [Media Settings]>[Cutting Settings]>[Cutting Distance Correction].

4. Tap  or  to change the correction values.

Setting item	Setting details	Default settings
[Correction Value (Feed)]	(correction value of media feed direction)	0.00%
[Correction Value (Scan)]	Correction value of the print head movement direction	0.00%

5. Tap [Save] to confirm your entry.

6. Tap  to go back to the original screen.



Cutting to Make It Possible to Cut Corners Attractively (Over Cut)

Cutting the corners of the border of the cutting line slightly longer makes it possible to cut the corners attractively.

This is effective when using laminated or thick media, or non-resilient media. It also has the effect of making stickers easier to peel off.



Procedure

1. Load the media.
2. Tap .
3. Tap [Media Settings]>[Cutting Settings]>[Over Cut].
4. Tap [Enable].
5. Tap [Save] to confirm your entry.
6. Tap  to go back to the original screen.

MEMO

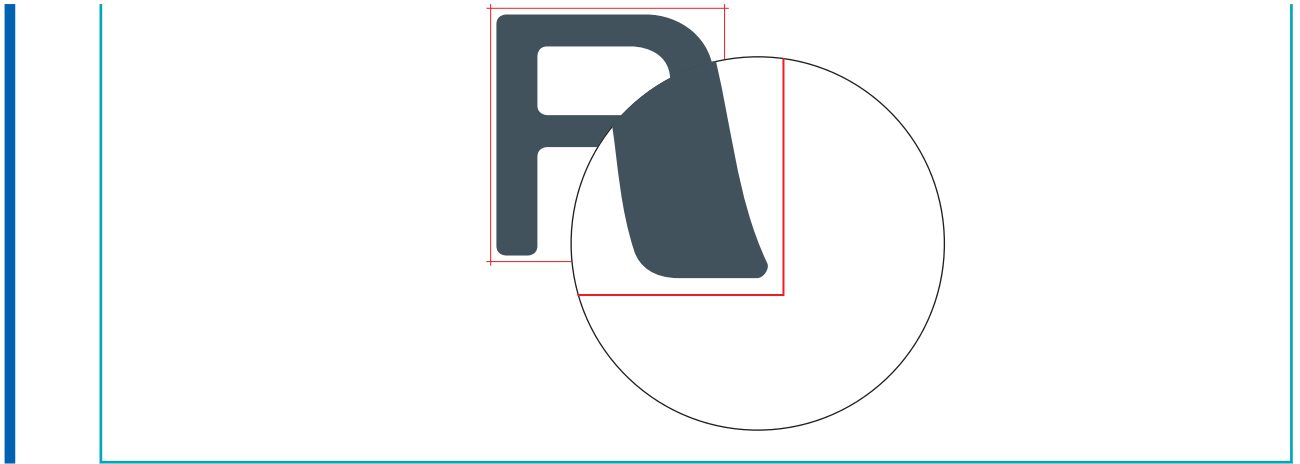

- Default setting: [Disable]
- The cutting start point is not over cut.



Prioritizing the Cutting Settings of This Machine over the Software RIP Settings

This setting is used to prioritize the cutting conditions set on the machine over the software RIP settings. You can also make the settings for the cutting conditions in the software RIP, and normally the software RIP settings are given priority.

Procedure

1. Tap .
2. Tap [Preferences]>[Priority for Cutting Settings].
3. Select [Machine Priority].
4. Tap [Save] to confirm your entry.
5. Tap  to go back to the original screen.

MEMO

- Default setting: [Software RIP Priority]

Accurately Adjusting the Settings for Printing and Cutting

Correcting the Misalignment of Printing and Cutting

This is a correction method performed when printing followed immediately by cutting yields positioning for printing and cutting that is slightly misaligned.

Print alignment marks, perform detection of the printed marks, and then correct the discrepancy. Subtle misalignment between the printing and cutting positions may occur due to the thickness of the media or the head height. We recommend that you make corrections to match the media you are using.

1. Adjust the misalignment of the ink landing position.

Procedure

1. Load the media.

2. Tap .

3. Tap [Media Settings]>[Printing Settings]>[Media Gap Adjustment].

4. Select [Simple Correction (Auto)] and tap [Next].

5. Tap [Execute].

The test pattern is printed and the media gap is adjusted automatically.

6. Tap [OK] when the completion screen appears.

7. Perform the operations shown below according to the [Result].

- If [Successful] is displayed on the operation panel, tap  to go back to the original screen.
- If [Failed] is displayed on the operation panel, manually adjust the media gap.

RELATED LINKS

- [P. 151 Manual Adjustment: Adjusting the Misalignment of the Ink Landing Position \(Media Gap Adjustment\)](#)

2. Correcting the Misalignment of Printing and Cutting

Procedure

1. Tap .
2. Tap [Media Settings]>[Cutting Settings]>[Print & Cut Position Adjustment].
3. Tap [Execute] next to [Printing Test 1 (Misalignment Check)].
Printing Test 1 is printed and cut. The test pattern is printed at each edge of the media.

MEMO

If the media is tilted, the positions at the edges will be misaligned. You can also adjust for misalignments due to the media being tilted by printing the test pattern at each edge.

4. Check the result of Printing Test 1.
Check whether the printing position (shaded part) and the cutting position (red line) are aligned. An example of the printing position and the cutting position being misaligned is shown in the following figure.
[F] indicates the feed direction of the media (the feed direction) and [S] indicates the direction of print head movement (the scan direction).

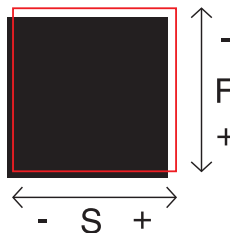



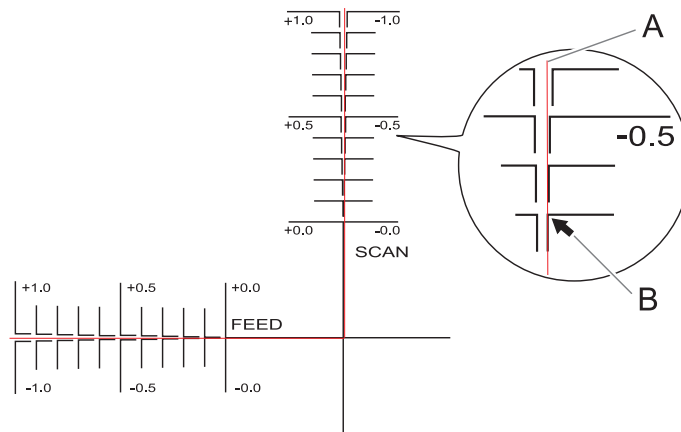

If the printing position and the cutting position are aligned, no corrections are necessary.
If the printing position and the cutting position are not aligned, proceed to the next procedure.

5. Tap [Execute] next to [Printing Test 2 (Correction Values)].
Printing Test 2 is printed and cut.
6. Check the correction values from the Printing Test 2 condition.
The point where the cutting line (A) intersects the correction-value scale (B) is the correction value. In the following figure, the correction value is "-0.3."
Check the media feed direction (the feed direction) and the direction of print head movement (the scan direction).





7. Set the correction values in the feed direction of the media (the feed direction) and the direction of print head movement (the scan direction).

- (1) Tap  or  next to [Correction Value (Feed)] to set the correction value in the feed direction of the media (the feed direction).
- (2) Tap  or  next to [Correction Value (Scan)] to set the correction value in the direction of print head movement (the scan direction).

8. Tap [Save].

The correction values are saved.

9. Tap [Execute] next to [Printing Test 1 (Misalignment Check)].

Printing Test 1 is printed and cut. If the printing and cutting lines are aligned, adjustment is complete. If further adjustment is needed, tap  or  next to [Correction Value (Feed)] and [Correction Value (Scan)] to fine-tune the printing and cutting position, and then [Save] the values.

MEMO

Default settings

- [Correction Value (Feed)] (correction value of the media feed direction): 0.00 mm
- [Correction Value (Scan)] (correction value of the print head movement direction): 0.00 mm

10. Tap  to go back to the original screen.

Correcting the Misalignment of the Printing and Cutting Positions during Cutting

This method pauses a cutting operation to correct the misalignment of the cutting positions (A) when this misalignment is found during cutting after printing. The correction values set here are applied to the media settings currently set up.



If the printing and cutting positions are misaligned, normally adjust the positions while checking a test pattern.

Procedure

1. During cutting, tap [Pause].
The cutting operation is paused.
2. Tap .
3. Tap [Media Settings]>[Cutting Settings]>[Print & Cut Position Adjustment].
4. Determine the correction value for the cutting position.

MEMO

To decide a correction value

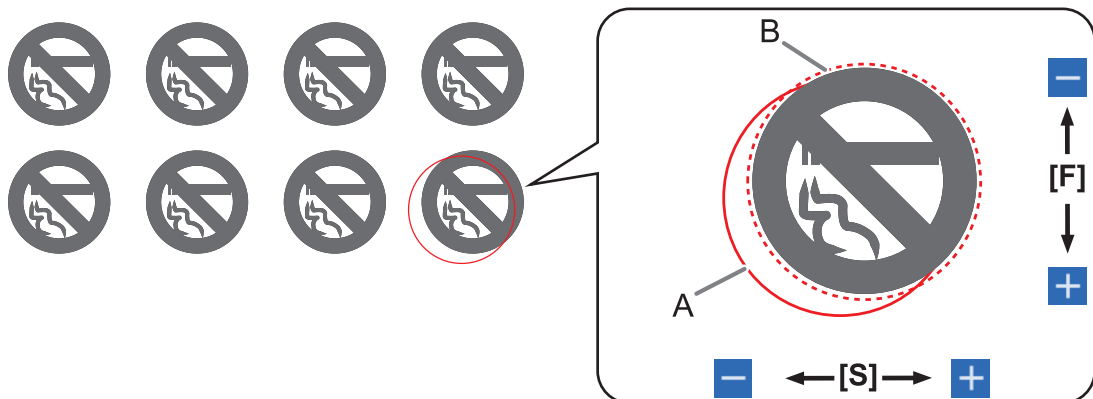

In the following figure, move the solid line (A), representing the current cutting position, to the dashed line (B).





- Media feed direction misaligned in the positive direction

- Move the cutting position in the negative direction.
- Print head movement direction (scan direction) misaligned in the negative direction
- Move the cutting position in the positive direction.

5. Set the correction values in the feed direction of the media (the feed direction) and the direction of print head movement (the scan direction).

(1) Tap  or  next to [Correction Value (Feed)] to set the correction value in the feed direction of the media (the feed direction).

(2) Tap  or  next to [Correction Value (Scan)] to set the correction value in the direction of print head movement (the scan direction).

6. Tap [Save] to confirm your entry.

7. Tap  to go back to the original screen.

8. Tap [Resume] to restart the cutting operation.
Tap [Cancel Output] to cancel the cutting operation.

MEMO

- Default settings
 - [Correction Value (Feed)] (correction value of the media feed direction): 0.00 mm
 - [Correction Value (Scan)] (correction value of the print head movement direction): 0.00 mm

RELATED LINKS

- [P. 181 Correcting the Misalignment of Printing and Cutting](#)

Accurately Adjusting the Settings for Cutting with Crop Marks

Correcting the Misalignment of Printing and Cutting with Crop Marks (Concurrent Test for Printing and Cutting with Crop Marks)

Depending on the composition of the media, the positioning of printing and cutting may be misaligned even when you are using crop marks. Make corrections for misaligned printing and cutting for the media you are using.

In cutting with crop marks, cutting is performed after removing the media after printing. However, with this method, you can make corrections of printing and cutting positions at the same time without removing the media.

1. Adjust the misalignment of the ink landing position.

Procedure

1. Load the media.

2. Tap .

3. Tap [Media Settings]>[Printing Settings]>[Media Gap Adjustment].

4. Select [Simple Correction (Auto)] and tap [Next].

5. Tap [Execute].

The test pattern is printed and the media gap is adjusted automatically.

6. Tap [OK] when the completion screen appears.

7. Perform the operations shown below according to the [Result].

- If [Successful] is displayed on the operation panel, tap  to go back to the original screen.
- If [Failed] is displayed on the operation panel, manually adjust the media gap.



RELATED LINKS

- [P. 151 Manual Adjustment: Adjusting the Misalignment of the Ink Landing Position \(Media Gap Adjustment\)](#)

2. Correct the misalignment of printing and cutting with crop marks at the same time.

Use the following procedure to print the crop marks and cut the media, checking for misalignment in the positions. In this section, the crop marks are printed simply, and then the crop marks are read and a cutting test is performed without removing the media. To simulate the actual process—printing crop marks, removing the media, and then performing post-processing such as laminating—before loading the media and checking for cutting position misalignment, turn on **[Separate Test for Printing/Cutting with Crop Marks]**. For more information, refer to [Correcting the Misalignment of Printing and Cutting with Crop Marks \(Separate Test for Printing/Cutting with Crop Marks\)](#)(P. 189).

Procedure

1. Tap .
2. Tap **[Media Settings]>[Cutting Settings]>[Crop Cut Position Adjustment]**.
3. Tap  next to **[Separate Test for Printing/Cutting with Crop Marks]** to turn it off.
4. Tap **[Execute]** next to **[Printing Test 1 (Misalignment Check)]**.
Printing Test 1 is printed and cut. One test pattern is printed on the media.

5. Check Printing Test 1.

Check whether the printing position (shaded part) and the cutting position (red line) are aligned. An example of the printing position and the cutting position being misaligned is shown in the following figure.

[F] indicates the feed direction of the media (the feed direction) and [S] indicates the direction of print head movement (the scan direction).

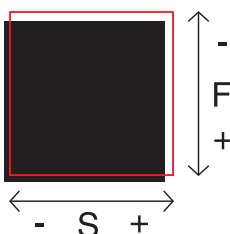

If the printing position and the cutting position are aligned, no corrections are necessary.

If the printing position and the cutting position are not aligned, proceed to the next procedure.

6. Tap **[Execute]** next to **[Printing Test 2 (Correction Values)]**.
Printing Test 2 is printed and cut.



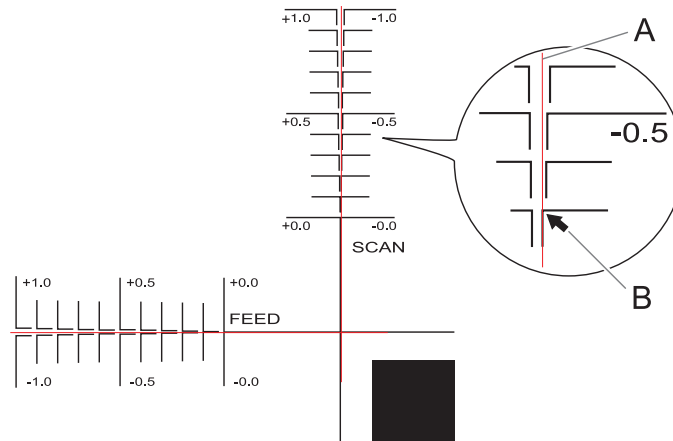

7. Check the correction values from the Printing Test 2 condition.

The point where the cutting line (A) intersects the correction-value scale (B) is the correction value. In the following figure, the correction value is "-0.3."



Check the media feed direction (the feed direction) and the direction of print head movement (the scan direction).



8. Set the correction values in the feed direction of the media (the feed direction) and the direction of print head movement (the scan direction).

- (1) Tap  or  next to [Correction Value (Feed)] to set the correction value in the feed direction of the media (the feed direction).
- (2) Tap  or  next to [Correction Value (Scan)] to set the correction value in the direction of print head movement (the scan direction).

9. Tap [Save].
The correction values are saved.

10. Tap [Execute] next to [Printing Test 1 (Misalignment Check)].
Printing Test 1 is printed and cut. If the printing and cutting lines are aligned, adjustment is complete. If further adjustment is needed, tap  or  next to [Correction Value (Feed)] and [Correction Value (Scan)] to fine-tune the printing and cutting position, and then [Save] the values.

MEMO

- Default settings
 [Correction Value (Feed)] (correction value of the media feed direction): 0.00 mm
 [Correction Value (Scan)] (correction value of the print head movement direction): 0.00 mm
- Depending on the changes in the condition of media caused by laminating and the loading position of the media before cutting, the positioning of cutting may be misaligned. In such cases, correct the misalignment of printing and cutting with crop marks.

11. Tap  to go back to the original screen.

RELATED LINKS

- [P. 189 Correcting the Misalignment of Printing and Cutting with Crop Marks \(Separate Test for Printing/Cutting with Crop Marks\)](#)

Correcting the Misalignment of Printing and Cutting with Crop Marks (Separate Test for Printing/Cutting with Crop Marks)

Due to changes in the thickness of media caused by laminating and misalignment of the loading position of the media before and after cutting, the positioning of printing and cutting may be misaligned even when you are using crop marks. Make corrections for misaligned printing and cutting for the media you are using and its condition.

In this test, so as to create the same conditions as the actual operation, print only the crop marks, remove the media, load the media again, and then cut the media.

1. Adjust the misalignment of the ink landing position.

Procedure

1. Load the media.

2. Tap .

3. Tap [Media Settings]>[Printing Settings]>[Media Gap Adjustment].

4. Select [Simple Correction (Auto)] and tap [Next].

5. Tap [Execute].

The test pattern is printed and the media gap is adjusted automatically.

6. Tap [OK] when the completion screen appears.

7. Perform the operations shown below according to the [Result].





- If [Successful] is displayed on the operation panel, tap  to go back to the original screen.
- If [Failed] is displayed on the operation panel, manually adjust the media gap.

RELATED LINKS

- [P. 151 Manual Adjustment: Adjusting the Misalignment of the Ink Landing Position \(Media Gap Adjustment\)](#)

2. Print only the crop marks.

Procedure

1. Tap .
2. Tap [Media Settings]>[Cutting Settings]>[Crop Cut Position Adjustment].
3. If  next to [Separate Test for Printing/Cutting with Crop Marks] is off, tap it to turn it on.
4. Tap [Execute] next to [Printing Test].
Printing of the test pattern starts.
The crop marks are printed. When printing is finished, you will return to the original screen.
5. Remove any media.
Use the following procedure to separate the media.
 - (1) Close the front cover.
 - (2) Tap [Change] next to [Output Start Location].
 - (3) Tap  to feed the media until there is a margin of 130 mm (5.12 in.) or more after the printed crop marks.
 - (4) Tap  to go back to the previous screen.
 - (5) Tap [Execute] next to [Sheet Cutting].
 - (6) Tap [Yes] on the confirmation screen.
6. Complete operations before cutting output for normal cutting with crop marks, such as laminating.

3. Perform a cutting test.

Procedure

1. Set up the media for which operations before cutting output, such as lamination, is complete.





2. Tap .

3. Tap [Media Settings]>[Cutting Settings]>[Crop Cut Position Adjustment].

4. If [Separate Test for Printing/Cutting with Crop Marks] is off, tap  to turn it on.

5. Tap [Execute] next to [Cutting Test].

The [Move the blade over a crop mark.] screen appears.

6. Tap , , , or  to move the center of the blade over the crop marks to use in the cutting test.

The center of the blade should only be over the crop marks, and does not need to be aligned with the center of the crop marks.

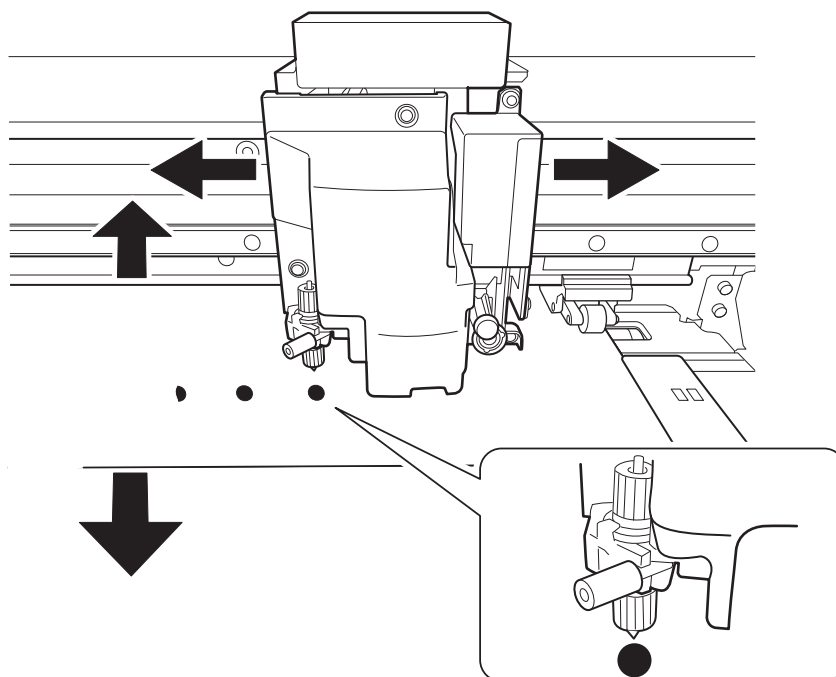

7. Tap [Execute].

The cutting test starts.

4. Set the correction values.

Procedure

1. View the results of the cutting test to determine the correction values.

Check whether the crop mark (shaded part) and the cutting position (red line) are aligned. An example of the crop mark and the cutting position being misaligned is shown in the following figure.

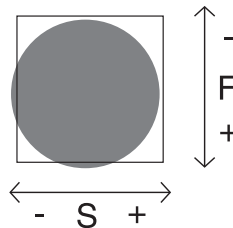



- If the test printed crop marks are inside the cutting line, correction is not necessary.
- If the test printed crop marks are extending beyond the cutting line, correction is necessary.



[F] indicates the feed direction of the media (the feed direction) and [S] indicates the direction of print head movement (the scan direction). ("F," "S," "+," "-", " and the arrows are not displayed on the actual test pattern.)

MEMO

Determine the values so as to correct the misalignment of the cutting position. In the case of the above figure, feed direction [F] is misaligned in a negative direction and scan direction [S] in a positive direction. Therefore, set the correction values for the feed direction [F] to positive values and the scan direction [S] to negative values. Measure the actual misalignment amount when determining the value.

2. Set the correction values in the feed direction of the media (the feed direction) and the direction of print head movement (the scan direction).

(1) Tap  or  next to [Correction Value (Feed)] to set the correction value in the feed direction of the media (the feed direction).

(2) Tap  or  next to [Correction Value (Scan)] to set the correction value in the direction of print head movement (the scan direction).

3. Tap [Save].

4. Perform steps 5 to 7 of 3. **Perform a cutting test.(P. 191)** again to check whether the correction was successful.

- If the test printed crop marks are inside the cutting line, correction is complete.
- If the test printed crop marks are extending beyond the cutting line, redo the correction.

5. Tap  to go back to the original screen.

MEMO

- Default settings
 [Correction Value (Feed)] (correction value of the media feed direction): 0.00 mm
 [Correction Value (Scan)] (correction value of the print head movement direction): 0.00 mm

- You can also make corrections of printing and cutting positions at the same time without removing the media.

RELATED LINKS

- [P. 186 Correcting the Misalignment of Printing and Cutting with Crop Marks \(Concurrent Test for Printing and Cutting with Crop Marks\)](#)

Correcting the Reading Sensor

Depending on the characteristics of the media, such as reflectivity and colors, the machine may not be able to read the crop marks. In such cases, correct the sensor for reading crop marks.

Procedure

1. Load the media.
2. Tap .
3. Tap [Media Settings]>[Other Media Settings]>[Multi Sensor Adjustment].
4. Tap [Execute].
5. Perform the operations shown below according to the [Adjustment Result].
 - If [Successful] is displayed on the operation panel, proceed to the next procedure.
 - If [Failed] is displayed on the operation panel, the following causes are possible, so take countermeasures and redo the correction.

Cause	Countermeasures
The lighting in the room where the printer is installed or vicinity of the printer is too bright.	Adjust the lighting in the room.
Correction failed for some reason.	Redo the correction.
Crop marks cannot be recognized on the media being used.	Change the media type.
There is ink on the multi sensor because, for example, the media strikes it immediately after printing.	Contact your authorized Roland DG Corporation dealer.

6. Tap  to go back to the original screen.

Optimizing Work Efficiency

Managing the Media Settings.....	195
Changing the Media Settings	195
Checking the Registered Media Settings	197
Changing the Media Name	199
Duplicating Media Settings.....	200
Deleting Media Settings	201
Adjusting the Output-start Location.....	202
Setting the Base Point	202
Reducing Output Time	204
Speeding Up Output for Narrow Media.....	204
Other Useful Functions	205
Using the Print Light (Interior Light)	205
Performing Printing Tests Arranged Horizontally	206

Managing the Media Settings

Changing the Media Settings

Use the following procedure to change the media settings. These settings can only be changed for the media being set up.

Procedure

1. Load the media.
2. Tap .
3. Tap [Media Settings]>[List of Media Settings].
4. Tap the setting to change to move to the screen for editing this setting.

The media settings that can be changed are as follows.

Menu item	Reference page
[Print Head Height]	P. 153 Changing the Print Head Height
[Feed Correction]	P. 149 Manual Adjustment: Reducing Horizontal Bands (Feed Correction Function)
[Media Gap Adjustment]	P. 151 Manual Adjustment: Adjusting the Misalignment of the Ink Landing Position (Media Gap Adjustment)
[Blade Adjustment]	P. 173 Fine-tuning the Cutting Conditions
[Print & Cut Position Adjustment]	P. 181 Correcting the Misalignment of Printing and Cutting
[Crop Cut Position Adjustment]	P. 186 Correcting the Misalignment of Printing and Cutting with Crop Marks (Concurrent Test for Printing and Cutting with Crop Marks) P. 189 Correcting the Misalignment of Printing and Cutting with Crop Marks (Separate Test for Printing/Cutting with Crop Marks)
[Cutting Distance Correction]	P. 177 Performing Distance Correction during Cutting
[Over Cut]	P. 178 Cutting to Make It Possible to Cut Corners Attractively (Over Cut)
[Heater Temperature]	P. 164 Changing the Print Heater Temperature P. 166 Changing the Dryer Temperature
[Dry After Printing]	P. 170 Drying the Trailing Edge of the Printing Area on the Dryer
[Multi Sensor Adjustment]	P. 193 Correcting the Reading Sensor
[Drying Time Per Scan]	P. 155 Using Hard-to-Dry Media
[Media Suction Force]	P. 156 Using Media That Wrinkles Easily/ Does Not Move Smoothly

Managing the Media Settings

Menu item	Reference page
[Printing Movement Range]	P. 204 Speeding Up Output for Narrow Media
[Media Sticking Prevention]	P. 157 Using Sticky Media
[Middle Pinch Auto Raise/Lower]	P. 161 Use Middle Pinch Rollers When Pulling Back or Feeding Media

5. If you have changed a setting, tap [Save].

6. Tap  to go back to the original screen.

Checking the Registered Media Settings

Procedure

1. Tap .
2. Tap [Media Management].
The registered media settings are displayed in a list.
3. Tap a media setting.
4. Tap [List of Media Settings].
The registered media setting values are displayed in a list.



Menu item	Reference page
[Print Head Height]	P. 153 Changing the Print Head Height
[Feed Correction]	P. 149 Manual Adjustment: Reducing Horizontal Bands (Feed Correction Function)
[Media Gap Adjustment]	P. 151 Manual Adjustment: Adjusting the Misalignment of the Ink Landing Position (Media Gap Adjustment)
[Blade Adjustment]	P. 173 Fine-tuning the Cutting Conditions
[Print & Cut Position Adjustment]	P. 181 Correcting the Misalignment of Printing and Cutting
[Crop Cut Position Adjustment]	P. 186 Correcting the Misalignment of Printing and Cutting with Crop Marks (Concurrent Test for Printing and Cutting with Crop Marks) P. 189 Correcting the Misalignment of Printing and Cutting with Crop Marks (Separate Test for Printing/Cutting with Crop Marks)
[Cutting Distance Correction]	P. 177 Performing Distance Correction during Cutting
[Over Cut]	P. 178 Cutting to Make It Possible to Cut Corners Attractively (Over Cut)
[Heater Temperature]	P. 164 Changing the Print Heater Temperature P. 166 Changing the Dryer Temperature
[Dry After Printing]	P. 170 Drying the Trailing Edge of the Printing Area on the Dryer
[Multi Sensor Adjustment]	P. 193 Correcting the Reading Sensor
[Drying Time Per Scan]	P. 155 Using Hard-to-Dry Media
[Media Suction Force]	P. 156 Using Media That Wrinkles Easily/ Does Not Move Smoothly
[Printing Movement Range]	P. 204 Speeding Up Output for Narrow Media

Menu item	Reference page
[Media Sticking Prevention]	P. 157 Using Sticky Media
[Middle Pinch Auto Raise/Lower]	P. 161 Use Middle Pinch Rollers When Pulling Back or Feeding Media

- 5. Tap  to go back to the original screen.

Changing the Media Name



Procedure

1. Tap .
2. Tap [Media Management].
The registered media settings are displayed in a list.
3. Tap the media whose name you want to change.
4. Tap .
5. Tap the input field and enter the media name.
You can use up to 15 alphanumeric characters.
6. Tap [OK] to confirm your entry.
7. Tap  to go back to the original screen.

Duplicating Media Settings

Use the following procedure to duplicate existing media settings.

Procedure

1. Tap .
2. Tap [Media Management].
The registered media settings are displayed in a list.
3. Tap the media setting to duplicate.
4. Tap [Duplicate Media].
A screen for entering the name of the duplicated media appears. To create this name, [COPY] is added at the start of the name of the media being duplicated.
5. Enter the media name and tap [OK].
6. Tap  to go back to the original screen.



Deleting Media Settings

Use the following procedure to delete existing media settings.

MEMO

This operation cannot be performed on the media being set up. To perform this operation, first cancel media setup.

Procedure

1. Tap .
2. Tap [Media Management].
The registered media settings are displayed in a list.
3. Tap the media to be deleted.
4. Tap [Delete Media].
5. Tap [Yes] when the confirmation screen appears.
The media settings are deleted, and you are returned to the screen listing the registered media settings.
6. Tap  to go back to the original screen.

Adjusting the Output-start Location

Setting the Base Point

Set the base point in order to determine the area on the loaded media in which to print (the output area).

The base point (④) indicates the right edge of the output area (①). (②: Media feed direction, ③: print-head carriage movement direction) You can print without setting the base point, but setting the output area enables you to use media without being wasteful and also to print on the targeted location.

Set the base point for each individual page. When the printing of one page finishes, the base point returns to its default value.

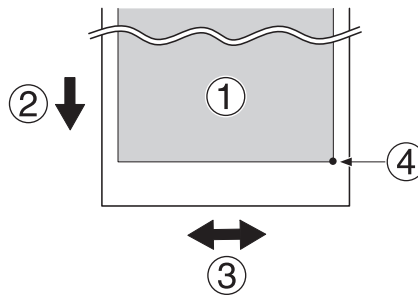

MEMO





- Note that the left and right positions are not restored to their defaults for test patterns.

Procedure

1. Tap .

2. Tap  [Move].

The movement screen appears.

3. Tap , ,  or  to move the center of the blade to the position that you want to set as the base point.

Tap  or  to move the media. Tap  or  to move the cutting carriage.

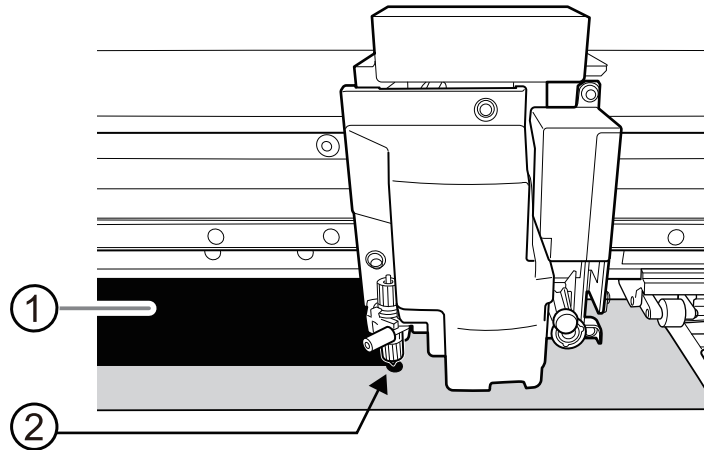

- ①: Output area
- ②: Base point (right edge of the output area)

4. Once the position has been decided, tap [Set Base Point Here] to confirm it.
The base point position is updated, and you are returned to the home screen.

MEMO

The display of the icon on the home screen changes to indicate that the base point position has been updated.

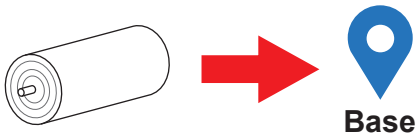

Reducing Output Time

Speeding Up Output for Narrow Media

This shortens output time by reducing the width of head movement to the minimum necessary. This is effective when the width of the media or the output data is narrow.

Procedure

1. Load the media.
2. Tap .
3. Tap [Media Settings]>[Other Media Settings]>[Printing Movement Range].
4. Specify the range of print head movement during printing.

[Output Data Width]	Matches the range of print head movement to the output data. Movement is limited to the minimum amount necessary, and this can be expected to yield the fastest output. Note, however, that because the speed of media movement is no longer constant, colors may be uneven.
[Media Width]	Matches the range of print head movement to the width of the media.
[Full Width]	The print heads move from one end of the machine to the other. Makes the speed of media movement constant at all times and produces the most stable printing result.

5. Tap [Save] to confirm your entry.
6. Tap  to go back to the original screen.

MEMO

- Default setting: [Full Width]

Other Useful Functions

Using the Print Light (Interior Light)

You can select the status of the light that shines on the platen.

Procedure

1. Tap .

2. Tap [Preferences]>[Print Light].

3. Select the status of the print light.

[Auto]	The light is turned on/off automatically according to the status of the printer.
[On]	The light is on at all times.
[Off]	The light is off at all times.

4. Tap [Save] to confirm your entry.

5. Tap  to go back to the original screen.



MEMO

- Default setting: [Auto]

Performing Printing Tests Arranged Horizontally

When performing printing tests successively, you can select [Feed] (vertical printing) or [Scan] (horizontal printing) as the print position for the second and later tests in comparison to the first test.

Procedure

1. Tap .
2. Tap [Preferences]>[Printing Test Position].
3. Select [Scan].
4. Tap [Save] to confirm your entry.
5. Tap  to go back to the original screen.

MEMO

Default setting: [Feed]

Optimizing Operation Management





Managing the Operations Appropriately and Efficiently	208
Setting the Current Date/Time and Using It for Maintenance.....	208
Checking the Remaining Media.....	209
Showing/Hiding Notifications	211
Setting the Activation Interval for Sleep Mode (Power-saving Feature)	212
Managing the Basic Settings of the Printer	213
Changing the Display Language	213
Changing the Units of Measurement	214
Viewing Printer Information	215
Viewing Network Information	216
Adjusting the Brightness of the Operation Panel.....	217
Turning Off Operation Panel Sounds.....	218
Returning All Settings to Factory Defaults	219

Managing the Operations Appropriately and Efficiently

Setting the Current Date/Time and Using It for Maintenance

Use the following procedure to set the current date and time. By setting this, when you perform a printing test the printing test date and time will be printed alongside the printed test pattern. Notifications prompting you to perform manual cleaning and mix the ink will also be displayed at appropriate times.

Procedure

1. Tap .
2. Tap [System Information]>[Date/Time].
3. Tap  or  to set the date and time.
4. Tap [Save] to confirm your entry.
5. Tap  to go back to the original screen.

Checking the Remaining Media

You can display how much of the media in use is left. By setting the amount of media currently remaining at the start, the amount remaining will be constantly displayed on the screen until it reaches zero.

Because the amount of media remaining is not updated automatically when you change the media, redo the setting whenever you change the media.

MEMO



The remaining amount that is displayed is only an estimate. Accuracy is not assured.

Procedure

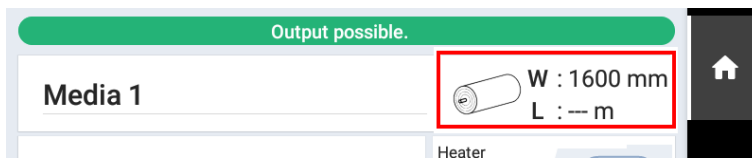
1. Load the media.
2. Tap the following location on the home screen.



The [Remaining Media Management] screen appears.

3. Tap  or  to enter the length of the remaining media.
4. Tap [Save] to confirm your entry.
5. Tap  to go back to the original screen.

The remaining media is displayed.

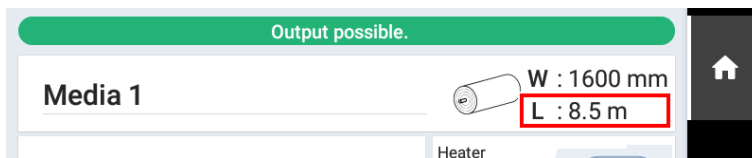

Printing the Amount of Remaining Media

Print the amount of remaining media, which is displayed on the home screen.

Use this when you want to make a record of the remaining length of the media currently in use. Printing the amount of media remaining before you change the media enables you to refer to the printed record and use the value to make the setting for the remaining amount the next time you use the media.

Note, however, that if you continue printing, the next printing operation will start on top of the portion where the amount of remaining media is printed. If you want to continue printing, separate the media before starting the next printing operation.

Procedure

1. Check that the amount of remaining media is displayed on the home screen.
If it is not, set the amount of remaining media by referring to [Checking the Remaining Media\(P. 209\)](#).

2. Tap the following location on the home screen.

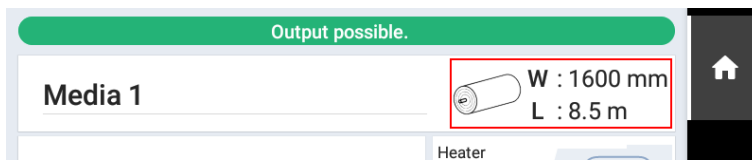

The [Remaining Media Management] screen appears.

3. Tap [Printing Remaining Media Amount]>[Execute].
The amount of remaining media is printed.

Showing/Hiding Notifications

Use the following procedure to show/hide the following notifications, which prompt operators to perform proper operations.

Procedure

1. Tap .

2. Tap [Preferences]>[Notifications On/Off].

3. Tap  to show/hide the notifications.

	Displayed notification	Description
[Ink Mixing Notification]	[The time for ink mixing has arrived.]	Prompts you to mix the ink in the ink pouch tray to prevent ink precipitation. When enabled, a message recommending mixing the ink is displayed once a week.
[Middle Pinch Roller Placement Notification]	[Place the middle pinch rollers over all the grit rollers.]	Prompts you to use the middle pinch rollers, improving media feeding accuracy and preventing the media from coming loose. When enabled, this message appears when the middle pinch rollers have not been placed.
[Media Clamp Placement Notification]	[Install the media clamps correctly.]	Prompts you to correctly place the media clamps to prevent the media from coming loose. When enabled, this message appears when the media clamps are not placed at the edges of the media.
	[Media clamps could not be detected.]	This message appears when the media clamps cannot be detected because they are hidden by the media or are dirty with, for example, ink.

4. Tap [Save] to confirm your entry.

5. Tap  to go back to the original screen.

MEMO





Default setting:

- [Ink Mixing Notification]: Off
- [Middle Pinch Roller Placement Notification]: On
- [Media Clamp Placement Notification]: On

Setting the Activation Interval for Sleep Mode (Power-saving Feature)

This setting is used to set how long it should take until the machine goes into sleep mode (the state in which the power-saving feature is working) when no output data is received and no operations are performed for a continued length of time.

Procedure

1. Tap .
2. Tap [Preferences]>[Sleep Time].
3. Tap  or  to set the time.
4. Tap [Save] to confirm your entry.
5. Tap  to go back to the original screen.

MEMO

- Default setting: [30 min.]

Managing the Basic Settings of the Printer

Changing the Display Language

This feature sets the language displayed on the display screen of the operation panel.

Procedure

1. Tap .
2. Tap [System Information]>[Language].
3. Tap [Language].
4. Select the display language.
5. Tap [OK].
6. Tap [Save] to confirm your entry.
The display language is changed, and you are returned to the home screen.

MEMO



Default settings

- [Language]: ENGLISH

Changing the Units of Measurement

Use the following procedure to set the units of measurement displayed on the display screen of the operation panel.

Procedure

1. Tap .
2. Tap [System Information]>[Units].
3. Tap [Length].
4. Select the unit.
5. Tap [Save] to confirm your entry.
6. Tap [Temperature].
7. Select the unit.
8. Tap [Save] to confirm your entry.
9. Tap  to go back to the original screen.



MEMO

- Default settings
 - [Length]: mm
 - [Temperature]: °C

Viewing Printer Information

This is a method for viewing information of this machine, such as serial number and ink type.



Procedure

1. Tap .
2. Tap [System Information]>[Machine Information].
You can check the following information:
 - [Model]: Model name
 - [Serial Number]: Serial number
 - [Ink Type]: Ink type
 - [Firmware Version]
 - [MAC Address]
3. Tap  to go back to the original screen.

Viewing Network Information

Use the following procedure to view network information such as the IP address and default gateway.

Procedure

1. Tap .
2. Tap [System Information]>[Network].
You can check the following information:
 - [Obtain IP Address Automatically]: Enables/disables the automatic obtaining of IP addresses via DHCP. When this is disabled, tap  to change the following settings.
 - [IP Address]
 - [Subnet Mask]
 - [Default Gateway]
3. Tap  to go back to the original screen.

MEMO





- For information on how to set up a network, see the "Setup Guide."

RELATED LINKS

- [SG3-540/300 Setup Guide](#)

Adjusting the Brightness of the Operation Panel

Procedure

1. Tap .
2. Tap [System Information]>[Screen Brightness].
3. Tap  or  to adjust the brightness.
The larger the value, the brighter the screen.
4. Tap [Save] to confirm your entry.
5. Tap  to go back to the original screen.



MEMO

- Default setting: [50%RH]

Turning Off Operation Panel Sounds

Use the following procedure to turn off the sound when you tap the operation panel.

Procedure

1. Tap .
2. Tap [System Information]>[Screen Operation Sound].
3. Tap [Off].
The operation sound turns off.
4. Tap [Save] to confirm your entry.
5. Tap  to go back to the original screen.

MEMO



- Default setting: [On]

Returning All Settings to Factory Defaults

This menu returns all settings to the same as their factory defaults.

The settings for [Language] and [Units] are not returned to their factory default values.

Procedure

1. Tap .
2. Tap [Preferences]>[Reset to Factory Defaults].
3. Tap [Reset].
4. Tap [Yes] on the confirmation screen.
5. Tap  to go back to the original screen.

Maintenance

Introduction

Important Notes on Handling and Use	222
Printer	222
Ink Pouches.....	222
Basic Maintenance Knowledge.....	223
Types and Timing of Maintenance	223
Measures When the Printer Is Not in Use for a Prolonged Period	225

Important Notes on Handling and Use

Printer

- This machine is a precision device.
 - Never subject the machine to impacts or excessive force.
 - Never needlessly put your hand or fingers inside the cover, the ink-pouch ports, or other internal areas of the machine.
- Install the machine in a suitable location.
 - Install the machine in a location having the specified temperature and relative humidity.
 - Install the machine in a quiet, stable location offering good operating conditions.
- The print heads are delicate.
 - Never needlessly touch or allow media to scrape them.
 - The print heads may be damaged if allowed to dry out. The machine prevents desiccation automatically, but improper operation may render this feature inoperative. Operate properly, as specified in this manual.
 - Never leave the machine with an ink pouch removed. Remaining ink in the printer may harden and clog the print heads.
 - Depending on the situation, the print heads require various types of cleaning. Read this manual thoroughly and perform the appropriate maintenance at the appropriate times.
 - The print heads are components that wear out. Periodic replacement is required, with the frequency of replacement depending on use.
- This machine becomes hot.
 - Never cover the ventilation holes with cloth, tape, or anything else.

Ink Pouches

- Ink pouches come in various types.
 - Use a type that is compatible with the printer.
- Never subject the ink pouches to impacts or attempt to disassemble them.
 - Never drop the ink pouches or shake them forcefully. The impact may rupture the internal pouches and cause the ink to leak.
 - Never attempt to disassemble.
 - Never attempt to refill the ink.
 - If ink gets on your hands or clothing, wash it off as soon as possible. Removal may become difficult if allowed to stand.
- Storage
 - Store the ink pouches unopened in a well-ventilated location at a temperature of -5 to 40°C (23 to 104°F). However, do not store the ink cartridges for a prolonged period of time in low or high temperature environments.

Basic Maintenance Knowledge

Types and Timing of Maintenance

To use this machine under its optimal conditions, it is important to perform the appropriate maintenance at the appropriate times.

Regular Maintenance

These are the maintenance items that are required on a daily basis.

Timing	Category	Item
Before daily operations	Print head check	P. 117 Step 1: Performing a Nozzle Drop-out Test
After daily operations	Cleaning the machine	P. 228 Cleaning the Media Path
		P. 229 Cleaning the Knife Carriage Roller
If a message appears	Cleaning around the print heads	P. 230 Cleaning around the Print Heads
If the Discharged Fluid Disposal Message Appears	Disposing of discharged fluid	P. 240 If the Discharged Fluid Disposal Message Appears

Advanced Maintenance

Maintenance that is performed in an emergency. Some of this maintenance consumes a large amount of ink, so thoroughly read the explanation, and then perform the operation at the appropriate point in time.

Timing	Category	Item
If colors are uneven	Ink mixing	P. 246 Mixing the Ink by Shaking the Pouch Tray
When dot drop-out or dot displacement occurs	Checking and cleaning the print heads	P. 117 Step 1: Performing a Nozzle Drop-out Test
		P. 118 Step 2: Normal Cleaning Method
		P. 244 Medium Cleaning Method
		P. 245 Powerful Cleaning Method
		P. 231 Manual Cleaning Method
When uneven color, dot drop-out, and dot displacement issues are not resolved even by performing the above operations	Replacing the ink in all the ink paths*1	P. 247 Ink Renewal Method
When the operation panel is dirty	Cleaning the operation panel	P. 254 Operation Panel Cleaning Method

*1 This cleaning consumes a large amount of ink.

Replacing Consumable Parts

These items are for replacement of consumable parts. Thoroughly read the explanation, and then perform the operation at the appropriate point in time.

Basic Maintenance Knowledge

Timing	Category	Item
When a message appears	Replacing consumable parts <ul style="list-style-type: none"> • Wiper • Tray pad 	P. 256 Replacing the Wiper and the Tray Pad
	Cleaning the machine	P. 259 Cleaning the Wiper Tray
When a cutting edge becomes dull	Replacing consumable parts <ul style="list-style-type: none"> • Blade • Separating knife 	P. 262 Replacing the Blade
		P. 269 Replacing the Separating Knife

Measures When the Printer Is Not in Use for a Prolonged Period

Be sure to follow the instructions shown below when the printer is not in use for a prolonged period.

- Empty the drain bottle.

If you know that you will not use the machine for a prolonged period, empty the drain bottle. When the main power is on, the machine periodically performs automatic maintenance in which fluid is discharged.

The drain bottle is filled when the following periods elapse, so periodically discard the discharged fluid.

- Approximately 2 weeks after the message [**When output, cleaning, and other operations are completed, discard the discharged fluid.**] is displayed or approximately 150 days after the drain bottle is emptied

[P. 240 If the Discharged Fluid Disposal Message Appears](#)

- Do not allow the machine to run out of ink or cleaning liquid.

The machine discharges ink and cleaning liquid during the automatic maintenance that is performed periodically. Set in the machine ink and cleaning liquid pouches having sufficient remaining ink and cleaning liquid. The machine cannot perform automatic maintenance if it has run out of ink or cleaning liquid.

- Switch on the sub power once a month.

Switch on the sub power once a month. When you turn on the power, the machine automatically performs operations such as those to keep the print heads from drying out. Leaving the machine unused for a prolonged period may damage the print heads, so be sure to switch on the power to perform these automatic operations.

- Keep the machine at a constant temperature and relative humidity.

Even when the machine is not in use, keep it at a temperature of 5 to 40°C (41 to 104°F) and a relative humidity of 20 to 80% (with no condensation). Temperatures that are too high may degrade the ink and cause malfunctions. Temperatures that are too low may cause the ink to freeze and damage the print heads.

RELATED LINKS

- [P. 109 Ink Pouch Replacement](#)
- [P. 113 Cleaning Liquid Pouch Replacement](#)

Regular Maintenance

Print Head Check before Printing	227
Performing a Nozzle Drop-out Test	227
Cleaning the Machine	228
Cleaning the Media Path	228
Cleaning the Knife Carriage Roller	229
Cleaning around the Print Heads	230
Manual Cleaning Method	231
Consumable Products and Parts Related to Manual Cleaning.....	237

Print Head Check before Printing

Performing a Nozzle Drop-out Test

Before you carry out actual printing, perform a printing test to ensure no dot drop-out or dot displacement occurs. If dot drop-out or dot displacement occurs, perform cleaning of the print heads (normal cleaning).

MEMO

When performing printing tests successively, you can select **[Feed]** (vertical printing) or **[Scan]** (horizontal printing) as the printing position for the second and later tests in comparison to the first test.

[P. 206 Performing Printing Tests Arranged Horizontally](#)

Procedure

1. Tap  **[Nozzle Drop-out Test]** on the home screen.
2. Tap **[Execute]** next to **[Printing Test]**.
Printing of the test pattern starts.
3. Check whether there is dot drop-out or dot displacement in the test pattern.
Missing blocks indicate dot drop-out. Collapsed or inclined blocks indicate dot displacement.

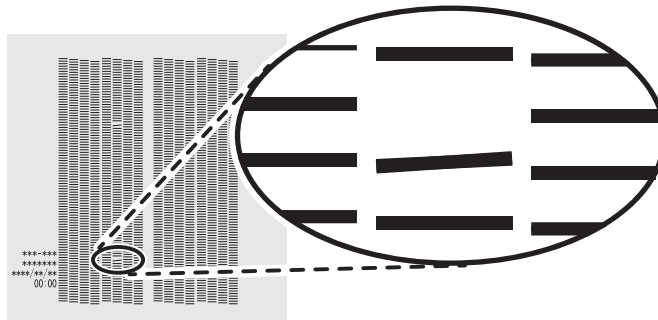

4. If you have opened the front cover, close it.
If no dot drop-out or dot displacement occurs, preparations for output are finished.

RELATED LINKS

- [P. 243 When Dot Drop-out or Dot Displacement Occurs](#)

Cleaning the Machine

Cleaning the Media Path

Wipe away any ink or grime on the media path and other areas as part of the daily cleaning procedure. It is easy for ink or grime to affix to the media path, and, if left unattended, this will contaminate new media and have a negative effect on the transport of media when it is output. Pinch rollers, grit rollers, and the platen are particularly prone to the buildup of grime.

⚠ WARNING

Never use a solvent such as gasoline, alcohol, or thinner to perform cleaning.
Doing so may cause a fire.

⚠ CAUTION

Before attempting cleaning, switch off the sub power and wait until the platen and dryer cool (approximately 30 minutes).

Sudden movement of the machine may cause injury, or hot components may cause burns.

IMPORTANT

- This machine is a precision device and is sensitive to dust and dirt. Perform cleaning on a daily basis.
- Never attempt to oil or lubricate the machine.

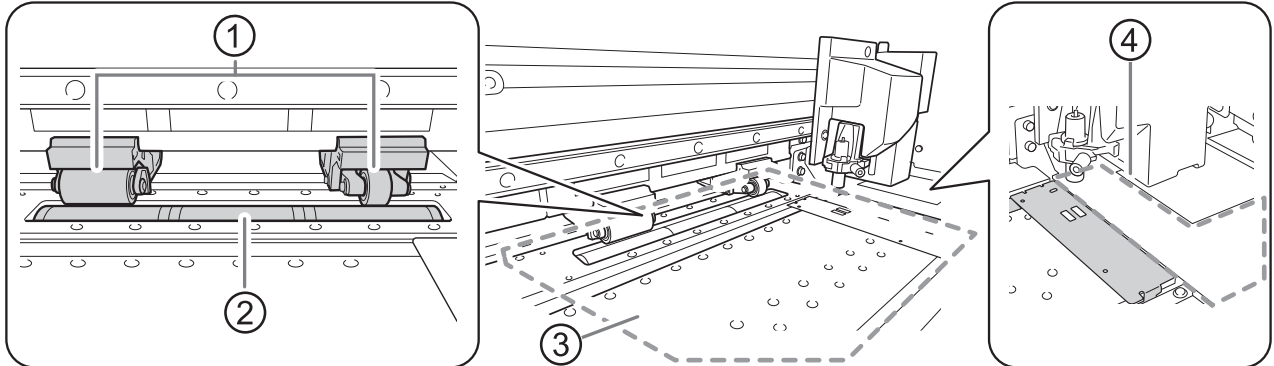

Clean by wiping with a cloth moistened by neutral detergent diluted with water then wrung dry.

①	Pinch roller	These are the positions where the media is fixed in place or transported, so it is easy for ink and grime to affix to these positions. Failure to clean this part properly may result in the transfer of grime to the surface of media.
②	Grit roller	These are the positions where the media is fixed in place or transported, so it is easy for grime to affix to these positions. Remove buildup of media scraps and other material using a brush. Never use a metal brush.
③	Platen	Wipe away any buildup of ink, grime, or cut media on the media path and in the grooves.
④	Near the wiper tray	Wipe away any cut media that sprays onto the area around the wiper tray during media cutting.

Cleaning the Knife Carriage Roller

Paper dust affixes to the separating knife carriage roller during media separation. Periodically wipe the area clean.

⚠ WARNING

Never use a solvent such as gasoline, alcohol, or thinner to perform cleaning.
Doing so may cause a fire.

⚠ CAUTION

Before attempting cleaning, switch off the sub power and wait until the platen and dryer cool (approximately 30 minutes).

Sudden movement of the machine may cause injury, or hot components may cause burns.

IMPORTANT

- This machine is a precision device and is sensitive to dust and dirt. Perform cleaning on a daily basis.
- Never attempt to oil or lubricate the machine.

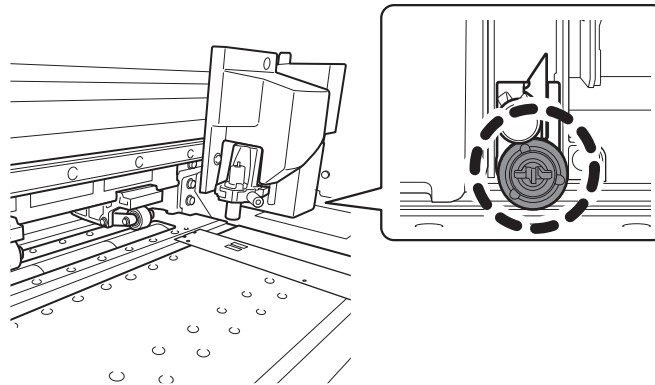

Clean by wiping with a cloth moistened by neutral detergent diluted with water then wrung dry.

Cleaning around the Print Heads

The print heads are important components that discharge ink. They require periodic and appropriate maintenance. Cleaning around the print heads is known as "manual cleaning." Be sure to perform manual cleaning in the following situations.

When a Message Appears

When a message appears, you can tap  on the home screen to check the notification details. Tap the notification to display the manual cleaning menu screen.

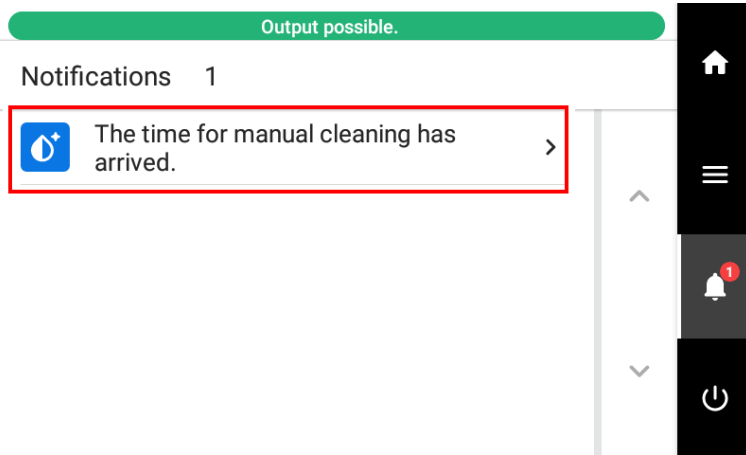

When Symptoms That Cannot Be Improved with Powerful Cleaning Occur

When any of the symptoms given below occur and powerful cleaning is not effective, perform manual cleaning.

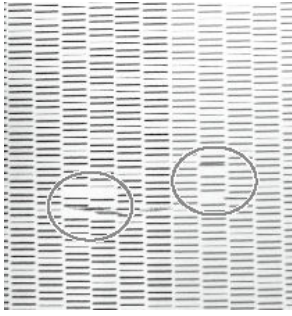
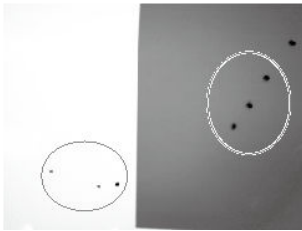
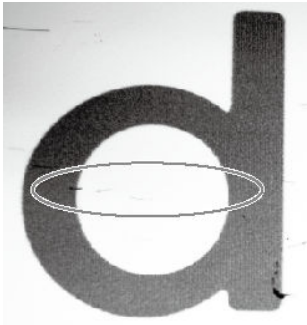
Dot drop-out/Dot displacement	Ink drips	Dragging dirt
		
Dust or other foreign matter adheres to the print heads and impedes correct ink discharge.	Ink pools in dust or dirt adhered to the print heads, and drips onto the media.	The phenomenon where dirt or dust accumulates on the print heads.

MEMO

Wiper replacement may also be effective in improving these symptoms.

RELATED LINKS

- [P. 256 Replacing the Wiper and the Tray Pad](#)

Manual Cleaning Method

If the notification [The time for manual cleaning has arrived.] is displayed or if dot drop-out or ink drip issues that cannot be improved with powerful cleaning occur, perform manual cleaning.

⚠ WARNING

Be sure to perform operations as specified by the instructions, and never touch any area not specified in the instructions.

Sudden movement of the machine may cause injury.



IMPORTANT

Important notes on this procedure

- Before attempting this operation, remove any media.
- To prevent the print heads from drying out, finish this procedure in 30 minutes or less. A warning beep sounds after 30 minutes.
- Never use any implements other than the included cleaning sticks. Cotton swabs or other lint-producing items may damage the print heads.
- Do not use cleaning liquid other than the included cleaning liquid.
- Use one cleaning stick per cleaning session, and then discard the stick after use. Reusing cleaning sticks will adversely affect the printing results.
- Do not put a cleaning stick that has been used for cleaning into the cleaning liquid. Doing so will deteriorate the cleaning liquid.
- Never rub the print head surface (nozzle surface).
- If you use up the cleaning sticks or cleaning liquid, contact your authorized Roland DG Corporation dealer or visit our website (<https://www.rolanddg.com/>).

If a warning beep sounds during cleaning

- A warning beep sounds 30 minutes after operation starts. Stop work, close all the covers, and then tap [Finish All] to end the manual cleaning mode. After that, restart the procedure from the beginning.

Required items	
	
Cleaning sticks	Cleaning liquid



1. Clean the print head caps.

Procedure

1. Remove any media.
2. Tap .
3. Tap [Cleaning]>[Manual Cleaning].
4. Tap [Execute].

MEMO

The procedure is displayed on the operation panel.

- Tap  or  to check the procedure.
- If you complete the work without viewing the instructions, tap [Finish All].

The print heads move to the left end of the machine.

5. Open the right cover.

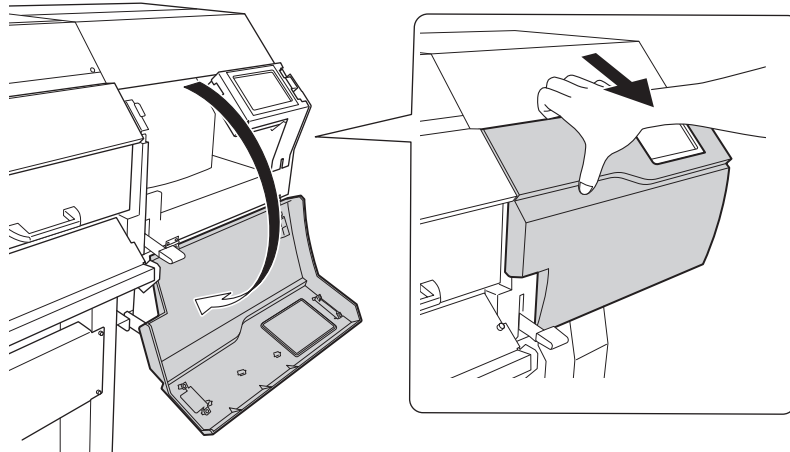

6. Touch the location shown in the figure to discharge any static electricity.

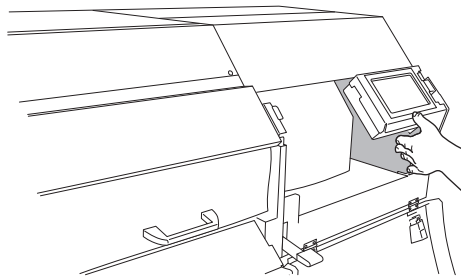

7. Moisten the cleaning stick with the cleaning liquid.

IMPORTANT

Be sure to use one of the included cleaning sticks.



8. Clean the locations shown in the following figure.
Be especially careful to clean away any fibrous dust (lint).

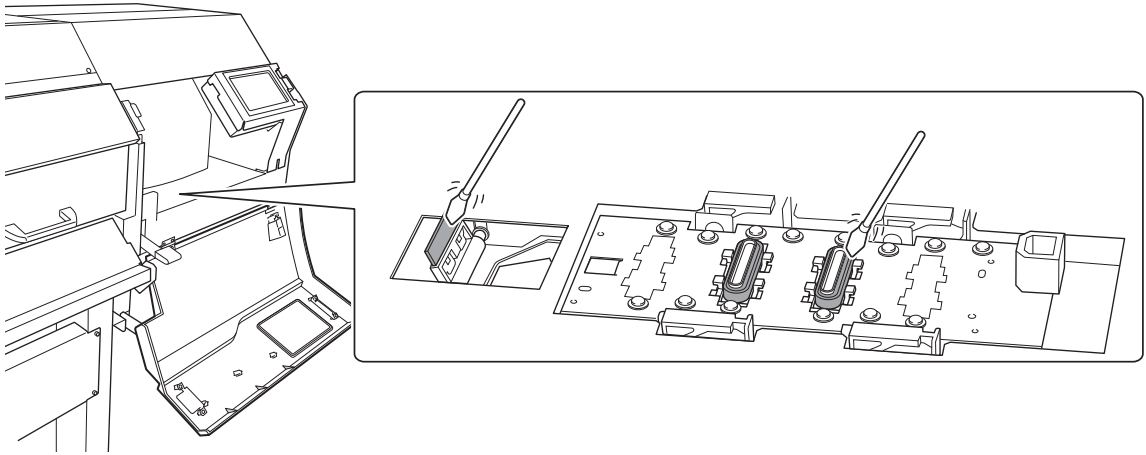

9. When you have finished cleaning, close the right cover.

2. Clean the print heads.

Procedure

1. Open the left cover.

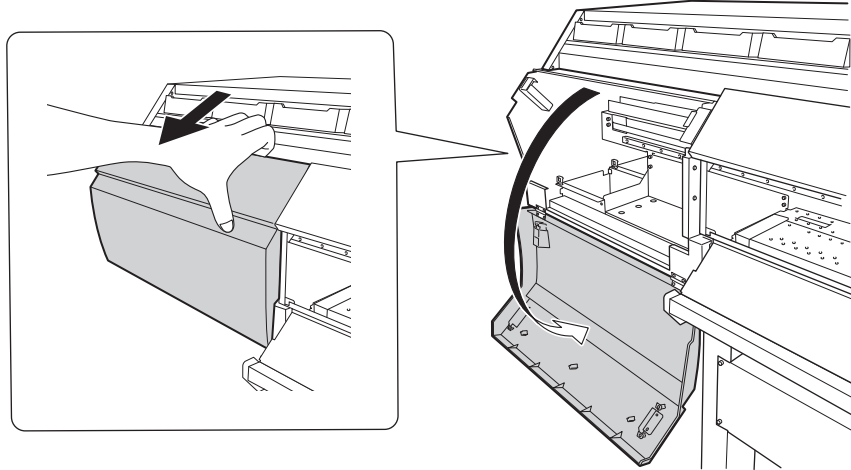

2. Moisten the cleaning stick with the cleaning liquid.

IMPORTANT

Be sure to use one of the included cleaning sticks.



3. Clean the locations shown in the following figure.
Be especially careful to clean away any fibrous dust (lint).

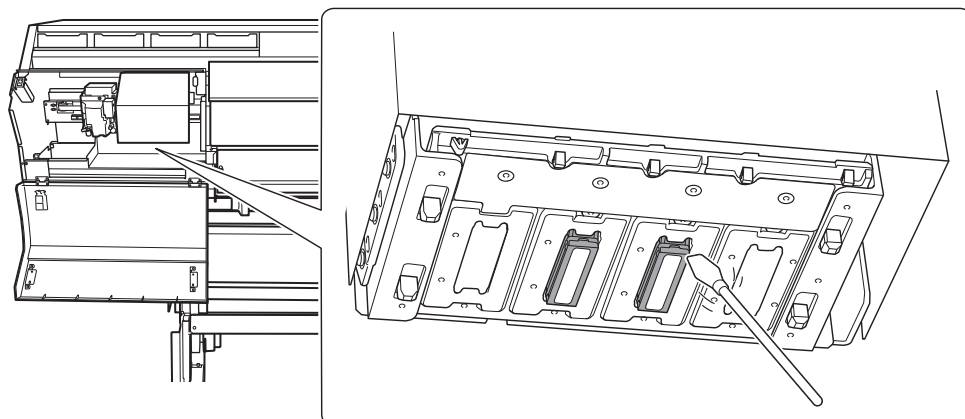

4. Close the left cover.

5. Tap [Finish All].

[Normal cleaning in progress.] is displayed at the top of the screen, and cleaning starts. The (approximate) remaining time for the procedure is displayed on the screen.

6. Tap  to go back to the original screen.

3. Perform a printing test to check the results.

Procedure

1. Load the media.
[P. 30 Setup of New Media](#)
2. Tap  [Nozzle Drop-out Test] on the home screen.
3. Tap [Execute] next to [Printing Test].
Printing of the test pattern starts.
4. Check whether there is dot drop-out or dot displacement in the test pattern.
Missing blocks indicate dot drop-out. Collapsed or inclined blocks indicate dot displacement.

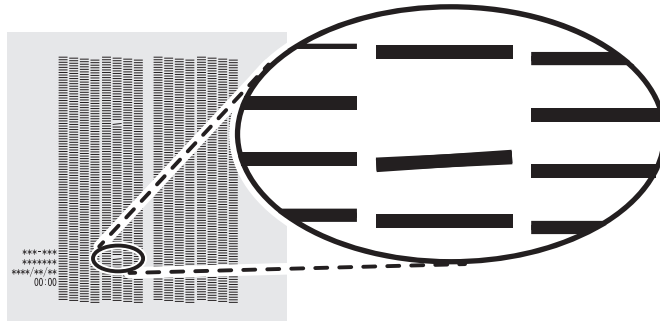

5. If you have opened the front cover, close it.

If no dot drop-out or dot displacement occurs, this operation is finished. Tap  to go back to the original screen.

If dot drop-out or dot displacement is present, perform cleaning such as normal cleaning.

RELATED LINKS

- [P. 243 When Dot Drop-out or Dot Displacement Occurs](#)

Consumable Products and Parts Related to Manual Cleaning

The cleaning sticks, cleaning liquid, and print heads are consumable products or consumable parts.

- If you use up the cleaning sticks and cleaning liquid used for manual cleaning, contact your authorized Roland DG Corporation dealer or visit our website (<https://www.rolanddg.com/>).
- The print heads are components that wear out. Periodic replacement is required, with the frequency of replacement depending on use. Contact your authorized Roland DG Corporation dealer.

Disposing of Discharged Fluid

Precautions for Disposing of Discharged Fluid	239
If the Discharged Fluid Disposal Message Appears.....	240

Precautions for Disposing of Discharged Fluid

⚠ WARNING

Never place discharged fluid or ink near an open flame.
Doing so may cause a fire.

⚠ CAUTION

To store discharged fluid temporarily, place it in the included drain bottle or in a durable sealed container such as a metal can or polyethylene tank, and cap the container tightly.
Any spillage or vapor leakage may cause fire, odor, or physical distress.

IMPORTANT

Do not store discharged fluid in a location where it is exposed to direct sunlight.
When temporarily storing discharged fluid in the included drain bottle, do not store it in a location that is exposed to direct sunlight. The discharged fluid may harden, making the drain bottle unusable. The drain bottle may also deteriorate, leading to discharged fluid leaks.

IMPORTANT

Dispose of discharged fluid properly, in accordance with the laws in effect in your locale.
Discharged fluid is flammable and contains toxic ingredients. Never attempt to incinerate discharged fluid or discard it with ordinary trash. Also, do not dispose of it in sewer systems, rivers, or streams. Doing so may have an adverse impact on the environment.

If the Discharged Fluid Disposal Message Appears

The [When output, cleaning, and other operations are completed, discard the discharged fluid.] message appears when a certain amount of discharged fluid has collected in the bottle. If this message appears, dispose of the discharged fluid.

Procedure

1. When the message [When output, cleaning, and other operations are completed, discard the discharged fluid.] appears, tap [OK].

2. Tap  to display the notification.

3. Tap the following notification.

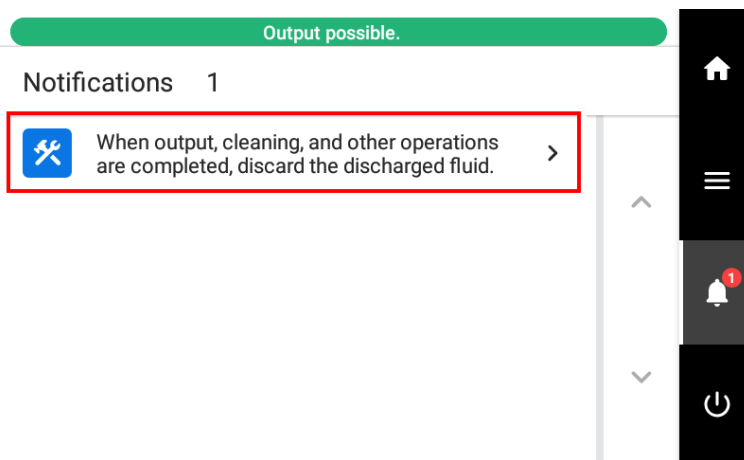

The [Drain Bottle] screen appears.

MEMO

You can dispose of discharged fluid even if the above message has not appeared. Use the following operations to display the drain bottle screen, and then dispose of discharged fluid according to the procedure starting from step 4.

1. Tap .
2. Tap [Maintenance]>[Drain Bottle].

4. Tap [Execute].

5. Remove the drain bottle and discard the discharged fluid.

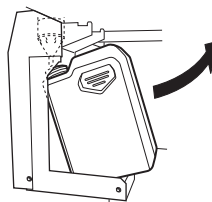

⚠ CAUTION

Before you detach the drain bottle, be sure to wait for the screen to display [Discard the discharged fluid in the bottle.]. After discarding the discharged fluid, promptly attach the drain bottle to the machine.

Failing to follow this procedure may cause discharged fluid to flow out of the tube and spill, soiling your hands or the floor.

IMPORTANT

When you remove the drain bottle, a few drops of discharged fluid may come out of the machine. Exercise caution to prevent this fluid from soiling your hands or the floor.

6. Quickly attach the emptied bottle to the machine once more.

7. Tap [Finish].

The display returns to the original screen.

8. Tap  to go back to the original screen.

Advanced Maintenance

When Dot Drop-out or Dot Displacement Occurs	243
Normal Cleaning Method	243
When Normal Cleaning Is Not Effective	244
Medium Cleaning Method	244
Powerful Cleaning Method	245
If Colors Are Uneven	246
Mixing the Ink by Shaking the Pouch Tray	246
Handling Severe Dot Drop-out and Dot Displacement	247
Ink Renewal Method	247
Partially Restricting the Print Heads Used for Printing	251
Emergency Measure) Cleaning the Print Head Surface	253
When the Operation Panel Is Dirty.....	254
Operation Panel Cleaning Method	254

When Dot Drop-out or Dot Displacement Occurs

If dot drop-out or dot displacement occurs, perform cleaning of the print heads (normal cleaning).

Normal Cleaning Method

Procedure

1. Tap .
2. Tap [Cleaning]>[Normal Cleaning].
3. Tap [Execute].
Cleaning will start. The status is displayed as [Normal cleaning in progress.] at the top of the operation panel.
On completion, you will return to the original screen.
4. Perform a printing test again.
5. Check to make sure the dot drop-out or dot displacement has been corrected.
If the problem persists, try performing normal cleaning again. If the printer has been used for a long period, dot drop-outs may not be fixed even after performing normal cleaning two or three times. If this is the case, clean using a different method.

RELATED LINKS

- [P. 117 Performing a Nozzle Drop-out Test](#)
- [P. 244 When Normal Cleaning Is Not Effective](#)

When Normal Cleaning Is Not Effective

Medium Cleaning Method

The print heads are important components that discharge ink. They require periodic and appropriate maintenance. When problems such as dot drop-out are not resolved by normal cleaning, perform the more forceful "medium cleaning" to remove clogging from the print heads.

IMPORTANT

Medium cleaning consumes more ink than normal cleaning, and overly frequent use may damage the print heads themselves. Avoid performing this operation more than necessary.

Procedure

1. Load the media.

[P. 30 Setup of New Media](#)

2. Tap .

3. Tap [Cleaning]>[Medium Cleaning].

4. Tap [Execute].

Cleaning will start. On completion, you will return to the original screen.

5. Tap .

6. Tap [Printing Test].

7. Select [Nozzle Drop-out Test] and tap [Execute].

Perform a printing test again to check whether the dot drop-out and dot displacement have been corrected.

MEMO

- If the problem persists, try performing medium cleaning again.
- If problems such as dot drop-out and dot displacement persist even after you have performed medium cleaning several times, perform "powerful cleaning."
- This cleaning can be effective when carried out periodically, according to the frequency of use.

RELATED LINKS

- [P. 245 Powerful Cleaning Method](#)

Powerful Cleaning Method

The print heads are important components that discharge ink. They require periodic and appropriate maintenance. When problems such as dot drop-out are not resolved by medium cleaning, perform the more forceful "powerful cleaning" to remove clogging from the print heads.

IMPORTANT

Powerful cleaning consumes more ink than medium cleaning, and overly frequent use may damage the print heads themselves. Avoid performing this operation more than necessary.

Procedure

1. Load the media.

[P. 30 Setup of New Media](#)

2. Tap .

3. Tap [Cleaning]>[Powerful Cleaning].

4. Tap [Execute].

Cleaning will start. On completion, you will return to the original screen.

5. Tap .

6. Tap [Printing Test].

7. Select [Nozzle Drop-out Test] and tap [Execute].

Perform a printing test again to check whether the dot drop-out and dot displacement have been corrected.

MEMO

- If the problem persists, try performing powerful cleaning again.
- This cleaning can be effective when carried out periodically, according to the frequency of use.
- If problems such as dot drop-out and dot displacement persist even after you have performed powerful cleaning several times, perform "manual cleaning."

RELATED LINKS

- [P. 231 Manual Cleaning Method](#)

If Colors Are Uneven

Mixing the Ink by Shaking the Pouch Tray

If ink components precipitate in the ink pouch, colors may be uneven (unevenness in printed colors). If colors are uneven, remove the pouch trays, and then shake them gently.

So that the ink mixes well, shake the pouch tray horizontally 50 times (about 20 seconds) with a stroke length of around 5 cm (2 in.) from each end of the tray.

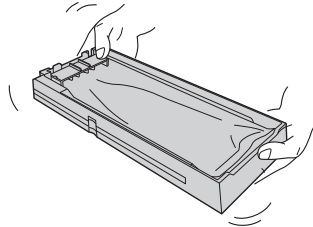

Shake the pouch trays once per week.

MEMO

To prevent ink precipitation, you can make the machine periodically display a message prompting you to mix the ink.
[P. 211 Showing/Hiding Notifications](#)

IMPORTANT

- Do not remove the ink pouches. Shake the entire pouch tray. Removing the ink pouches may lead to the ink leaking.
- Before shaking, wipe off any ink from around the mouth of the ink pouch. If you do not wipe off the ink, it may splatter when you shake the pouch tray.
- When you have finished mixing the ink, reinsert the pouch tray immediately. Taking time to reattach the ink cartridge will adversely affect the ink path.

If uneven color issues are not resolved even after shaking the pouch trays to mix the ink, perform **[Ink Renewal]**.

RELATED LINKS

- [P. 247 Ink Renewal Method](#)

Handling Severe Dot Drop-out and Dot Displacement

Ink Renewal Method

Perform "Ink Renewal" in the following situations.

- If ink discharge issues such as dot drop-out are not corrected after performing cleaning using the cleaning function (normal, medium, powerful) or manual cleaning.
- If uneven color issues are not resolved even after shaking the pouch trays to mix the ink.

IMPORTANT

A large amount of ink will be discharged during ink renewal. Perform this operation only when ink discharge issues such as dot drop-out, dot displacement, and uneven colors cannot be corrected even after performing cleaning using the other cleaning functions (normal, medium, powerful, and manual).

RELATED LINKS

- [P. 243 When Dot Drop-out or Dot Displacement Occurs](#)
- [P. 244 Medium Cleaning Method](#)
- [P. 245 Powerful Cleaning Method](#)
- [P. 231 Manual Cleaning Method](#)

1. Start the [Ink Renewal] menu.

Procedure

1. Tap .
2. Tap [Maintenance]>[Ink Renewal].
3. Tap [Execute].
The [Discard the discharged fluid in the bottle.] screen appears.
4. Remove the drain bottle and discard the discharged fluid.

IMPORTANT

When you remove the drain bottle, a few drops of discharged fluid may come out of the machine. Exercise caution to prevent this fluid from soiling your hands or the floor.

CAUTION

Before you detach the drain bottle, be sure to wait for the screen to display [Discard the discharged fluid in the bottle.]. After discarding the discharged fluid, promptly attach the drain bottle to the machine.

Failing to follow this procedure may cause discharged fluid to flow out of the tube and spill, soiling your hands or the floor.

WARNING

Never place discharged fluid or ink near an open flame.

Doing so may cause a fire.

CAUTION

To store discharged fluid temporarily, place it in the included drain bottle or in a durable sealed container such as a metal can or polyethylene tank, and cap the container tightly.

Any spillage or vapor leakage may cause fire, odor, or physical distress.

IMPORTANT

Do not store discharged fluid in a location where it is exposed to direct sunlight.

When temporarily storing discharged fluid in the included drain bottle, do not store it in a location that is exposed to direct sunlight. The discharged fluid may harden, making the drain bottle unusable. The drain bottle may also deteriorate, leading to discharged fluid leaks.

IMPORTANT

Dispose of discharged fluid properly, in accordance with the laws in effect in your locale.

Discharged fluid is flammable and contains toxic ingredients. Never attempt to incinerate discharged fluid or discard it with ordinary trash. Also, do not dispose of it in sewer systems, rivers, or streams. Doing so may have an adverse impact on the environment.

5. Quickly attach the emptied drain bottle to the machine once more.

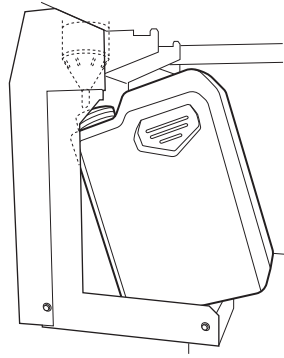

6. Tap [Finish].
Ink renewal starts. On completion, you will return to the original screen.
7. Tap  to go back to the original screen.

2. Perform a printing test to check the results.

Procedure

1. Load the media.

P. 30 Setup of New Media

2. Tap  [Nozzle Drop-out Test] on the home screen.

3. Tap [Execute] next to [Printing Test].
Printing of the test pattern starts.

4. Check whether there is dot drop-out or dot displacement in the test pattern and whether its uneven colors have been eliminated.

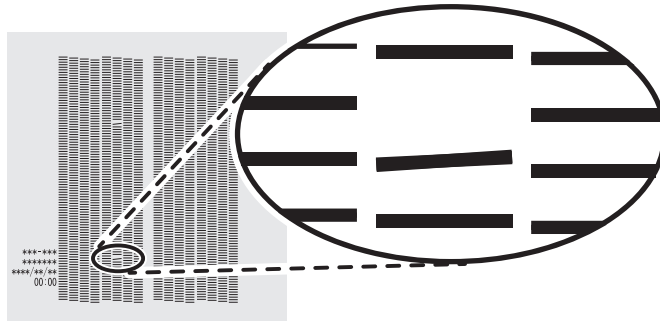

5. If you have opened the front cover, close it.

If no dot drop-out or dot displacement occurs and if there are no uneven colors, this operation is finished. Tap  to go back to the original screen.

If the dot drop-out or dot displacement location is different, perform medium cleaning another two or three times.

If this problem is not fixed, contact your authorized Roland DG Corporation dealer.

Partially Restricting the Print Heads Used for Printing

When dot drop-out or dot displacement is not improved even after renewing the ink, partially restrict the print heads to use for printing. This operation is called the "nozzle mask," and while it slows down printing speed, it also allows you to decrease the impact of dot drop-out or dot displacement.

First print a test pattern, and then select the nozzle group to use by viewing the test results. After that, use VersaWorks to select the nozzle group used for printing.

1. Perform a printing test for the nozzle mask.

Procedure

1. Load the media.

P. 30 Setup of New Media

2. Tap .

3. Tap [Cleaning]>[Printing Test].

4. Select [Nozzle Mask Test] and tap [Execute].

Printing of the test pattern starts.

5. Check for the nozzle group with dot drop-out or dot displacement by viewing the results of the printing test.

The results of the printing test are displayed separately for nozzle groups "1," "2," and "3." The following shows dot drop-outs in nozzle groups "1" and "3."

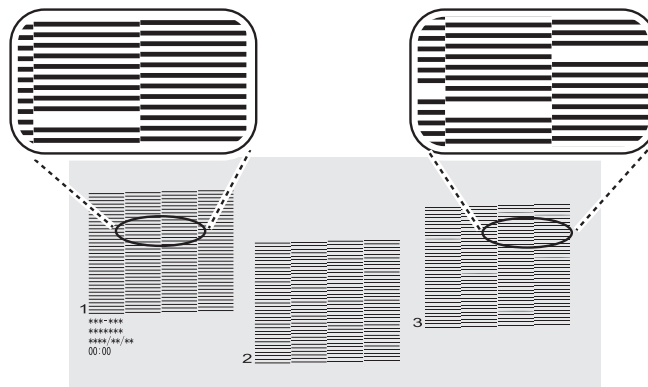

MEMO

If the printing-test results are difficult to interpret

Check the results in a bright location, changing your line of vision. They are visible using the reflection of the light.

6. If you have opened the front cover, close it.

If no dot drop-out or dot displacement occurs, this operation is finished. Tap  to go back to the original screen.

2. Limit the print heads used for printing.

Procedure

1. Start VersaWorks.
2. Click [Printer]>[Printer Settings].
The [Printer Settings] dialog box appears.
3. From the [Printer List], select the printer whose print heads will be limited.
4. Click [Advanced].
The [Advanced] dialog box appears.
5. Select the nozzle group to use in printing from the printing-test results.
The nozzle group numbers that can be selected vary depending on the model being used and the firmware version. Select the appropriate group number (or all the group numbers) to match the results of the printing test.

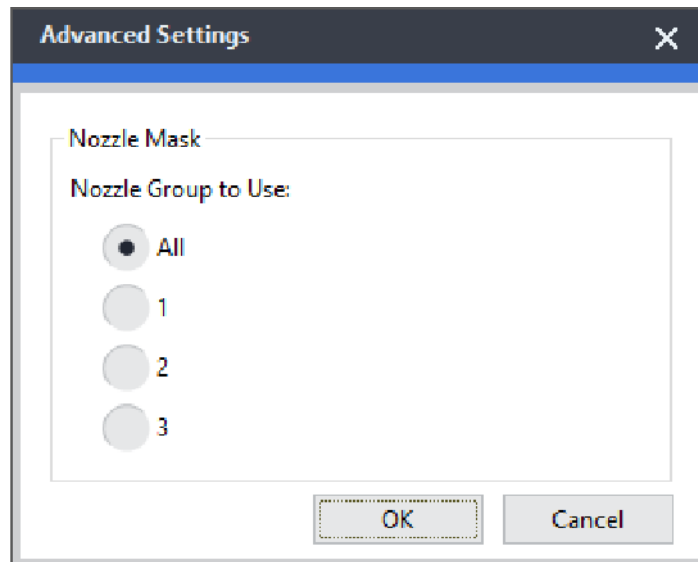

6. Click [OK].
Close the [Advanced] dialog box.
7. Click [OK].
Close the [Printer Settings] dialog box.
The  icon is displayed on top of the image of the printer whose setting has been changed.

RELATED LINKS

- VersaWorks manual (<https://downloadcenter.rolanddg.com/VersaWorks6>)

Emergency Measure) Cleaning the Print Head Surface

When dot drop-out or dot deflection is not improved even if cleaning is performed several times, you can clean the surface of the print heads as an emergency measure. The print head surface (nozzle surface) is a very delicate mechanism, so work must be performed carefully and cautiously.

This operation is an emergency measure. It may damage defect-free parts depending on the symptoms, worsening the symptoms. If you have any questions, contact your authorized Roland DG Corporation dealer.

Procedure

1. Apply a large amount of cleaning liquid to the cleaning stick.
2. Very gently touch the cleaning stick against the print head surface (nozzle surface).
Very softly press the cleaning stick against the print head so that cleaning liquid soaks into the print head surface (nozzle surface). Never rub the stick on the surface or press it forcibly.

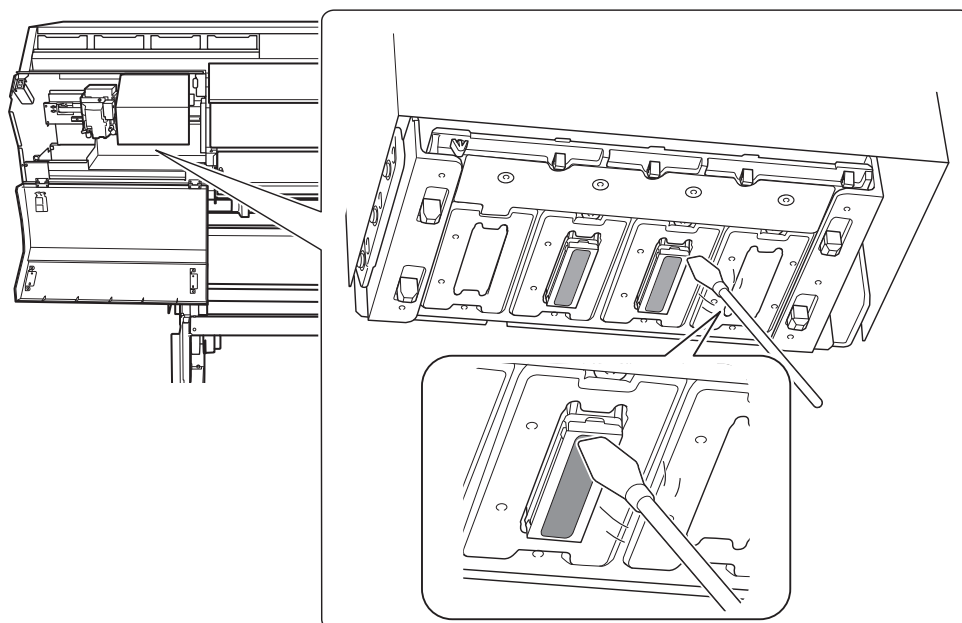

When the Operation Panel Is Dirty

Operation Panel Cleaning Method

IMPORTANT

Important notes on this procedure

- The cloths, alcohol, and similar items used in cleaning are not included with the product.
- Be sure to use a cloth when cleaning the operation panel. Liquid entering into the operation panel through its gaps may cause printer malfunctions.

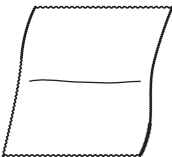
Required items	
	
Anhydrous ethanol or isopropyl alcohol	Cloth (that is not fluffy)

⚠ CAUTION

When using anhydrous ethanol or isopropyl alcohol, be sure to follow the product's usage precautions.

Exercise caution regarding items such as fire, ventilation, and rashes.

⚠ CAUTION

Only use anhydrous ethanol or isopropyl alcohol.

Using chemicals (or similar substances) other than anhydrous ethanol or isopropyl alcohol may lead to operation panel damage.

Procedure

1. Wipe off the operation panel with a cloth soaked in anhydrous ethanol or isopropyl alcohol.
Wipe slowly and gently to remove the grime.

Replacing Consumable Parts

Replacing Parts for Maintenance	256
Replacing the Wiper and the Tray Pad	256
Cleaning the Wiper Tray.....	259
Replacing the Blade/Separating Knife.....	262
Replacing the Blade.....	262
Replacing the Separating Knife	269

Replacing Parts for Maintenance

Replacing the Wiper and the Tray Pad

The wipers and the tray pads are components that are used for cleaning the print heads.



When it is time to replace the wiper, the message [The time for wiper replacement has arrived.] appears. In this situation, replace the wiper and tray pad.

For information about purchasing wipers or tray pads, contact your authorized Roland DG Corporation dealer or visit our website (<https://www.rolanddg.com/>).

⚠ WARNING

Be sure to perform operations as specified by the instructions, and never touch any area not specified in the instructions.

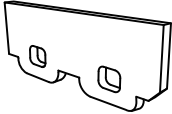
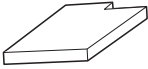
Sudden movement of the machine may cause injury.

Required items		
		
Wiper	Tray pad	Tweezers

Procedure

1. When the message [The time for wiper replacement has arrived.] appears, tap [OK].

2. Remove any media.

3. Tap  to display the messages.

4. Tap [The time for wiper replacement has arrived.].

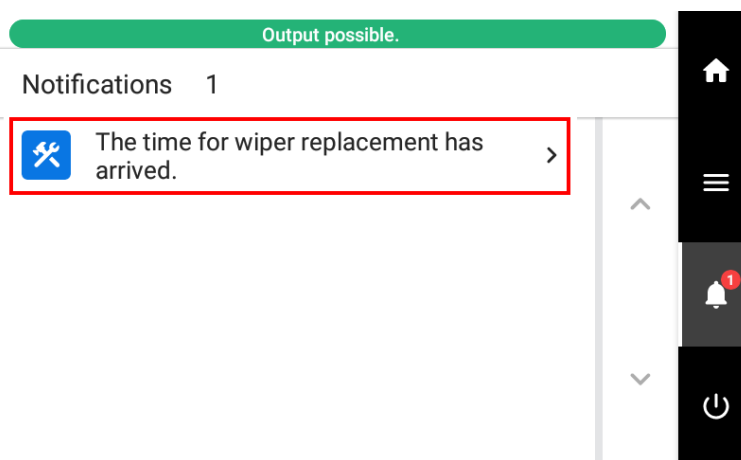

The [Wiper Replacement] screen appears.

5. Tap [Execute].

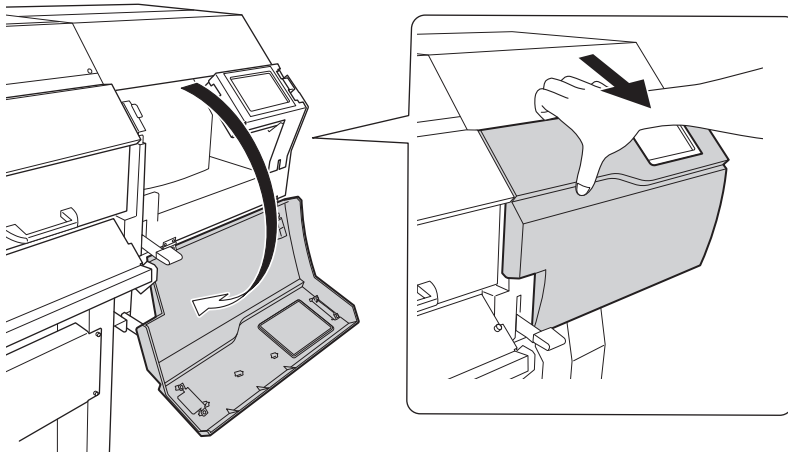

The cutting carriage moves to a location where wiper replacement is possible.

6. When [Open the right cover.] appears, open the right cover.



MEMO

The procedure is displayed on the operation panel.

- Tap  or  to check the procedure.
- If you complete the work without viewing the instructions, tap [Finish All].

7. Touch the location shown in the figure to discharge any static electricity.

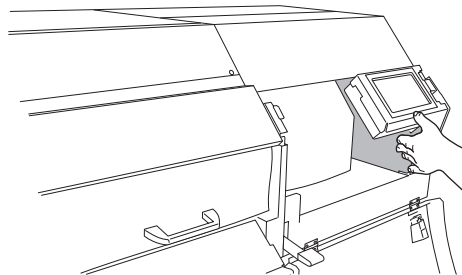

8. Replace the wipers.

- (1) Detach the old wipers.

Using the tweezers, unhook the wipers, and then pull them up. Using the tweezers to press on the hook in the hole on the wiper makes it easier to remove the wiper.

- (2) Attach the new wipers.

Place the inclined end of the wiper on the back side of the machine. If the wiper is installed with the incorrect orientation, appropriate cleaning will not be possible.

Be sure to attach the wiper to the hook. Failure to do so may result in dot drop-out or other problems.

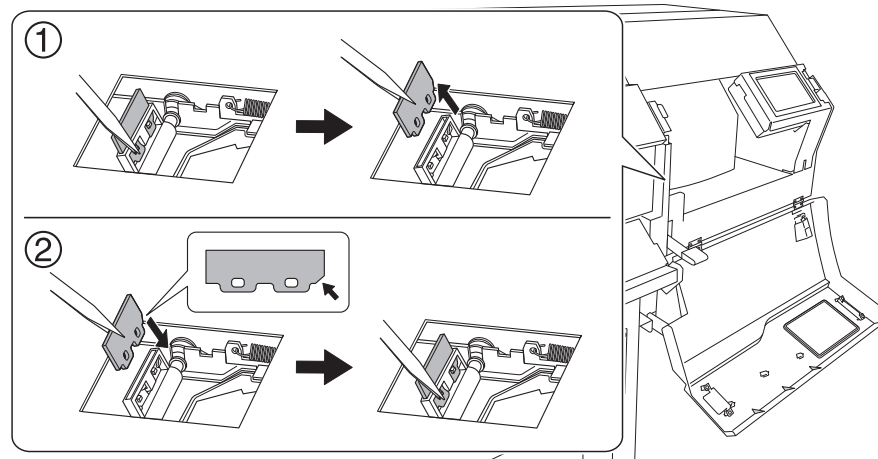

9. Replace the tray pad.

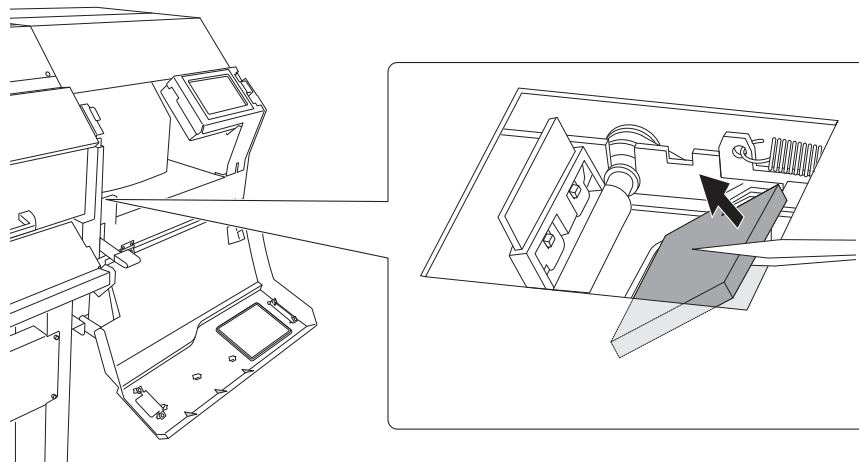

IMPORTANT

Place the tray pad with an orientation that matches the shape of the wiper tray. If you place the tray pad with the incorrect orientation, it will not be possible to clean the wiper correctly.

10. When the replacement of the wiper and tray pad is complete, tap [Finish All].

11. When [Close the cover.] appears, close the right cover.

When you close the right cover, you are returned to the original screen.

12. Tap  to go back to the original screen.

Cleaning the Wiper Tray

Discharged fluid collects in the wiper tray. The wiper tray must be cleaned periodically.

When it is time to clean the wiper tray, the message [The time for wiper tray cleaning has arrived.] appears. When this message is displayed, clean the wiper tray.

⚠ WARNING

Be sure to perform operations as specified by the instructions, and never touch any area not specified in the instructions.

Sudden movement of the machine may cause injury.

Procedure

1. When the message [The time for wiper tray cleaning has arrived.] appears, tap [OK].

2. Tap  to display the messages.

3. Tap [The time for wiper tray cleaning has arrived.].

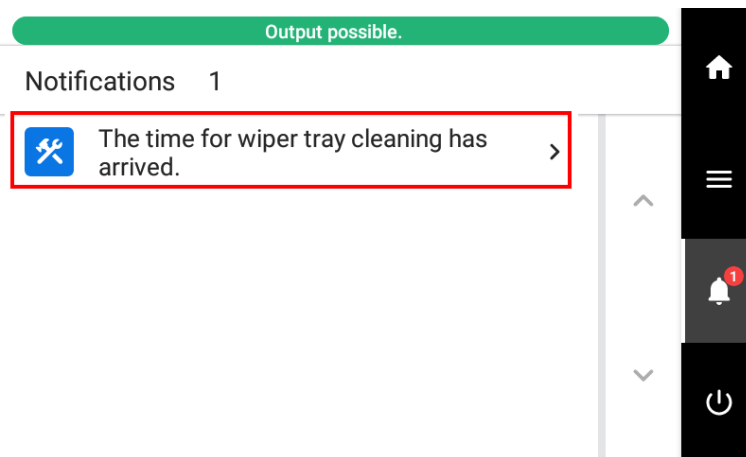

The [Wiper Tray Cleaning] screen appears.

4. Tap [Execute].

When the message [Discard the discharged fluid in the bottle.] appears, use the following procedure to discard the discharged fluid.

- (1) Detach the drain bottle.

IMPORTANT

When you remove the drain bottle, a few drops of discharged fluid may come out of the machine. Exercise caution to prevent this fluid from soiling your hands or the floor.

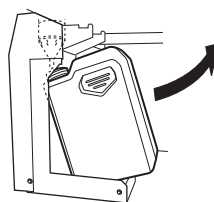

- (2) Empty the bottle by discarding the discharged fluid.
- (3) Quickly attach the emptied bottle to the machine once more.
- (4) Tap [Finish].

⚠ CAUTION

Before you detach the drain bottle, be sure to wait for the screen to display [Discard the discharged fluid in the bottle.]. After discarding the discharged fluid, promptly attach the drain bottle to the machine.

Failing to follow this procedure may cause discharged fluid to flow out of the tube and spill, soiling your hands or the floor.

⚠ WARNING

Never place discharged fluid or ink near an open flame.

Doing so may cause a fire.

⚠ CAUTION

To store discharged fluid temporarily, place it in the included drain bottle or in a durable sealed container such as a metal can or polyethylene tank, and cap the container tightly.

Any spillage or vapor leakage may cause fire, odor, or physical distress.

IMPORTANT

Do not store discharged fluid in a location where it is exposed to direct sunlight.

When temporarily storing discharged fluid in the included drain bottle, do not store it in a location that is exposed to direct sunlight. The discharged fluid may harden, making the drain bottle unusable. The drain bottle may also deteriorate, leading to discharged fluid leaks.

IMPORTANT

Dispose of discharged fluid properly, in accordance with the laws in effect in your locale.

Discharged fluid is flammable and contains toxic ingredients. Never attempt to incinerate discharged fluid or discard it with ordinary trash. Also, do not dispose of it in sewer systems, rivers, or streams. Doing so may have an adverse impact on the environment.

Wiper tray cleaning starts.

IMPORTANT

An error will be displayed in the situations shown below. Eliminate the cause of the error, and then tap [Execute] again.

- When the machine runs out of cleaning liquid
- When no cleaning liquid cartridge has been inserted

When the discharging of the liquid in the wiper tray is complete, the tray is filled with cleaning liquid. [Cleaning liquid filling in progress.] and the (approximate) remaining time are displayed at the top of the operation panel.

If the cleaning liquid runs out during filling, [Unable to Fill Wiper Cleaning Liquid] is displayed at the top of the operation panel. Replace the cleaning liquid pouch.

[P. 113 Cleaning Liquid Pouch Replacement](#)

5. Tap  to go back to the original screen.

Replacing the Blade/Separating Knife

Replacing the Blade

If the blade becomes dull, if the edge of the blade is chipped, or if the cutting quality is lowered, replace the blade with a new blade.

⚠ WARNING

Be sure to perform operations as specified by the instructions, and never touch any area not specified in the instructions.

Sudden movement of the machine may cause injury.

⚠ CAUTION

Never touch the tip of the knife.

Doing so may result in injury. The cutting performance of the blade will also be impaired.

Required item

Replacement blade



1. Replacing the Blade

Procedure

1. Remove any media.
2. Tap .
3. Tap [Maintenance]>[Blade Replacement].
The [Blade Replacement] screen appears.
4. Tap [Execute].
The cutting carriage moves to a position where blade replacement is possible.
5. When [Open the front cover.] appears, open the front cover.

MEMO

The procedure is displayed on the operation panel.

- Tap  or  to check the procedure.
- If you complete the work without viewing the instructions, tap [Finish All].

6. Detach the blade holder.

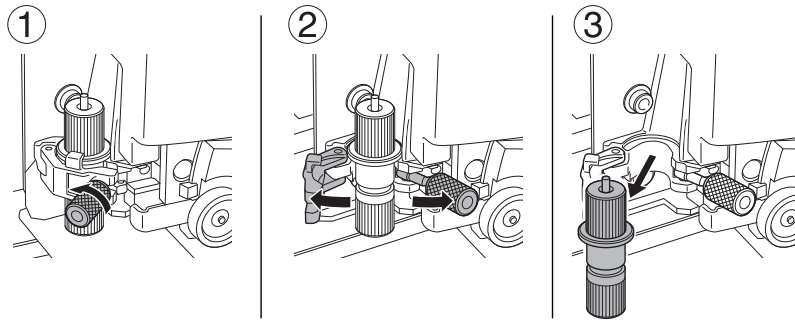

7. Replace the blade.

- (1) Press the pin (A) to push out the old blade (B).
- (2) Insert a new blade (C).
- Orient the tip of the blade (D) correctly.

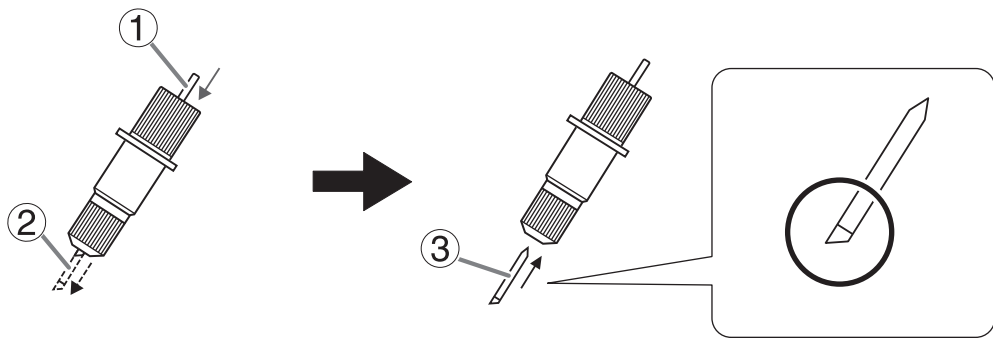

8. Install the blade holder into the cutting carriage.

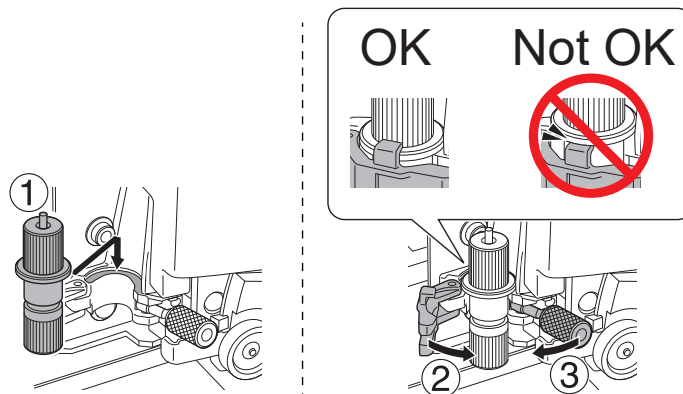

9. Tighten the screw.

Tug the blade holder upward to make sure it does not come loose.

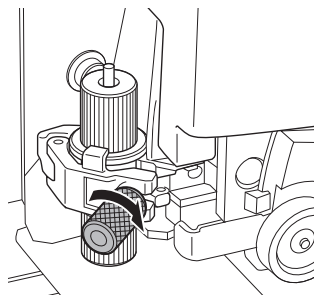

10. When the replacement of the blade is complete, tap [Finish All].

11. When [Close the cover.] appears, close the front cover.
When you close the front cover, you are returned to the original screen.





12. Tap  to go back to the original screen.

2. Make adjustments according to the new blade.

Procedure

1. Load the media.

2. Tap  [Move].

3. Hold down  ,  ,  , or  to move the cutting carriage to the location where you want to carry out the cutting test.

You can freely set the location for the cutting test.

4. Tap [Set Base Point Here].

You are returned to the home screen.

5. Tap .

6. Tap [Media Settings]>[Cutting Settings]>[Blade Adjustment].

7. Tap [Execute] next to [Cutting Test].

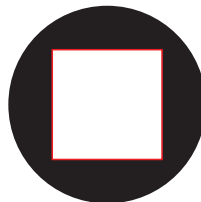

The test pattern is cut.

8. Check the results of the cutting test.



Check item	Result	Setting item	Adjustment
Check the shape.	The cut shape is distorted.	[Cutting Speed]	Reduce
Peel off the circle.	The square also peels off.	[Blade Force]	Increase
	Some uncut areas remain.	[Cutting Speed]	Reduce
Peel off the square.	The blade leaves faint traces on the backing paper.	[Blade Force]	No change
	The blade trace is indistinct.		Increase
	The blade trace is too deep and cuts into the backing paper.		Reduce

Replacing the Blade/Separating Knife

Check item		Result	Setting item	Adjustment
Check the shape of the square you have peeled off.		The corners are not rounded and do not have "horns."	[Blade Offset]	No change
		The corners are rounded.		Increase
		The corners have "horns."		Reduce

9. Tap  or  to change the settings.

Cutting condition	Setting details	Default settings
[Blade Force]	Set the force (pressure) of the blade.	50 gf
[Cutting Speed]	Set the speed of cutting.	30 cm/s
[Blade Offset]	Set the blade offset. Enter the listed offset value for the blade. The offset value for the included blade is 0.250 mm (9.8 mil).	0.250 mm (0.010 in.)
[Rise Movement Speed]	Set the blade's up speed during cutting (the speed at which the blade travels when it moves to the next cutting line after cutting one cutting line). If the media comes loose during no-load feed and the blade damages the surface of the media, reduce the speed.	30 cm/s

10. Press [Save] to confirm your entry.
11. Repeatedly perform the cutting test and adjust the cutting conditions until the settings are optimized. Repeat steps 8 to 11 to adjust the cutting conditions.
12. Tap  to go back to the original screen.

3. Accurately Adjusting the Cutting-in Amount

When you want to perform accurate and fine adjustment of the cutting-in amount, such as when cutting media with thin backing paper, you can obtain good results by adjusting the amount of blade extension. Turn the cap portion of the blade holder to adjust the amount of blade extension. Each indicator tick corresponds to 0.1 mm (3.9 mil), and adjustment for 0.5 mm (19.7 mil) can be made by rotating the cap one full turn.

Note that making the amount of blade extension too small may cause the tip of the blade holder cap to touch the printed surface, soiling and damaging it. It is important to be especially careful about this when you are using media that has poor ink-adhesion properties.

The amount of blade extension (A) is 0 mm (0 in.) at minimum and 2.5 mm (98.42 mil) (C) at maximum.

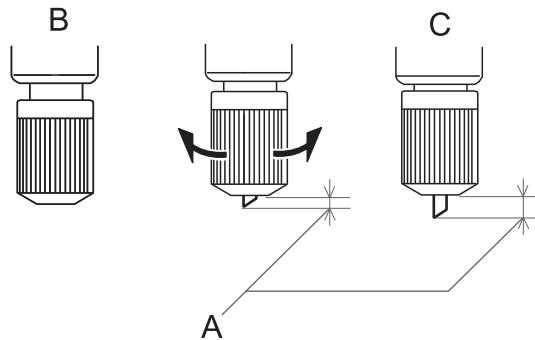

- **Rough Estimate for the Amount of Blade Extension (When Creating a Sticker)**

Set the amount of blade extension (A) to an amount that is the sum of the thickness of the material portion (B) and half (D) the thickness of the backing paper (C).

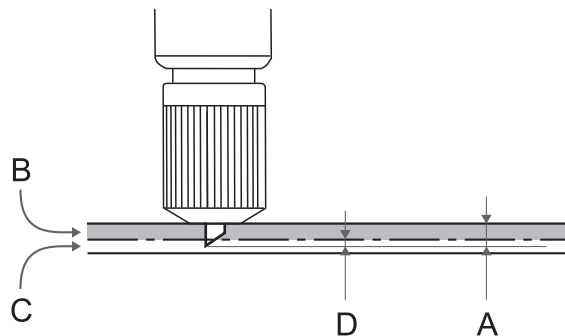

- **Rough Estimate for the Amount of Blade Extension (When Cutting Perforated Lines)**

Set the amount of blade extension (A) so that when the blade pierces the media (B), the blade tip extends slightly.

For information about the output settings for cutting perforated lines, refer to the documentation for VersaWorks.

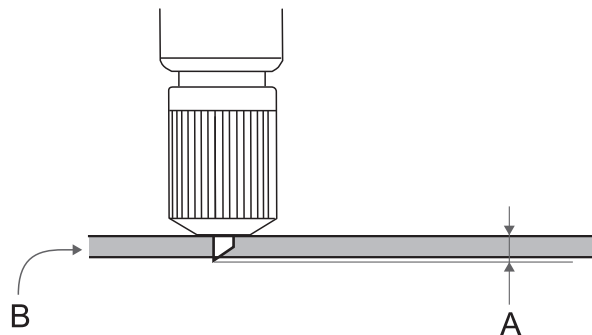

IMPORTANT

Pushing the blade out too far will damage the blade and blade protector and hasten their deterioration, so exercise caution.

Replacing the Separating Knife

If the separating knife becomes dull, replace it with the included replacement knife.

⚠ WARNING

Be sure to perform operations as specified by the instructions, and never touch any area not specified in the instructions.

Sudden movement of the machine may cause injury.

⚠ CAUTION

Do not touch the tip of the separating knife.

Doing so may result in injury.

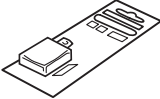

Required item

Replacement blade for separating knife

Procedure

1. Remove any media.
2. Tap .
3. Tap [Maintenance]>[Separating Knife Replacement].
The [Separating Knife Replacement] screen appears.
4. Tap [Execute].
The cutting carriage moves to a position where separating knife replacement is possible.
5. When [Open the front cover.] appears, open the front cover.

MEMO

The procedure is displayed on the operation panel.

- Tap  or  to check the procedure.
- If you complete the work without viewing the instructions, tap [Finish All].

6. Remove the separating knife.
 - (1) Loosen the screw until it slips out.
 - (2) Grasp the screw portion, and slowly pull in the direction of the arrow.
When doing this, do not pull it back toward you.

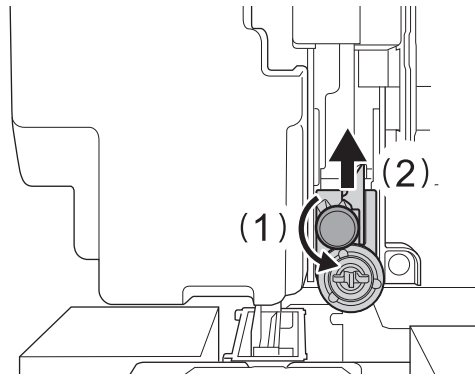

7. Install a new knife.

Slide the knife, as far as it will go, to align it with the groove.

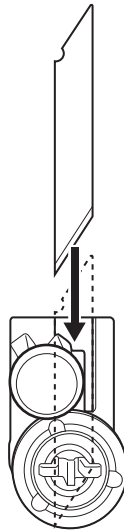

8. Slowly insert the knife into the groove (A).

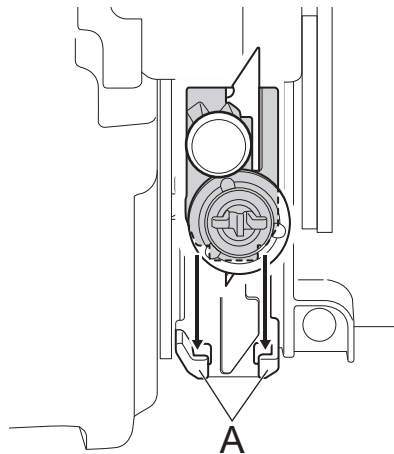



9. Tighten the screw.

Take care to ensure that the knife does not slip out of position at this time.

MEMO

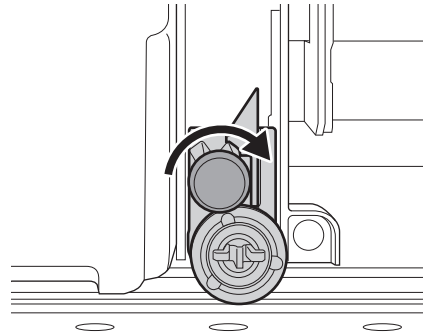
Do not overtighten the screw.



10. When the separating knife replacement is finished, tap [Finish All].
11. When [Close the cover.] appears, close the front cover.
When you close the front cover, you are returned to the original screen.
12. Tap  to go back to the original screen.

Troubleshooting Methods

Output Quality Problems

Printed results are coarse or contain horizontal stripes.....	274
Do the print heads cause dot drop-out?	274
Is the print head height appropriate?	274
Have you carried out [Feed Correction] ?	274
Have you carried out [Media Gap Adjustment] (ink landing position correction)?.....	274
Is the printer installed in a level and stable location?	275
Is the media heating system at a suitable temperature?	275
Is the temperature of the room too low?.....	275
Is the print mode suitable?	275
Is the media loaded correctly?	275
Are the [Media Settings] appropriate?	275
The media becomes soiled when printed	276
Do the print heads come into contact with the media?.....	276
Are the print heads dirty?.....	276
Are the pinch rollers or the media clamps dirty?	276
Colors are unstable or uneven.....	277
Have you tried mixing the ink by shaking the pouch trays?	277
Are colors still uneven after mixing the ink by shaking the pouch trays?	277
Is the media wrinkled?	277
Was printing paused partway through?	277
Is the printer installed in a level and stable location?	277
Is the media loaded correctly?	277
Are the operating parameters set to appropriate values?	278
Are the [Media Settings] appropriate?	278
Cutting Is Misaligned, Skewed, or Not Clean	279
Is the media loaded correctly?	279
Are the settings for the cutting conditions appropriate?	279
Is the length of output too long?.....	279
Are you using media that exhibits large expansion and contraction?	279
Is the setting for the [Cutting Distance Correction] menu item (under [Cutting Settings]) correct?	279
Are the pinch rollers placed on the proper locations?.....	280
Have you corrected the misalignment of printing and cutting?.....	280
Is the blade holder installed appropriately?	280
Is the blade worn?.....	280
Is there any buildup of pieces of material or dust inside the blade holder?	280

Printed results are coarse or contain horizontal stripes

Do the print heads cause dot drop-out?

Carry out a printing test and make sure no dot drop-out or dot displacement occurs. If dot drop-out or dot displacement is present, perform head cleaning.

RELATED LINKS

- [P. 117 Performing a Nozzle Drop-out Test](#)
- [P. 118 Normal Cleaning Method](#)
- [P. 244 When Normal Cleaning Is Not Effective](#)

Is the print head height appropriate?

Printing when the [Print Head Height] menu item is set to [High] or to [Medium] is coarser than when set to [Low]. Keep this set to [Low] except when changing it is necessary, such as when you are using thick media.

RELATED LINKS

- [P. 153 Changing the Print Head Height](#)

Have you carried out [Feed Correction]?

Large misalignment in the amount of feed of the media may result in printing that seems coarse or contains horizontal bands. Either make the setting in the software RIP to match the type of media you are using, or make the setting for correction on the printer.

RELATED LINKS

- [P. 148 Automatically Making Required Adjustments](#)
- [P. 149 Manual Adjustment: Reducing Horizontal Bands \(Feed Correction Function\)](#)

Have you carried out [Media Gap Adjustment] (ink landing position correction)?

The optimal adjustment value varies depending on the thickness of the media. Set an adjustment value that is suitable for the media. When further correction is required, such as when adjustment made using [Simple Correction (Auto)] does not enhance printing, use [Detailed Correction (Manual)] to make the correction.

RELATED LINKS

- [P. 148 Automatically Making Required Adjustments](#)
- [P. 151 Manual Adjustment: Adjusting the Misalignment of the Ink Landing Position \(Media Gap Adjustment\)](#)

Is the printer installed in a level and stable location?

Never install the machine in a location where it is tilted or where it may wobble or experience vibration. Also make sure that the print heads are not exposed to moving air. These factors may lead to dot drop-out or reduced printing quality.

Is the media heating system at a suitable temperature?

If the ink forms lumps or smudges, raise the temperature. Note, however, that a temperature that is too high may degrade the media or cause it to wrinkle.

RELATED LINKS

- [P. 164 Changing the Print Heater Temperature](#)
- [P. 166 Changing the Dryer Temperature](#)

Is the temperature of the room too low?

The media heating system may not warm up sufficiently when the ambient temperature is less than 20°C (68°F). Also, even when the media heating system reaches its set temperatures, adequate effectiveness may not be apparent if the media is thoroughly chilled. Before printing, allow the media to come to room temperature.

Is the print mode suitable?

If attractive printing is impossible even when the media heating system is at a high temperature, try using a higher-quality print mode. Depending on the media, smudging may occur when using a high-quality print mode, and results may also vary greatly depending on the settings of your software RIP (such as the color-profile selection). Select settings appropriate for the media you are using.

Is the media loaded correctly?

If the media is not loaded correctly or the media feed is not smooth, output may be adversely affected. Load the media correctly.

RELATED LINKS

- [P. 30 Setup of New Media](#)
- [P. 67 Setup of Registered Media](#)

Are the [Media Settings] appropriate?

If the settings are not suitable for the type of media, printing may be adversely affected. Choose settings optimized for the media you are using.

RELATED LINKS

- [P. 195 Changing the Media Settings](#)

The media becomes soiled when printed

Do the print heads come into contact with the media?

The height of the print heads may be too low. Also, if the media is not loaded and set up correctly, it may wrinkle or come loose and contact the print heads.

RELATED LINKS

- [P. 153 Changing the Print Head Height](#)
- [P. 30 Setup of New Media](#)
- [P. 67 Setup of Registered Media](#)

Are the print heads dirty?

The following may cause ink to drip on the media during printing.

- Buildup of fibrous dust (lint) around the heads
- Ink transferred to the heads due to rubbing against the media

If this happens, perform manual cleaning. We recommend carrying out periodic head cleaning.

- Too low humidity

Use the machine in an environment where the humidity is 35 to 80%RH (no condensation).

RELATED LINKS

- [P. 230 Cleaning around the Print Heads](#)

Are the pinch rollers or the media clamps dirty?

Periodically clean them.

RELATED LINKS

- [P. 228 Cleaning the Machine](#)

Colors are unstable or uneven

Have you tried mixing the ink by shaking the pouch trays?

If colors are uneven, remove the pouch trays, and then shake them 50 times (for approximately 20 seconds).

RELATED LINKS

- [P. 246 Mixing the Ink by Shaking the Pouch Tray](#)

Are colors still uneven after mixing the ink by shaking the pouch trays?

If uneven color issues with ink occur even after shaking the pouch tray to mix the ink, perform "Ink Renewal."

RELATED LINKS

- [P. 247 Ink Renewal Method](#)

Is the media wrinkled?

If the media is wrinkled and comes loose from the platen, colors may be uneven or the printing quality may suffer.

RELATED LINKS

- [P. 30 Setup of New Media](#)
- [P. 67 Setup of Registered Media](#)

Was printing paused partway through?

When printing is paused, the coloring at the seam may be altered when printing resumes. Avoid pausing printing. Before you perform lengthy printing, check the amount of ink remaining in the ink pouches. Printing may also pause when data is not sent from the computer quickly enough. We recommend not performing any other tasks with the computer while printing is in progress.

Is the printer installed in a level and stable location?

Never install the machine in a location where it is tilted or where it may wobble or experience vibration. Also make sure that the print heads are not exposed to moving air. These factors may lead to dot drop-out or reduced printing quality.

Is the media loaded correctly?

If the media is not loaded correctly or the media feed is not smooth, output may be adversely affected. Load the media correctly.

RELATED LINKS

- [P. 30 Setup of New Media](#)

- [P. 67 Setup of Registered Media](#)

Are the operating parameters set to appropriate values?

Depending on the settings for such menu items as [Printing Movement Range] and [Cleaning during Printing], uneven colors may occur. If the settings have been changed, try restoring them to their default values.

RELATED LINKS

- [P. 204 Speeding Up Output for Narrow Media](#)
- [P. 160 Preventing Soiling of the Media, Dot Drop-out, and Dot Displacement](#)

Are the [Media Settings] appropriate?

If the settings are not suitable for the type of media, printing may be adversely affected. Choose settings optimized for the media you are using.

RELATED LINKS

- [P. 195 Changing the Media Settings](#)

Cutting Is Misaligned, Skewed, or Not Clean

Is the media loaded correctly?

If the media is not loaded correctly or the media feed is not smooth, output may be adversely affected. Load the media correctly.

RELATED LINKS

- [P. 30 Setup of New Media](#)
- [P. 67 Setup of Registered Media](#)

Are the settings for the cutting conditions appropriate?

Misalignment or skewing may occur if the cutting speed is too fast or the blade force is too high. Try changing the cutting conditions. With media having a strong adhesive layer, the adhesive layer reattaches to itself immediately after cutting. However, if a cutting test shows that the peeling of the media and the blade traces on the backing paper are optimal, the media is being cut properly. Be careful not to make the blade force too high.

RELATED LINKS

- [P. 173 Accurately Adjusting the Cutting Settings](#)

Is the length of output too long?

For printing followed immediately by cutting in particular, the longer the page length (that is, the longer the distance the media is returned after printing), the greater the chance of misalignment occurring. It is a good idea to keep the size of each single page to the minimum necessary.

Are you using media that exhibits large expansion and contraction?

When you are performing printing followed immediately by cutting, misalignment occurs if the media expands or contracts. If this happens, try performing printing with crop marks followed by cutting. The cutting position will be corrected to match the expansion and contraction of the media.

RELATED LINKS

- [P. 134 How to Cut with Crop Marks](#)

Is the setting for the [Cutting Distance Correction] menu item (under [Cutting Settings]) correct?

When you are performing printing followed immediately by cutting, go to [Cutting Settings] and set the [Cutting Distance Correction] correction value to 0.00%.

RELATED LINKS

- [P. 177 Performing Distance Correction during Cutting](#)

Are the pinch rollers placed on the proper locations?

Be sure to place the pinch rollers on the grit rollers. If the pinch rollers are not placed on the proper locations, misalignment of the media may occur.

RELATED LINKS

- [P. 30 Setup of New Media](#)
- [P. 67 Setup of Registered Media](#)

Have you corrected the misalignment of printing and cutting?

Misalignment between the printing and cutting positions may occur due to the thickness of the media or the head height. Make corrections for misaligned printing and cutting for the media you are using.

RELATED LINKS

- [P. 181 Accurately Adjusting the Settings for Printing and Cutting](#)

Is the blade holder installed appropriately?

When installing the blade holder, firmly tighten the screw and check that the blade holder is fixed in place.

RELATED LINKS

- [P. 262 Replacing the Blade](#)

Is the blade worn?

A worn or chipped blade will negatively affect the cutting quality. Check the status of the blade and replace it with a new one if necessary.

RELATED LINKS

- [P. 262 Replacing the Blade](#)

Is there any buildup of pieces of material or dust inside the blade holder?

Remove the blade holder, and then take off the tip of the blade holder and remove any pieces of material or dust inside.

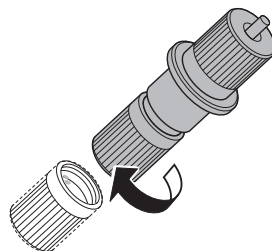

After cleaning, adjust the amount of blade extension.

RELATED LINKS

- [P. 175 Accurately Adjusting the Cutting-in Amount](#)

Problems in Cutting with Crop Marks

Automatic Detection of Crop Marks Fails	283
Is the media wrinkled or warped?	283
Is the media size too large?.....	283
Are you using media that is likely to reflect light or has deep colors?	283
Are you using transparent media?	283
Printing and Cutting Are Misaligned	284
Have you corrected the misalignment of printing and cutting with crop marks?	284

Automatic Detection of Crop Marks Fails

Is the media wrinkled or warped?

Wrinkled or warped media may cause crop mark detection to fail. Avoid using wrinkled or warped media.

RELATED LINKS

- [P. 193 Correcting the Reading Sensor](#)

Is the media size too large?

Large media may lead to large errors, which may cause crop mark detection to fail.

When you want to use lengthy media, we recommend performing output with the data separated into sizes that are as short as possible.

Are you using media that is likely to reflect light or has deep colors?

The machine may not be able to read crop marks printed on media that is likely to reflect light or has deep colors.

Procedure

1. Execute [Multi Sensor Adjustment] to correct the sensor for reading crop marks.
2. Tap [Media Settings]>[Cutting Settings]>[Crop Cut Position Adjustment], and then select [High] for [Crop Mark Detection Sensitivity].
If the crop marks still cannot be read, change the media you are using.

RELATED LINKS

- [P. 193 Correcting the Reading Sensor](#)

Are you using transparent media?

The machine cannot read crop marks from transparent media. Change the media you are using.

Printing and Cutting Are Misaligned

Have you corrected the misalignment of printing and cutting with crop marks?

Depending on the composition of the media, the positioning of printing and cutting may be misaligned even when you are using crop marks. Make corrections for misaligned printing and cutting for the media you are using.

RELATED LINKS

- [P. 186 Correcting the Misalignment of Printing and Cutting with Crop Marks \(Concurrent Test for Printing and Cutting with Crop Marks\)](#)
- [P. 189 Correcting the Misalignment of Printing and Cutting with Crop Marks \(Separate Test for Printing/Cutting with Crop Marks\)](#)

Media Feed Problems

Media Wrinkles	286
Is the media loaded and set up straight and securely?	286
Was loaded media allowed to stand for some time?	286
Are the media clamps installed?	286
Was the media loaded while the print heater was hot?	286
Are the media heating system temperatures too high?	286
Is the temperature of the room too low?	286
Is the humidity of the room too high?	286
Is the media sagging?	287
Media Feeding Is Not Straight	288
Is the media loaded and set up straight and securely?	288
Media Feeding Is Not Smooth	289
Is some other object coming into contact with the media?	289
Is the media too thick?	289
Are the grit rollers dirty?	289
A Media Jam Occurs!	290
Is an error message displayed?	290
Is the media warped or wrinkled?	290
Is the height of the print heads too low?	290
Are the grit rollers dirty?	290
Are the media clamps installed?	290
Is the media loaded and set up straight and securely?	290
Is some other object coming into contact with the media?	291
Is the media too thick?	291

Media Wrinkles

Is the media loaded and set up straight and securely?

Feeding is not smooth when the media is not straight or is tensioned unevenly on the left and right. Reload the media.

RELATED LINKS

- [P. 30 Setup of New Media](#)
- [P. 67 Setup of Registered Media](#)

Was loaded media allowed to stand for some time?

Media may wrinkle if it is heated for an extended time. When printing ends, switch off the sub power and remove the media.

Are the media clamps installed?

When you are performing printing, be sure to install the media clamps.

Was the media loaded while the print heater was hot?

Loading media after the print heater has warmed up causes the temperature of the media to rise suddenly, which may cause the media to wrinkle during printing. Before loading media, switch off the sub power and allow the platen to cool.

RELATED LINKS

- [P. 162 Adjusting the Ink-drying Method](#)

Are the media heating system temperatures too high?

Set the temperatures to suitable values for the type of media.

RELATED LINKS

- [P. 162 Adjusting the Ink-drying Method](#)

Is the temperature of the room too low?

The media heating system may not warm up sufficiently when the ambient temperature is less than 20°C (68°F). Also, even when the media heating system reaches its set temperatures, adequate effectiveness may not be apparent if the media is thoroughly chilled. Before printing, allow the media to come to room temperature.

Is the humidity of the room too high?

Use the machine in an environment with a humidity of 35 to 80%RH (no condensation). High humidity can cause the media to sag. If sagging media is used, it may come out wrinkled.

Is the media sagging?

If sagging media is used, it may come out wrinkled.

Media Feeding Is Not Straight

Is the media loaded and set up straight and securely?

Feeding is not smooth when the media is not straight or is tensioned unevenly on the left and right. Reload the media.

RELATED LINKS

- [P. 30 Setup of New Media](#)
- [P. 67 Setup of Registered Media](#)

Media Feeding Is Not Smooth

Is some other object coming into contact with the media?

Make sure the media does not touch anything else. This may affect output, even when the feed appears to be smooth.

RELATED LINKS

- [P. 30 Setup of New Media](#)
- [P. 67 Setup of Registered Media](#)

Is the media too thick?

Media that is too thick may not only cause an unstable feed but may scrape the print heads, resulting in a malfunction. Never use such media.

Are the grit rollers dirty?

Check to make sure the grit rollers are free of buildup of foreign material such as media scraps.

RELATED LINKS

- [P. 228 Cleaning the Machine](#)

A Media Jam Occurs!

Is an error message displayed?

If an error message is displayed because the media has jammed, immediately correct the problem. Doing so may damage the print heads.

RELATED LINKS

- [P. 309 \[Motor Error\]](#)

Is the media warped or wrinkled?

Many factors can cause warping or wrinkling. Refer to the following and correct the problem.

RELATED LINKS

- [P. 286 Media Wrinkles](#)

Is the height of the print heads too low?

Try raising the print heads higher. First, try setting the height to [**Medium**]. If the media is still jammed, change the height to [**High**]. Media may inevitably warp or wrinkle slightly, so adjust the height of the print heads to take this into account.

RELATED LINKS

- [P. 153 Changing the Print Head Height](#)

Are the grit rollers dirty?

Check to make sure the grit rollers are free of buildup of foreign material such as media scraps.

RELATED LINKS

- [P. 228 Cleaning the Machine](#)

Are the media clamps installed?

When you are performing printing, be sure to install the media clamps.

Is the media loaded and set up straight and securely?

Feeding is not smooth when the media is not straight or is tensioned unevenly on the left and right. Reload the media.

RELATED LINKS

- [P. 30 Setup of New Media](#)
- [P. 67 Setup of Registered Media](#)

Is some other object coming into contact with the media?

Make sure the media does not touch anything else. This may affect output, even when the feed appears to be smooth.

RELATED LINKS

- [P. 30 Setup of New Media](#)
- [P. 67 Setup of Registered Media](#)

Is the media too thick?

Media that is too thick may not only cause an unstable feed but may scrape the print heads, resulting in a malfunction. Never use such media.

Machine Problems

The Print Heads Do Not Move	293
What to Do First	293
If the Print Heads Still Do Not Move	293
The printer unit does not run.....	295
Is the power switched on?	295
Is [Output possible.] displayed?	295
Are any covers open?	295
Is the message [Output is currently paused.] displayed on the screen?	295
Is a message displayed on the screen?	295
Are the cables connected?	295
Is the LAN routing appropriate?	296
Are the LAN settings correct?	296
Did the software RIP end abnormally?	296
Is an [Ink Pouch Tray Error] displayed?	296
The Media Heating System Doesn't Warm Up.....	298
Is the media loaded?	298
Is [Heater Power] turned on?	298
Is the temperature of the room too low?	298
Cannot Separate the Media	299
Is the separating knife installed?	299

The Print Heads Do Not Move

If the print-head carriage stops over the platen, take action immediately to prevent the heads from drying out.

What to Do First

Switch the sub power off and then back on again. If the media is jammed, also remove the media.

If the print heads move to the home position (inside the right cover), it means the operation has ended successfully.

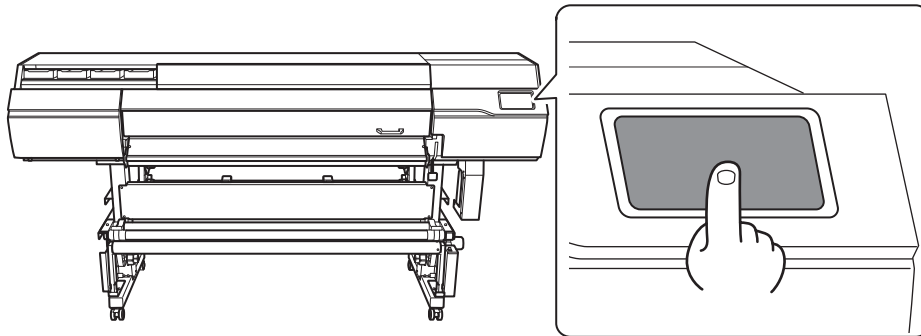

If the Print Heads Still Do Not Move

Try switching off the sub power, followed by the main power, then switching on the main power again, followed by the sub power.

If the Print Heads Still Do Not Move

If the heads still do not move, carry out the following emergency response measure, and then contact your authorized Roland DG Corporation dealer.

Procedure

1. Switch off the sub power.
2. Switch off the main power, and then open the front cover.
3. Open the right cover.

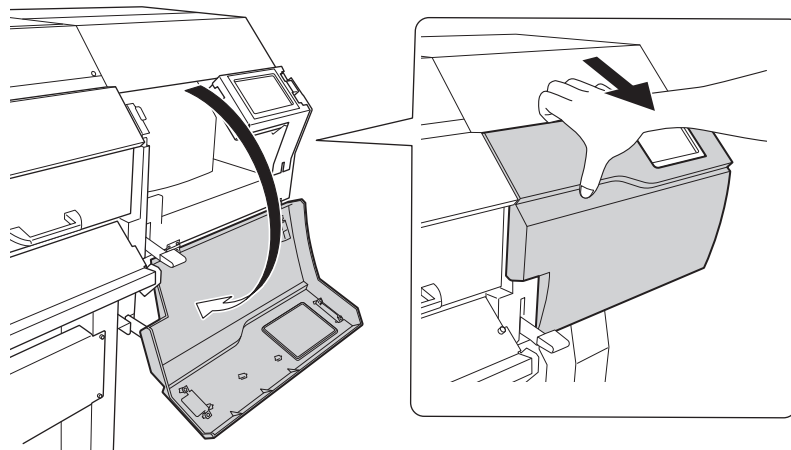

- 4. Gently move the print-head carriage to the home position by hand.**
Stopping at the place where the audible click is heard locks the print-head carriage in place.

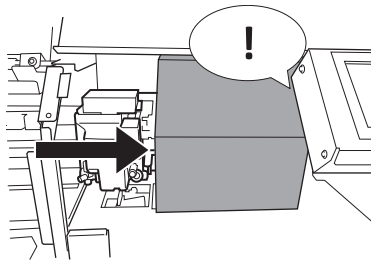

- 5. Gently apply pressure from the right side to make sure the print-head carriage does not move to the left.**
If the print-head carriage moves to the left, move it again slowly by applying pressure from the left side and make sure it locks in place.

The printer unit does not run



Is the power switched on?

Switch on the printer's main power, followed by the sub power and make sure the home screen appears.

RELATED LINKS

- [P. 25 Turning the Power On](#)

Is [Output possible.] displayed?

Output is not performed when [Output possible.] is not displayed at the top of the operation panel. After loading the media and lowering the loading lever, tap  [Setup]. Follow the instructions on the screen to finish setting up the media. Also, when operating the setting menu, output doesn't start when data is sent from the computer with some menu items. When you return to a menu item where output is possible or tap  to return to the home screen, output starts.

RELATED LINKS

- [P. 119 Starting Output](#)

Are any covers open?

Close the front, left, and right covers.

Is the message [Output is currently paused.] displayed on the screen?

When [Output is currently paused.] is displayed on the screen, operation is paused. To resume, tap [Resume].

RELATED LINKS

- [P. 102 Pausing and Canceling Output](#)

Is a message displayed on the screen?

RELATED LINKS

- [P. 301 Messages](#)
- [P. 306 Error Messages](#)

Are the cables connected?

Connect the cables securely.

RELATED LINKS

The printer unit does not run

- [SG3-540/300 Setup Guide \(https://downloadcenter.rolanddg.com/ "Setup Guide\)](https://downloadcenter.rolanddg.com/)

Is the LAN routing appropriate?

Check whether or not the network routing is appropriate. Try connecting the computer and the machine to the same hub or connecting them directly using a cable. If this makes it possible to perform output, it means the problem may be in the network itself.

Are the LAN settings correct?

If the cable connections are secure and no problem is found in the network itself, make sure that the IP address and other such settings are appropriate. The settings on both the machine and the computer must be appropriate. Redo the settings, checking to ensure that the IP address does not conflict with the IP address for another device on the network, that the port setting for the software RIP specifies the IP address set on the machine, that the settings have no typing errors, and for other such problems.

RELATED LINKS

- [P. 215 Viewing Printer Information](#)
- [SG3-540/300 Setup Guide \(https://downloadcenter.rolanddg.com/ "Setup Guide\)](https://downloadcenter.rolanddg.com/)

Did the software RIP end abnormally?

Make sure the software RIP is running correctly, then switch the sub power switch off and back on.

RELATED LINKS

- [VersaWorks manual \(https://downloadcenter.rolanddg.com/VersaWorks6\)](https://downloadcenter.rolanddg.com/VersaWorks6)

Is an [Ink Pouch Tray Error] displayed?

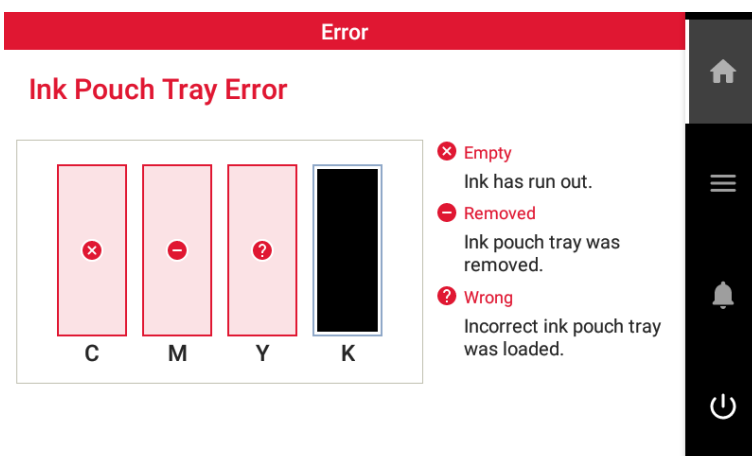

When an [Ink Pouch Tray Error] appears on the display screen, output data cannot be accepted. If there is data that has not yet been output remaining in the machine, output resumes when the error is cleared. If there is unsent data in the computer, output resumes when the data is resent.

When ink runs out

Replace the ink pouch with a new one.

When an ink pouch tray with the incorrect color is loaded

Remove the ink pouch tray that was loaded incorrectly and load the appropriate ink pouch tray.

When an ink pouch tray is removed or has not been securely loaded

Securely load the ink pouch tray by pushing it all the way to the back.

RELATED LINKS

- [P. 109 Ink Pouch Replacement](#)
- [P. 306 \[Ink Pouch Tray Error\]](#)

The Media Heating System Doesn't Warm Up

Is the media loaded?

By default, simply switching on the power does not make the media heating system warm up to the preset temperature. Load the media and wait for the machine to warm up.

RELATED LINKS

- [P. 162 Adjusting the Ink-drying Method](#)

Is [Heater Power] turned on?

If [Cut Only] is selected for [Select Media Output Type] in the media setup, [Heater Power] is set to [Off] and the media heating system does not heat up. Perform setup again with the [Print Only/Print & Cut] output type or set [Heater Power] to [On].

RELATED LINKS

- [P. 30 Setup of New Media](#)
- [P. 67 Setup of Registered Media](#)
- [P. 171 Switching Off the Print Heater and Dryer Together](#)

Is the temperature of the room too low?

The media heating system may not warm up sufficiently when the ambient temperature is less than 20°C (68°F). Also, even when the media heating system reaches its set temperatures, adequate effectiveness may not be apparent if the media is thoroughly chilled. Before printing, allow the media to come to room temperature.

Cannot Separate the Media

Is the separating knife installed?

If the separating knife is not installed, you cannot separate the media.

RELATED LINKS

- [P. 269 Replacing the Separating Knife](#)

Messages on the Operation Panel

Messages	301
[When output, cleaning, and other operations are completed, discard the discharged fluid.]	301
[The time for manual cleaning has arrived.]	301
[The time for wiper replacement has arrived.]	301
[The time for wiper tray cleaning has arrived.]	301
[Print head protection mode has activated.]	301
[Remaining cleaning liquid level low.]	302
[Replace the cleaning liquid pouch.]	302
[Install the cleaning liquid pouch.]	302
[The time for ink mixing has arrived.]	302
[Operation of the take-up unit stopped.]	303
[Place the middle pinch rollers over all the grit rollers.]	303
[Install the media clamps correctly.]	303
[Media clamps could not be detected.]	303
[The LAN cable is not connected.]	304
[Connection is requiring too much time. Manually setting the IP address will improve the connection speed.]	304
[The media could not be detected automatically. Manually set the printing area.]	304
Error Messages	306
[Ink Pouch Tray Error]	306
[Cover Open Error]	306
[Media End Error]	306
[Pinch Lever Error]	307
[Media Loading Error]	307
[Drain Bottle Error]	307
[Crop Mark Detection Error]	307
[Unable to Fill Wiper Cleaning Liquid]	308
[Pinch Roller Error]	308
[Print Head Height Mismatch]	308
[Insufficient Media Width]	308
[Motor Error]	309
[Print Head Dry-out Error]	309
[Low Temperature Error]	309
[High Temperature Error]	310
[Pump Stop Error]	310
[Cleaning Error (Ink Pouch Tray)]	310
[Cleaning Error (Drain Bottle)]	310
[Take-up Unit Communication Error]	310
[Service Call]	310
[Software error]	311

Messages

These are the main messages that appear on the machine's display to prompt correct operation. These messages are not errors, so you can close them and perform other work. To check messages again or to carry out their corresponding actions, tap  to display the list of messages. Tap a message to display the menus and procedure required for the action. Perform operations according to the on-screen instructions.

[When output, cleaning, and other operations are completed, discard the discharged fluid.]

This message appears when a certain amount of discharged fluid collects in the drain bottle. Tap [When output, cleaning, and other operations are completed, discard the discharged fluid.]>[Execute] to discard this fluid.

RELATED LINKS

- [P. 240 If the Discharged Fluid Disposal Message Appears](#)

[The time for manual cleaning has arrived.]

This message appears when it is time to perform manual cleaning. Tap [The time for manual cleaning has arrived.]>[Execute] to perform manual cleaning.

RELATED LINKS

- [P. 231 Manual Cleaning Method](#)

[The time for wiper replacement has arrived.]

This message appears when it is time to replace the wiper. Tap [The time for wiper replacement has arrived.]>[Execute] to replace the wiper.

RELATED LINKS

- [P. 256 Replacing the Wiper and the Tray Pad](#)

[The time for wiper tray cleaning has arrived.]

This message appears when it is time to clean the wiper tray. Tap [The time for wiper tray cleaning has arrived.]>[Execute] to clean the wiper tray.

RELATED LINKS

- [P. 259 Cleaning the Wiper Tray](#)

[Print head protection mode has activated.]

This message appears when the ink in use may not be a product specified by Roland DG Corporation.

If the ink is not a product specified by Roland DG Corporation, a larger amount of ink will be consumed, and drying will be performed frequently. To obtain optimal performance, we recommend that you use ink specified by Roland DG Corporation. To purchase ink, contact your authorized Roland DG Corporation dealer.

[Remaining cleaning liquid level low.]

This message appears when there is a small amount of cleaning liquid remaining.

Prepare new cleaning liquid to replace the existing liquid when it runs out.

[Replace the cleaning liquid pouch.]

This message appears when a pouch tray with no cleaning liquid pouch is loaded or when there is no wiper cleaning liquid.

Quickly and correctly insert a new cleaning liquid pouch into the pouch tray and load it in the printer or replace the empty cleaning liquid pouch.

When you load new cleaning liquid, a confirmation screen appears. Tap **[Yes]** to reset the amount of cleaning liquid remaining and identify the cleaning liquid pouch as a new product.

RELATED LINKS

- [P. 113 Cleaning Liquid Pouch Replacement](#)

[Install the cleaning liquid pouch.]

This message appears when the pouch tray is removed from the machine.

Quickly insert a cleaning liquid pouch.

After you insert the pouch tray, the cleaning liquid pouch replacement confirmation screen appears.

- If you have replaced the cleaning liquid pouch, tap **[Yes]**. The amount of cleaning liquid remaining is reset.
- If you have not replaced the cleaning liquid pouch, tap **[No]**. The amount of cleaning liquid remaining is not changed.

MEMO

If you tap **[Yes]** on the cleaning liquid pouch replacement confirmation screen even though you have not replaced the cleaning liquid pouch, the amount of cleaning liquid remaining is reset. In this situation, no notification will appear even if the amount of cleaning liquid remaining is very small, and the message **[Replace the cleaning liquid pouch.]** will appear when the cleaning liquid runs out. To ensure you have enough time to prepare the replacement cleaning liquid, tap **[No]** if you have not replaced the cleaning liquid.

RELATED LINKS

- [P. 113 Cleaning Liquid Pouch Replacement](#)

[The time for ink mixing has arrived.]

This message appears when it is time to mix the ink.

When **[Ink Mixing Notification]** accessed with **[Preferences]>[Notifications On/Off]** is on, this message appears when 1 week elapses from the last time the ink was mixed.

Tap **[The time for ink mixing has arrived.]** to display the confirmation screen.

Remove a pouch tray, shake it 50 times (for approximately 20 seconds), and then reinsert it. Perform this operation for all the pouch trays. On completion, tap [Yes].

[Operation of the take-up unit stopped.]

This message appears and the take-up unit stops when it is not possible to detect the position of the dancer roller for a continuous length of time during media feeding or pull back.

Tap [Operation of the take-up unit stopped.] and follow the instructions on the screen to recover the take-up unit.

[Place the middle pinch rollers over all the grit rollers.]

This message appears when the middle pinch rollers have not been properly placed.

Position these pinch rollers properly between the left and right pinch rollers.

RELATED LINKS

- [P. 30 Setup of New Media](#)
- [P. 67 Setup of Registered Media](#)

[Install the media clamps correctly.]

This message appears when the media clamps are not placed at the predetermined positions.

Check the loading status of the media and that the pinch rollers have been positioned correctly, and then correctly set the media clamps at the ends of the media.

RELATED LINKS

- [P. 30 Setup of New Media](#)
- [P. 67 Setup of Registered Media](#)

[Media clamps could not be detected.]

This message appears when the media clamps cannot be detected because they are hidden by the media.

Check the loading status of the media and that the pinch rollers have been positioned correctly, and then correctly set the media clamps at the ends of the media.

This message appears when the media clamps cannot be detected because their parts that are read are dirty with, for example, ink.

Use cleaning liquid and a cleaning stick to clean the white parts on the media clamps.

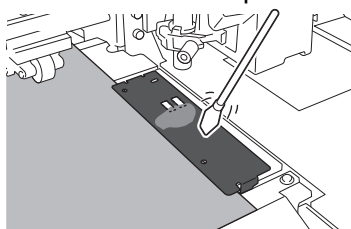

It may not be possible to detect the media clamps because the multi sensor is dirty with ink due to reasons such as the media striking it immediately after printing.

Install the media clamps correctly and clean their parts that are read. If this message still appears, contact your authorized Roland DG Corporation dealer.

RELATED LINKS

- [P. 30 Setup of New Media](#)
- [P. 67 Setup of Registered Media](#)

[The LAN cable is not connected.]

This message appears when the machine and a computer are not connected with a LAN cable. Properly connect the LAN cable.

[Connection is requiring too much time. Manually setting the IP address will improve the connection speed.]

This message appears when automatic IP address acquisition is enabled and the machine connects to a network on which no DHCP server exists while this automatic acquisition is in progress.

Connect to a network on which a DHCP server exists or disable automatic IP address acquisition and set a fixed IP address.

[The media could not be detected automatically. Manually set the printing area.]

This message appears when media with high reflectance is set up. Manually set the printing area.

Procedure

1. Tap [OK] on the screen displaying the above message.
2. Tap [Change].
The [Set the right edge of the printing area within the area specified by the pinch rollers.] screen appears.
3. Hold down  to move the center of the blade (A) approximately 2 mm (0.08 in.) to the inside (B) from the left edge of the right pinch roller.

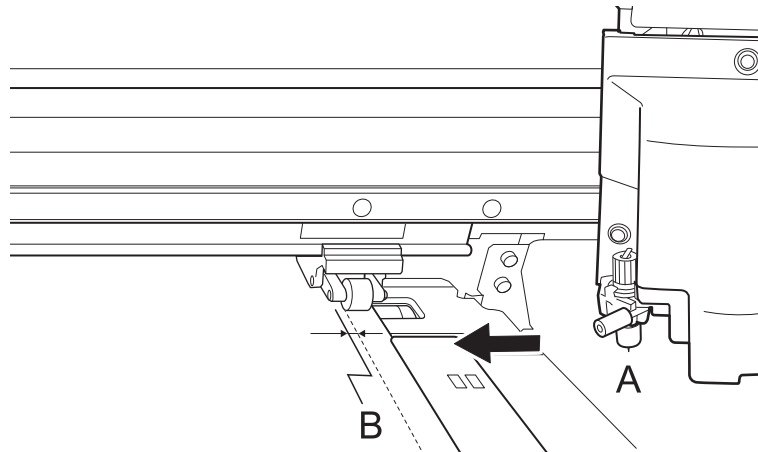

4. Tap [OK].

The [Set the left edge of the printing area within the area specified by the pinch rollers.] screen appears.

5. Hold down  to move the center of the blade (A) approximately 2 mm (0.08 in.) to the inside (B) from the right edge of the left pinch roller.

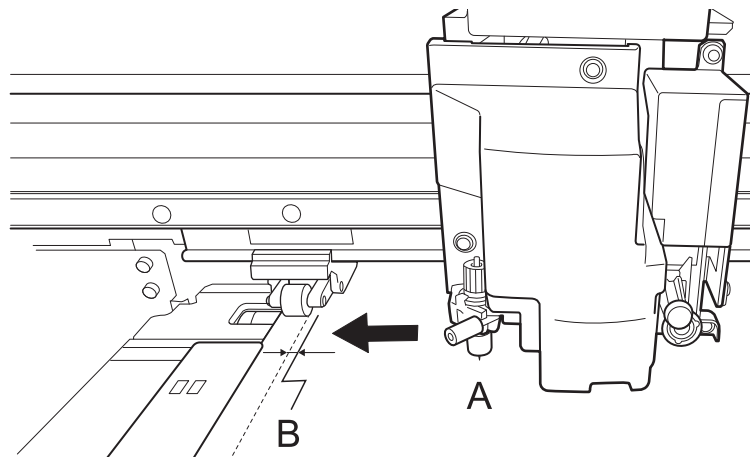

6. Tap [OK].

The set left and right positions are applied to the [Printing Area (Width)].

7. Tap [OK].

Error Messages

This section describes the error messages that may appear on the machine's display and how to take action to remedy the problem.

If an error message appears, all screen operations other than switching the power off are disabled. Follow the instructions on the screen to clear the error or switch the power off before starting to operate the machine again.

If the action displayed on the screen does not correct the problem or if an error message not described here appears, contact your authorized Roland DG Corporation dealer.

[Ink Pouch Tray Error]

This message appears when one of the following ink pouch tray errors is detected.

MEMO

When an error occurs, the , , or  icon is displayed next to the corresponding ink pouch tray on the screen.

Implement appropriate countermeasures according to the error.

- **When ink runs out**

 **[Empty]** [Ink has run out.]

Replace the ink pouch with a new one, and then load the ink pouch tray.

- **When an ink pouch tray is removed**

 **[Removed]** [Ink pouch tray was removed.]

Load the ink pouch tray that was removed.

- **When an ink pouch tray with the incorrect color is loaded**

 **[Wrong]** [Incorrect ink pouch tray was loaded.]

Remove the ink pouch tray that was loaded incorrectly and load the correct ink pouch tray.

When an incorrectly loaded ink pouch tray is removed,  **[Removed]** [Ink pouch tray was removed.] is displayed.

[Cover Open Error]

The front, right, or left cover is open.

For safety, the machine stops if a cover is opened during operation.

Close the open cover.

[Media End Error]

This message appears when one of the following situations is detected.

- Insufficient remaining media during take-up unit setup or printing output
- No media during media feeding

Switch to new media, and then send the data again.

[Pinch Lever Error]

The loading lever was raised during media setup or after completing this setup.
Lower the loading lever and redo setup.

[Media Loading Error]

This message appears when [Media Edge Detection] is set to [Enable] and media has not been fed with the pinch rollers set incorrectly.

Raise the loading lever, set the pinch rollers correctly, and then set up the media again.

This message appears when [Media Edge Detection] is set to [Enable] and the media is too short.

The media is not long enough to be detected. Raise the loading lever, set [Media Edge Detection] to [Disable], and then reload the media.

For the setup method when [Media Edge Detection] is set to [Disable], refer to [1. B: Determine the positions of the media \(\[Media Edge Detection\]: \[Disable\]\).\(P. 58\)](#).

RELATED LINKS

- [P. 30 Setup of New Media](#)
- [P. 67 Setup of Registered Media](#)

[Drain Bottle Error]

This message appears when the drain bottle has reached its limit for discharged fluid.

Discard the discharged fluid in the drain bottle, and then attach this bottle again.

MEMO

When the drain bottle is detached, the error message changes to [Install the drain bottle.].

This message appears when the drain bottle is misaligned.

Install the drain bottle again.

[Crop Mark Detection Error]

[Crop marks could not be detected.]

Automatic detection of crop marks could not be accomplished.

Try to make corrections using [Multi Sensor Adjustment] (the correction function of the sensor for reading crop marks). Depending on the media, it may not be possible to detect crop marks automatically.

[Crop marks were detected however the size or position was incorrect.]

Automatic detection of crop marks could not be accomplished.

Load the media at the correct position and perform detection of crop marks again. If repeating automatic crop-mark detection also results in an error, start over again from the printing of crop marks.

RELATED LINKS

- [P. 30 Setup of New Media](#)
- [P. 67 Setup of Registered Media](#)

- [P. 134 How to Cut with Crop Marks](#)
- [P. 193 Correcting the Reading Sensor](#)

[Unable to Fill Wiper Cleaning Liquid]

The cleaning liquid pouch ran out while supplying this liquid for cleaning or to the wiper tray. Quickly replace this cleaning liquid pouch with a new one.

[Pinch Roller Error]

The left (right) pinch roller is positioned at a location where it cannot pinch the media. Raise the loading lever and move the pinch roller to the correct location.

RELATED LINKS

- [P. 30 Setup of New Media](#)
- [P. 67 Setup of Registered Media](#)

[Print Head Height Mismatch]

The set print head height and the actual print head height are different.

Follow the instructions on the screen to change the print head height. When you change this height, [OK] is displayed on the screen. Tap [OK] to resume printing.

If 10 minutes elapse after the print head carriage moves, this carriage is capped and the data is canceled to prevent the heads from drying out.

RELATED LINKS

- [P. 153 Changing the Print Head Height](#)

[Insufficient Media Width]

[The print data is larger than the media width. Continue output?]

This message appears when the size of the printing data is larger than the printing area of the loaded media.

To continue performing output without making corrections, tap [Continue Output]. At this time, the portion extending beyond the printing area is not output.

To cancel output, tap [Cancel]. Make the printing area wider, for example, by replacing the media with a larger piece of media, and then send the data again.

MEMO

There is no limitation on the size of the data in the media-feed (FEED) direction.

[Crop marks cannot be added because the print data is larger than the media width. Continue output?]

This message appears when one of the following situations is detected.

- The size of the data with crop marks is larger than the printing area of the loaded media.
- The width of the printing data is 60 mm (2.36 in.) or less.

To continue performing output without making corrections, tap [**Continue Output**]. The data is output without printing the crop marks.

To cancel output, tap [**Cancel**]. Make the printing area wider, for example, by replacing the media with a larger piece of media, and then send the data again.

The size of the data being output is too small.

Make the horizontal-direction (scan-direction) size of the data at least 60 mm (2.6 in.). To continue performing output without making corrections, tap [**Continue Output**]. At this time, the data is output without printing the crop marks.

To stop output, stop sending data from the computer, and then raise the loading lever. Increase the size of the data, and then send the data again.

MEMO

There is no limitation on the size of the data in the media-feed (FEED) direction.

[Motor Error]

A motor error occurred.

Operation cannot be continued. Turn off the sub power. Next, eliminate the cause of the error, then immediately switch on the sub power.

If the machine is allowed to stand with the error uncorrected, the print heads may dry out and become damaged. This error may be caused by such factors as a mistake in loading the media, a media jam, or an operation that pulls the media with excessive force.

The media has jammed.

Carefully remove the jammed media. The print heads may also be damaged. Perform head cleaning, and then perform a printing test and check the results.

Has the media been pulled with excessive force?

Excessive tension was applied to the media, and additional action is necessary to recover from this state. First, raise the loading lever and adjust the media to create a small amount of slack, and then switch on the sub power.

[Print Head Dry-out Error]

This message appears when the print heads are forced to the home position to prevent them from drying out.

Operation cannot be continued. Switch the sub power off, and then back on.

[Low Temperature Error]

The temperature of the location where the machine is installed has fallen below the ambient temperature at which the machine can operate.

This message appears when the temperature falls to 5°C (41°F) or lower during startup or to 2°C (35.6°F) or lower during operation.

Operation cannot be continued. Turn off the sub power.

The displayed temperature is the current ambient temperature of the installation location. Bring the installed location to a temperature at which operation is possible (20°C to 32°C [68°F to 89.6°F]), allow the machine to come to room temperature, and then turn on the power.

RELATED LINKS

- [P. 25 Power Supply Operations](#)

[High Temperature Error]

The temperature of the location where the machine is installed has risen above the ambient temperature at which the machine can operate.

This message appears when the temperature rises to 42 °C (107.6 °F) or higher during startup or operation (when recovering from sleep mode).

Operation cannot be continued. Turn off the sub power.

The displayed temperature is the current ambient temperature of the installation location. Bring the installed location to a temperature at which operation is possible (20 °C to 32 °C [68 °F to 89.6 °F]), allow the machine to come to room temperature, and then turn on the power.

RELATED LINKS

- [P. 25 Power Supply Operations](#)

[Pump Stop Error]

This message appears when an ink pouch tray is pulled out during pump operation, such as during cleaning, and is left in this state for 10 minutes or more.

Operation cannot be continued. Switch the sub power off, and then back on.

[Cleaning Error (Ink Pouch Tray)]

A pouch tray was pulled out during the first ink filling procedure for the machine, causing it to make an emergency stop.

Operation cannot be continued. Before turning the sub power off and then back on, check that the ink pouch trays are inserted.

[Cleaning Error (Drain Bottle)]

This message appears when the drain bottle is removed during the first ink filling procedure for the machine.

Operation cannot be continued. Switch the sub power off, and then back on.

[Take-up Unit Communication Error]

This message appears when an error such as the connection being lost during take-up unit setup occurs.

Operation cannot be continued. Switch off the sub power, followed by the main power. Check that the take-up unit is properly connected, and then once more switch on the main power, followed by the sub power.

[Service Call]

An unrecoverable error occurred or part replacement that must be performed by a service technician is required.

After turning the power off, contact your authorized dealer.

[Software error]

An error occurred in the internal communication or applications of the machine or part replacement that must be performed by a service technician is required.

Switch off the main power. Then, switch on the main power again, followed by the sub power. If the error still occurs, contact your authorized Roland DG Corporation dealer.

Appendix

Operations When Moving the Unit

Preparing to Move the Machine.....	314
Step 1: Removing Media and the Blade Holder	314
Step 2: Discharging the Wiper Tray Cleaning Liquid	316
Step 3: Secure the print heads in place using the retainer.	317
Step 4: Reinstalling the Machine	318

Preparing to Move the Machine

Before moving the machine, dispose of the discharged fluid and secure the print heads in place. Attempting to move the machine without first performing these preparations may result in damage to internal components due to leaking ink or damage to the print heads.

IMPORTANT

- Once the preparations for moving the machine are complete, move the machine promptly and turn on the machine as soon as possible after the machine is relocated. If you leave the machine alone without turning it on, the precipitated ink will coagulate and result in problems such as the clogging of the print heads.
- When moving the machine, keep it at a temperature between 5 and 40°C (41 and 104°F) and at a relative humidity between 20 and 80% (no condensation). Failure to do so may result in a breakdown.
- Handle the machine with care when moving it, keeping it level (not tilted at an angle) and preventing it from striking other objects.

Step 1: Removing Media and the Blade Holder

MEMO

The procedure for replacing the blade is displayed on the operation panel, but this section only describes the work for removing the blade.

Procedure

1. Remove any media.

If any media has been loaded, remove it.

If no media is loaded, raise the loading lever.

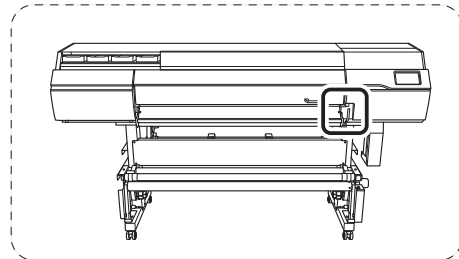
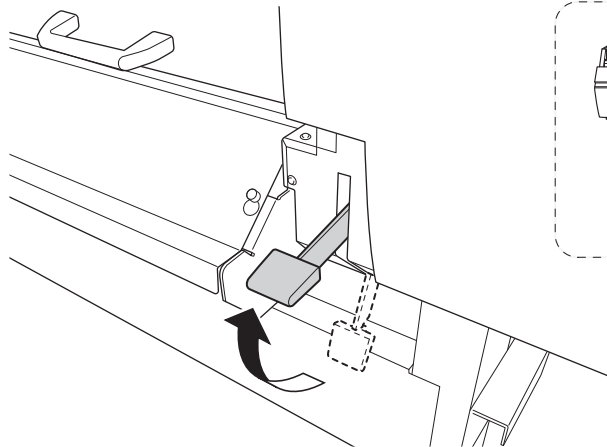

2. Tap .

3. Tap [Maintenance]>[Blade Replacement].

The [Blade Replacement] screen appears.

4. Tap [Execute].

The cutting carriage moves to a position where blade replacement is possible.

5. When [Open the front cover.] appears, open the front cover.
6. Detach the blade holder.
7. Tighten the screw.
8. Tap [Finish All].
9. Close the front cover.
10. Tap  to go back to the original screen.

Step 2: Discharging the Wiper Tray Cleaning Liquid

Procedure

1. Tap .
2. Tap [Maintenance]>[Wiper Tray Discharging].
The [Wiper Tray Discharging] screen appears.
3. Tap [Execute].
Discharging of wiper tray cleaning liquid starts. On completion, the sub power switches off.
4. Remove the drain bottle and discard the discharged fluid.

IMPORTANT

When you remove the drain bottle, a few drops of discharged fluid may come out of the machine. Exercise caution to prevent this fluid from soiling your hands or the floor.

⚠ WARNING

Never place discharged fluid or ink near an open flame.
Doing so may cause a fire.

⚠ CAUTION

To store discharged fluid temporarily, place it in the included drain bottle or in a durable sealed container such as a metal can or polyethylene tank, and cap the container tightly.
Any spillage or vapor leakage may cause fire, odor, or physical distress.

IMPORTANT

Do not store discharged fluid in a location where it is exposed to direct sunlight.
When temporarily storing discharged fluid in the included drain bottle, do not store it in a location that is exposed to direct sunlight. The discharged fluid may harden, making the drain bottle unusable. The drain bottle may also deteriorate, leading to discharged fluid leaks.

IMPORTANT

Dispose of discharged fluid properly, in accordance with the laws in effect in your locale.
Discharged fluid is flammable and contains toxic ingredients. Never attempt to incinerate discharged fluid or discard it with ordinary trash. Also, do not dispose of it in sewer systems, rivers, or streams. Doing so may have an adverse impact on the environment.

5. Quickly attach the emptied bottle to the machine once more.
6. Turn off the main power switch.

Step 3: Secure the print heads in place using the retainer.

Procedure

- 1. Open the left cover.

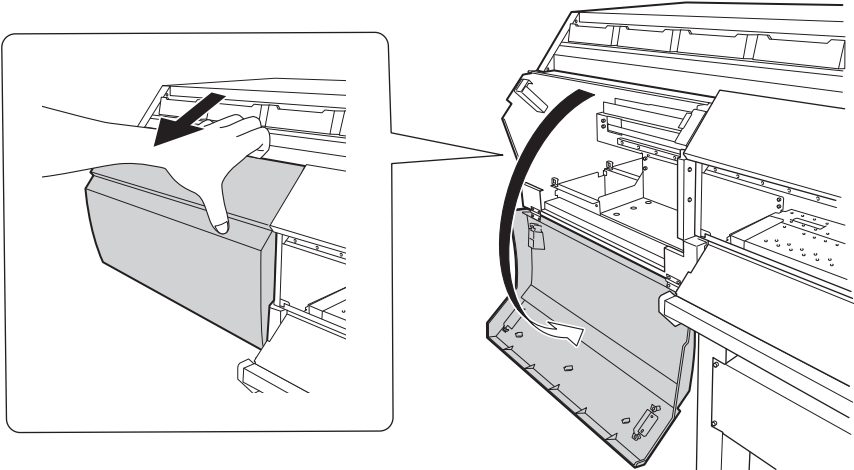

- 2. Remove the retainers.

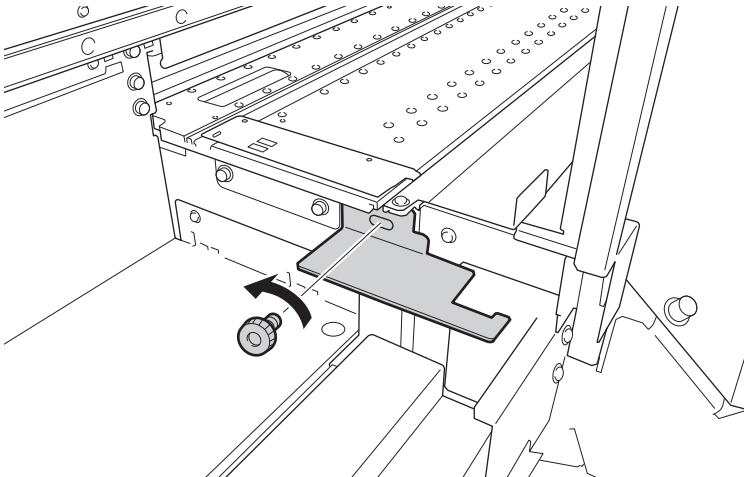

- 3. Catch the retainer on hole A, and then use the screw to secure the retainer in the position shown in the figure.

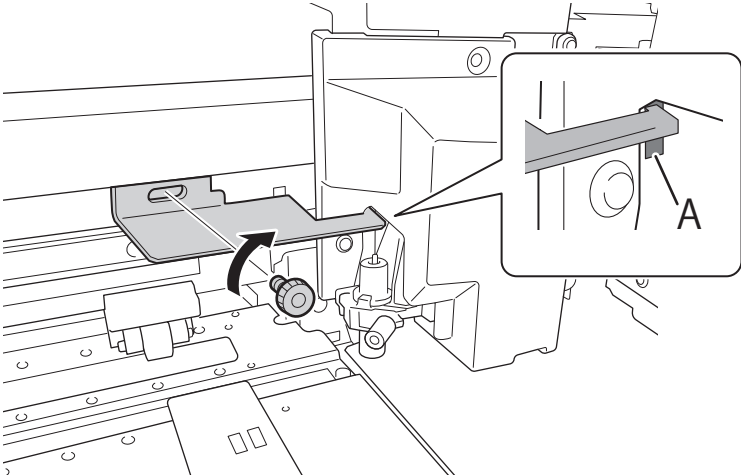

Step 4: Reinstalling the Machine

Procedure

1. Once the preparations are complete, move the machine with as little delay as possible.
2. Reinstall the printer immediately, and then remove the retainer securing the print heads in place.

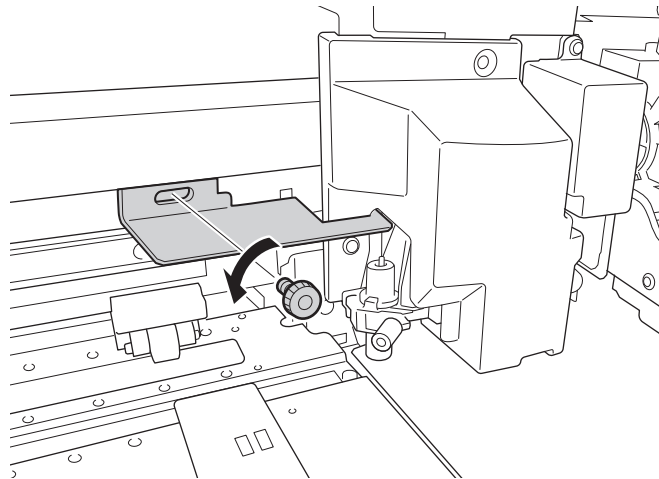

3. Install the retainer at the position indicated in the figure for storage.

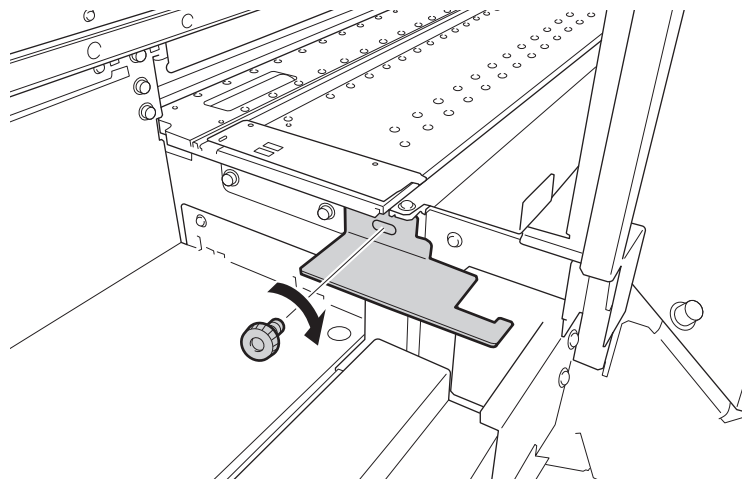

4. Turn on the main power switch.

IMPORTANT

To prevent the print heads from being damaged, move the machine with as little delay as possible and switch on the main power as soon as possible after moving the machine. To install the machine again, follow the procedure in the Setup Guide.

5. Press the sub power button.

The home screen appears, and then the machine is filled with cleaning liquid.

MEMO

If the initial setup or the ink filling is not complete, the language selection screen will appear. Follow the instructions on the screen to carry out the initial setup and ink filling.

RELATED LINKS

- [P. 113 Cleaning Liquid Pouch Replacement](#)

Main Specifications

- Printing/Cutting Area 321
 - Maximum Area 321
 - Maximum Printing Area When Using Crop Marks..... 322
 - Media Separation Location during Continuous Printing..... 323
- About the Blade..... 324

Printing/Cutting Area

Maximum Area

The printing or cutting area along the horizontal plane (the direction in which the carriages move) is determined by the position of the pinch rollers.

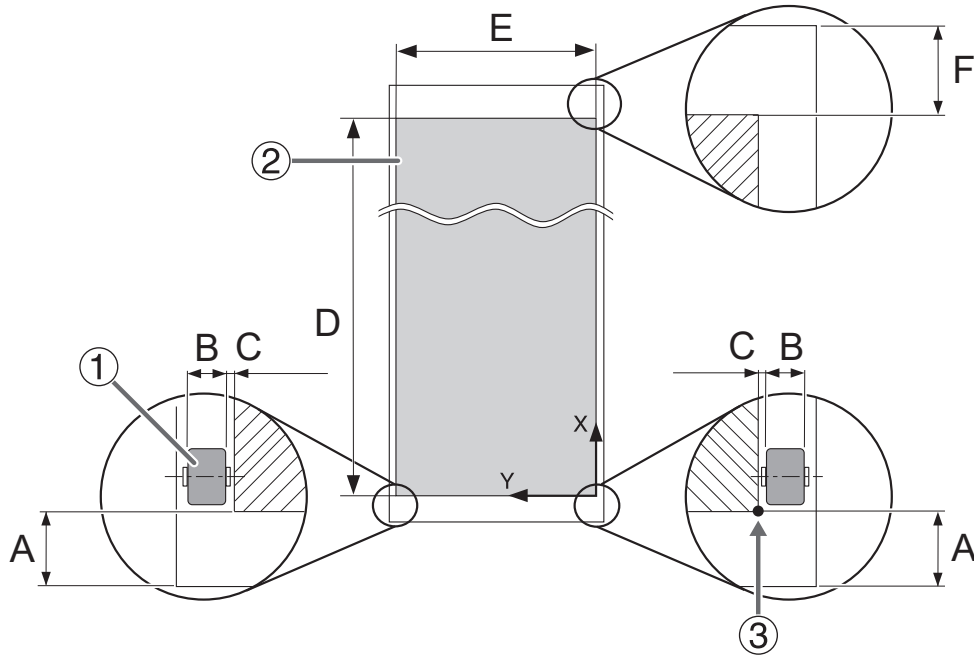

①	Pinch roller
②	Printing or cutting area
③	Printing or cutting coordinates origin (0,0)
A	75 mm (3 in.)
B	10 mm (0.4 in.)
C	1.5 mm (0.06 in.)
D	Max. 24,998 mm (984.2 in.)
E	54-inch model: Max. 1,346 mm (52.9 in.), 30-inch model:Max. 737 mm (29 in.)
F	105 mm (4.13 in.)

Maximum Printing Area When Using Crop Marks

The maximum printing area when crop marks are used is reduced from the maximum printing area when crop marks are not used by an amount equal to the crop marks.

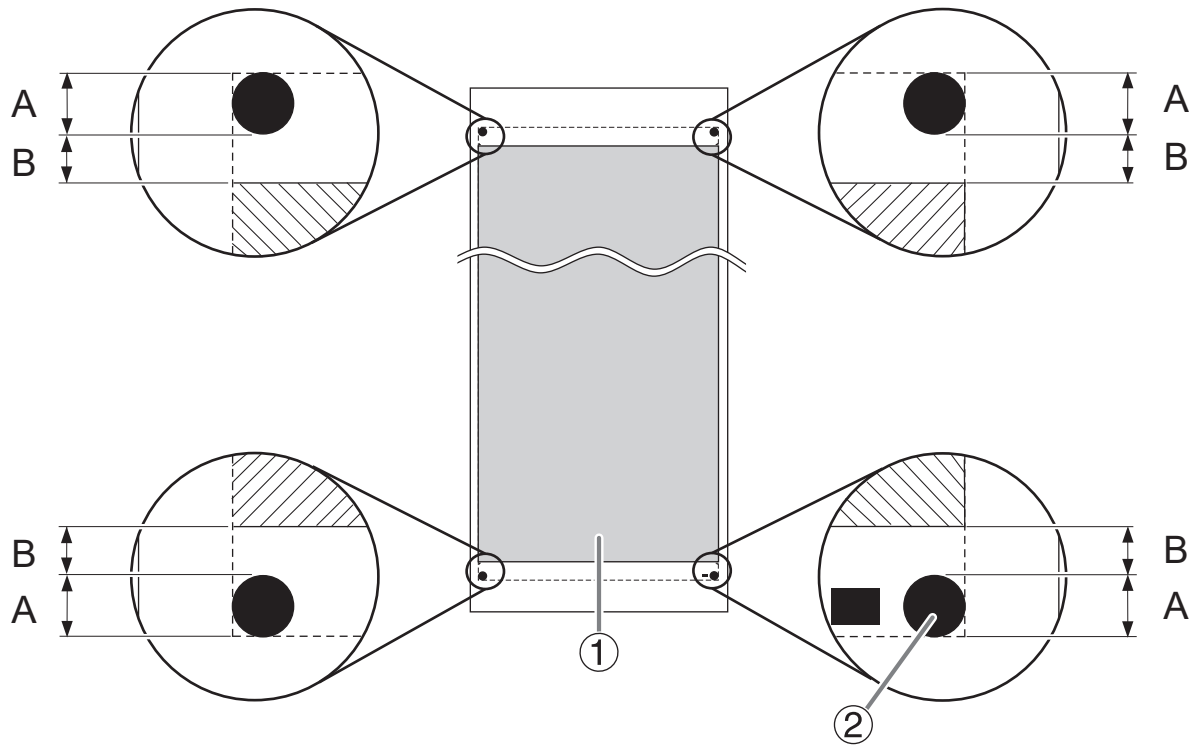

①	Maximum printing area
②	Crop mark
A	12.5 mm (0.5 in.)
B	10 mm (0.4 in.)

Media Separation Location during Continuous Printing

When a command for separating the media is sent from the computer, the separation location on the media is as shown in the figure below.

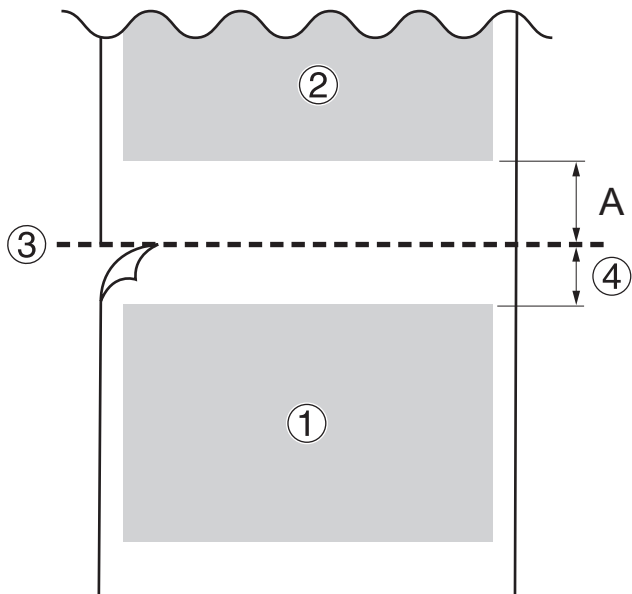

①	First page
②	Second page
③	Separation location
④	Margin (software RIP value)
A	75 mm (3 in.)

About the Blade

The cutting conditions and the service life of the blade change according to the media and the operating environment, even when you're using identical blades. The service life also differs according to the type of blade. A rough guide is shown below.

Blade	Media	Blade force	Amount of blade offset (amount of blade tip correction)	Blade life (general guide) ^{*1}
ZEC-U5032	General Signage Vinyl	30 to 100 gf	0.25 mm (0.01 in.)	8,000 mm (26,246.7 ft.)
ZEC-U5025	General Signage Vinyl	30 to 100 gf	0.25 mm (0.01 in.)	4,000 mm (13,123.4 ft.)
	Fluorescent Vinyl	120 to 200 gf	0.25 mm (0.01 in.)	4,000 mm (13,123.4 ft.)
	Fluorescent Vinyl	100 to 200 gf	0.25 mm (0.01 in.)	4,000 mm (13,123.4 ft.)

*1 The values for "Blade life" are estimates for when an identical type of media is used.

When uncut areas remain even when the blade force is increased to a value that is higher than the values shown in this chart by 50 to 60 gf, replace the blade.

