

# *Versa***STUDIO** **BD-8**

---

## User's Manual

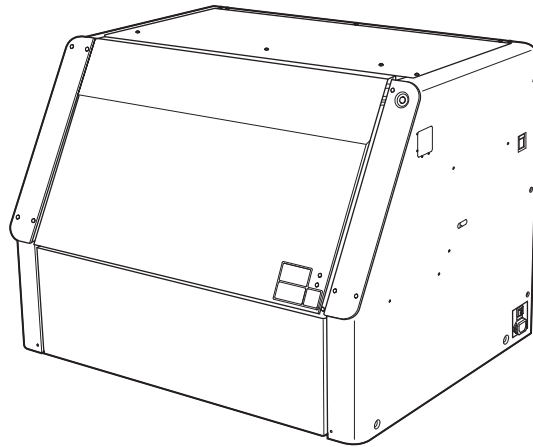

---

Thank you very much for purchasing this product.

- To ensure correct and safe usage with a full understanding of this product's performance, please be sure to read through this manual completely.
- Unauthorized copying or transferal, in whole or in part, of this manual is prohibited.
- The specifications of this product and the contents of this operation manual are subject to change without notice.
- The operation manual and the product have been prepared and tested as much as possible. If you find any misprints or errors, please inform us.
- Roland DG Corporation assumes no responsibility for any direct or indirect loss or damage that may occur through use of this product, regardless of any failure to perform on the part of this product.
- Roland DG Corporation assumes no responsibility for any direct or indirect loss or damage that may occur with respect to any article made using this product.

# Contents

<b>Basic Handling Methods</b> .....	<b>5</b>
Basic Information .....	6
Introduction .....	7
Items to Be Prepared .....	7
You Can Print This Way .....	8
Features of This Machine .....	9
Features of Inks .....	10
Part Names and Functions .....	11
Object to Be Printed On .....	16
Composition and Role of Software Used in the Machine .....	24
Head Gap Sensor .....	25
Deodorizer .....	26
Nozzle Drop-out Test .....	27
Alignment by Camera Image .....	29
Recommended Settings .....	30
Utility .....	35
Starting/Exiting Utility .....	35
Utility Home Screen .....	38
Menu List .....	40
Daily Overall Flow .....	48
Workflow .....	48
Basic Operations .....	49
Power Supply Operations .....	50
Turn on the sub power .....	51
Turn off the sub power .....	53
Sleep Mode (Power-saving Feature) .....	54
Turning the Power Off During Emergencies .....	55
Opening/Closing the Cover .....	56
Opening/Closing the Front Cover .....	56
Attaching/Removing the Maintenance Cover .....	58
Pausing and Canceling Printing .....	59
Pausing and Resuming Printing .....	59
Canceling Printing .....	60
<b>Printing method</b> .....	<b>61</b>
Preparations for Printing .....	62
Computer Preparations .....	63
Preparing Utility .....	63
Preparing the Machine .....	64
Step 1: Performing a Nozzle Drop-out Test .....	64
Step 2: Performing Normal Cleaning .....	66
Starting Printing .....	68
When Determining the Printing Position Manually .....	69
Step 1: Creating Printing Data .....	69
Step 2: Placing the Object .....	70
Step 3: Setting Up the Object .....	72
Step 4: Perform Printing .....	76
Determining the Printing Position Using Captured Images .....	77
Step 1: Alignment Marker Printing .....	77
Step 2: Placing and Imaging the Object .....	79
Step 3: Setting Up the Object .....	81
Step 4: Creating Data while Checking the Position .....	84

---

Step 5: Perform Printing .....	86
Print Parameters (FlexiDESIGNER).....	87
<b>Printing Examples .....</b>	<b>88</b>
Printing on Cosmetic Items .....	89
Step 1: Creating Printing Data .....	89
Step 2: Placing and Setting Up the Object .....	92
Step 3: Perform Printing .....	95
Printing on Golf Balls .....	96
Step 1: Creating Printing Data .....	96
Step 2: Placing and Setting Up the Object .....	99
Step 3: Perform Printing .....	102
Printing on Smartphone Cases .....	103
Step 1: Creating Printing Data .....	103
Step 2: Placing and Setting Up the Object .....	106
Step 3: Perform Printing .....	109
Printing on an Acrylic Stand .....	110
Step 1: Creating Printing Data .....	110
Step 2: Placing and Setting Up the Object .....	114
Step 3: Perform Printing .....	117
<b>Settings .....</b>	<b>118</b>
Efficiency Settings .....	119
Reducing Print Time .....	120
Minimizing Print-head Carriage Movement .....	120
Quality Settings.....	121
Flat Table Height Setting .....	122
Readjusting Height during Printing .....	123
Setting a Longer Distance between the Object and the Print Heads.....	126
Setting the Reference Position of the Flat Table in the Vertical Direction .....	128
White Ink Density Maintenance Settings .....	129
Setting the [Ink Circulation] Interval .....	129
Advanced Settings.....	130
Preferences .....	131
Removing/Attaching Optional Items (OA-RA-8).....	131
Setting the Deodorizer Mode .....	132
Setting the Deodorizer Pause Time (Strong Mode Only) .....	133
Setting the Activation Interval for Sleep Mode (Power-saving Feature) .....	134
Adjusting the Date and Time .....	135
Setting the Language .....	136
Setting the Base Position of the Manual Cleaning Tool .....	137
Adjusting the Pointer Position .....	139
Checking the Height of the Object before Printing .....	141
System Settings .....	142
Changing the Units of Measurement.....	142
Viewing Printer Information .....	143
Viewing Network Information .....	144
Checking the Utility Version .....	145
Changing the Network Settings.....	146
<b>Maintenance .....</b>	<b>154</b>
Introduction .....	155
Important Notes on Handling and Use .....	156
Printer Unit .....	156

---

Ink Cartridges .....	156
Basic Maintenance Knowledge .....	157
Automatic Maintenance Feature and Notes .....	157
Types and Timing of Maintenance.....	158
When Not in Use for a Prolonged Period .....	159
Action Taken When Dot Drop-out or Dot Displacement Occur .....	160
Action Taken When Uneven Color Issues Occur (White Ink).....	161
<b>Regular Maintenance .....</b>	<b>162</b>
Daily or Periodic Maintenance .....	163
Maintenance of Ink Cartridges.....	163
Cleaning the Machine .....	164
Normal Cleaning .....	165
Manual Cleaning .....	167
Cleaning the UV-LED devices .....	174
<b>Advanced Maintenance .....</b>	<b>177</b>
Maintenance to Perform When Problems Occur.....	178
Medium Cleaning .....	178
Powerful Cleaning .....	180
Ink Renewal .....	182
Ink Discharge .....	183
<b>Replacing Consumable Parts.....</b>	<b>184</b>
Replacing Ink Cartridges .....	185
Out-of-ink Warnings .....	185
Replacing Ink Cartridges.....	186
Replacing Parts for Maintenance .....	188
Replacing the Drain Pack .....	188
Replacing the Wiper.....	192
Replacing the Felt Wiper .....	194
Replacing the Cap Top .....	196
Replacing the Deodorizer Filter .....	202
<b>Troubleshooting .....</b>	<b>204</b>
Troubleshooting Methods.....	205
Print Quality Problems .....	206
Print Results Are Coarse .....	206
Print Results Contain Horizontal Bands .....	207
Colors Are Unstable or Uneven.....	208
The Object Becomes Soiled.....	209
Excessive Misting / Nozzle Drops Out / Ink Smearing or Dripping .....	210
Ink Adhesion Is Poor .....	211
Printing Position Using Alignment Markers Is Misaligned .....	212
Alignment Markers Cannot Be Read .....	214
Machine Problems.....	216
The Printer Unit Does Not Run (Does Not Print) .....	216
Why Has the Print-Head Carriage Stopped Moving? .....	218
The Flat Table Does Not Move .....	220
Network Trouble .....	221
Printer Is Not Displayed on the Roland DG Connect Hub .....	221
Roland DG Connect Hub Does Not Change from "Loading" .....	221
<b>Frequently Asked Questions .....</b>	<b>222</b>
Quality Improvement Section.....	223
Printing on a Thick, Transparent Object.....	223
Printing Without Being Affected by the Color of the Object (White Printing on a Base).....	224

---

Printing on an Uneven Surface .....	225
Useful Functions Section.....	226
Printing Using Commercially-available Application Software.....	226
<b>Utility Notification/Errors/Fatal Errors.....</b>	<b>227</b>
Notifications .....	228
[When output, cleaning, and other operations are completed, discard the discharged fluid.] .....	228
[The drain cartridge was removed.] .....	228
[The time for manual cleaning has arrived.].....	228
[Perform manual cleaning.] .....	229
[The time for wiper replacement has arrived.] .....	229
[The time for felt wiper replacement has arrived.].....	229
[The time for cap top replacement has arrived.].....	229
[Print head protection mode has activated.] .....	229
[The time for ink mixing has arrived.] .....	229
[The connection to the unit was lost.].....	230
[There is ink that has expired.] .....	230
[The time for manual cleaning of the UV lamp has arrived.].....	230
ERROR .....	231
[Ink Cartridge Error] .....	231
[Cover Open Error].....	231
[Manual Cleaning Tool Error].....	231
[Rotary Mode Mismatch Error].....	232
[Flat Table Height Error] .....	232
[Print Data Larger Than Printing Area] .....	232
[Insufficient Printing Area] .....	232
[Manual cleManual Cleaning Required for Printinganing required] .....	232
[Replace the drain pack.].....	232
Fatal Error .....	234
[Service Call: ] .....	234
[Motor Error: ] .....	234
[Print Head Dry-out Error].....	234
[Low Temperature Error: ] .....	234
[High Temperature Error: ] .....	234
[Pump Stop Error] .....	235
[Emergency Stop Error] .....	235
<b>Appendix.....</b>	<b>236</b>
Move.....	237
Preparing to Move the Machine.....	238
Procedures from Preparing to Move to Reinstallation .....	238
Main Specifications .....	242
Dimensional Drawings .....	243
Outer Dimensions.....	243
Flat Table Dimensions.....	244
Specifications.....	245

# **Basic Handling Methods**

# Basic Information

---

Introduction .....	7
Items to Be Prepared .....	7
You Can Print This Way .....	8
Features of This Machine .....	9
Features of Inks .....	10
Part Names and Functions .....	11
Object to Be Printed On.....	16
Composition and Role of Software Used in the Machine .....	24
Head Gap Sensor .....	25
Deodorizer.....	26
Nozzle Drop-out Test .....	27
Alignment by Camera Image.....	29
Recommended Settings.....	30
Utility.....	35
Starting/Exiting Utility .....	35
Utility Home Screen .....	38
Menu List .....	40
Daily Overall Flow .....	48
Workflow .....	48

# Introduction

## Items to Be Prepared

Prepare the following before using this product.

- **Protective equipment (glasses and gloves)**

Use protective equipment when performing maintenance. Be sure to use a size that fits you properly.

- **Anhydrous ethanol or isopropyl alcohol**

Used for degreasing printed objects and cleaning the UV-LED device.

- **Cloth (that is not fluffy)**

Used for cleaning machines, degreasing printed objects, and cleaning the UV-LED device.

- **Nozzle drop-out test paper**

Used for nozzle drop-out test of print heads.

- **Masking tape**

Used as masking tape for securing objects and preventing ink mist. It is also used to print alignment markers when using a smartphone camera to specify the printing position.

- **Static removal brush, static removal cloth, and other static removal tools**

Used when the object is charged with static electricity, such as when the temperature and humidity are low or when printing with the protective film removed.





### RELATED LINKS

- [P. 174 Cleaning the UV-LED devices](#)
- [P. 27 Nozzle Drop-out Test](#)
- [P. 77 Alignment Marker Printing](#)



## You Can Print This Way

You can use this machine to print as shown below. We will also guide you through the steps from creating print data to printing, so refer to this section as a reference when using this machine.

<p style="text-align: center;"><b>Cosmetic Items</b></p>  <p>Procedure up to Printing: <a href="#">Printing on Cosmetic Items(P. 89)</a></p>	<p style="text-align: center;"><b>Golf Ball</b></p>  <p>Procedure up to Printing: <a href="#">Printing on Golf Balls(P. 96)</a></p>
<p style="text-align: center;"><b>Smartphone Cases</b></p>  <p>Procedure up to Printing: <a href="#">Printing on Smartphone Cases(P. 103)</a></p>	<p style="text-align: center;"><b>Acrylic Stand</b></p>  <p>Procedure up to Printing: <a href="#">Printing on an Acrylic Stand(P. 110)</a></p>

## Features of This Machine

This machine uses UV ink and then irradiates with UV light after printing to cure and adhere the ink.

You can use the flat table to print on a range of objects, from thin paper to thick objects. This machine is also equipped with a deodorizer to reduce the odor of the UV ink.

The differences from a generic printer are as follows:

- **The print-head carriage and flat table move.**

The print-head carriage (A) moves left to right (S: scan direction) and the flat table (B) moves back and forth (F: feed direction) to print. The flat table moves up and down to adjust the printing surface (position in height direction). However, it is not possible to print on an inclined print surface while changing the height.

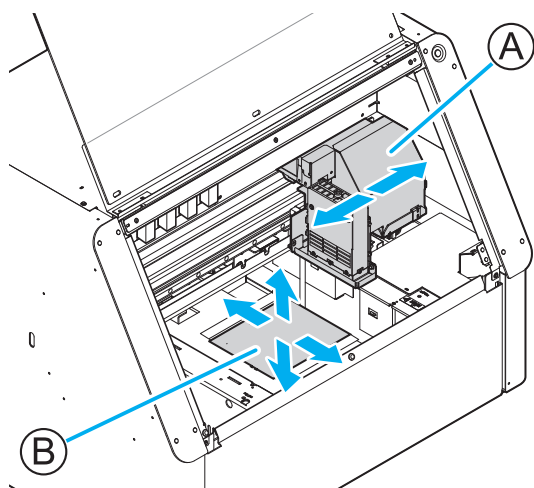

- **You can set the height and printing position of the print surface.**

The head gap sensor (A) detects the height of the object placed on the flat table, and then adjusts the height of the print surface (the height direction position of the flat table) to ensure high image quality and safe printing. You can also use the pointer (B) to precisely specify the printing area.

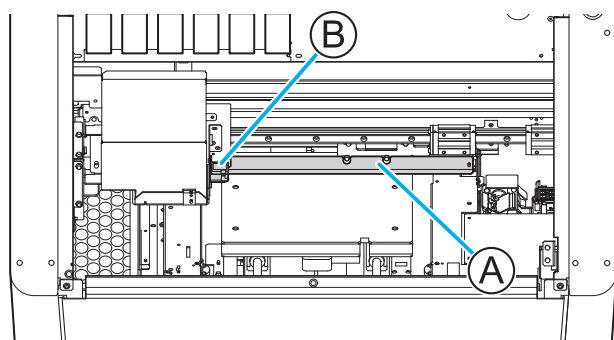

---

## Features of Inks

This machine prints using ECO-UV (EUV5) inks and primers. This section explains their respective features.

### Features of ECO-UV (EUV5) Inks

This printer uses ECO-UV (EUV5) inks. ECO-UV (EUV5) inks are fixed to the object instantly by ultraviolet light. This makes it possible to print on materials\*<sup>1</sup> that are difficult to print on using conventional inks.

This printer has one ink type in five colors (cyan, magenta, yellow, black, and white) and a primer.

### Features of Primer

The primer is a colorless and transparent coating agent used as an ink base. Ink adhesion may be improved even on materials that are difficult to print on with EUV-5 ink.

Materials that are generally difficult for ink to adhere to include the following.

- Metal
- PET (polyethylene terephthalate)
- PP (polypropylene)
- PE (polyethylene)
- Silicone
- Acrylic
- Glass

Of these, inks adhere better to metals, PET, acrylics, and glass when a primer is used. However, if the surface is coated or painted with a glass coating, water repellent treatment, stain resistant treatment, or similar, it will be difficult to improve adhesion.

It is difficult to identify any processing or treatment to the surface of a material, even if it seems to be a material for which primer would be effective. Be sure to test print on the actual object to check ink adhesion. Do not proceed with actual printing without first confirming the efficacy of the primer.

---

\*1 Some materials and surface finishes cannot be printed on.

## Part Names and Functions

### Front

#### TOP

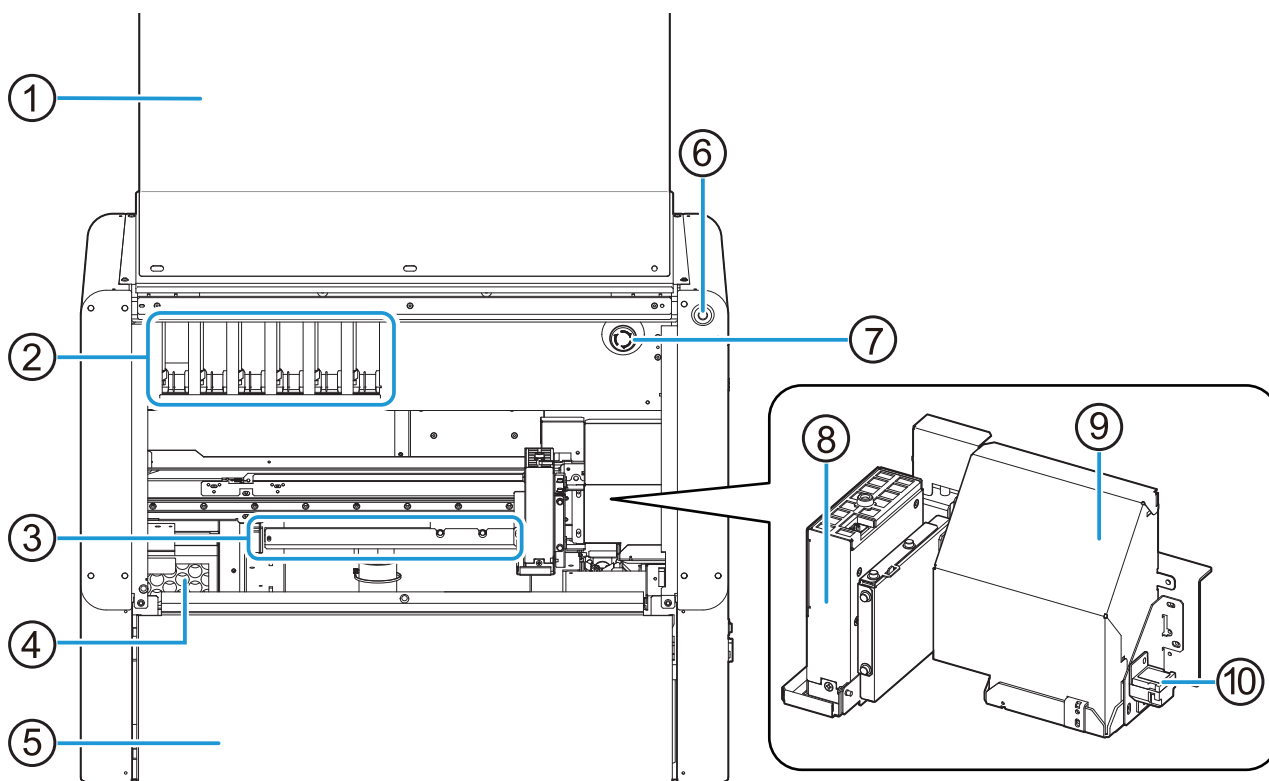

No.	Name	Function overview
①	Front cover	Prevents contact with the print-head carriage and other such fast-moving parts when the machine is operating. This cover also reduces dust and keeps UV light and odors out. Keep it closed except when placing objects or when performing maintenance.
②	Ink slots	Ink cartridges are inserted into these slots.
③	Head gap sensor	Detects the height of the object to be printed on.
④	Deodorizer	Eliminates UV ink odor.
⑤	Maintenance cover	Remove the maintenance cover when replacing the drain pack, cleaning the UV-LED device, or removing and installing the optional items (OA-RA-8). Keep it closed except when it is necessary to open it.
⑥	Sub power button	Switches the sub power of the machine on/off.
⑦	Emergency stop button	This button allows you to stop the machine immediately when it performs an action you did not intend.
⑧	UV-LED device	Shines the UV light used to cure the ink.
⑨	Print-head carriage	The print heads are inside this carriage.
⑩	Pointer	Illuminates in the direction of the flat table with LED light that indicates the print origin or printing area.

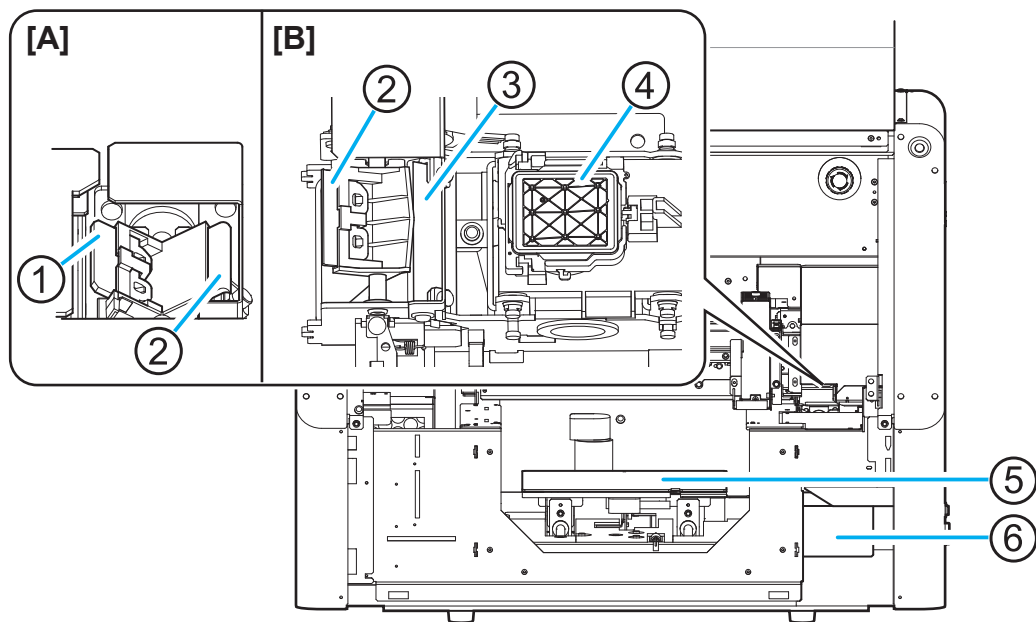
**Bottom**

[A]: Standard Position [B]: Manual Cleaning Position

No.	Name	Function overview
①	Felt wiper	Cleans the edges of the print heads after wiper operation. Absorbs residual ink and dirt from the edges of the print heads.
②	Wiper	Cleans the print heads. Removes dirt and excess ink from the print heads.
③	Scraper	Removes ink and dirt that have adhered to the wiper.
④	Cap top	Prevents the print heads from drying out. Seals to the print heads to protect the ink emission surface when the print-head carriage is at the right side of the machine, such as when waiting for printing.
⑤	Flat table	Table on which the object is placed.
⑥	Drain cartridge	Accumulates the discharged ink. If the drain pack in this cartridge is full of discharged fluid, a message prompting you to replace the pack will appear in the Utility window. If this message appears, replace the drain pack in the drain cartridge.

**⚠ CAUTION**

**Do not place your hands on or touch the flat table or inside the machine (except for the cartridge slots).**

Doing so may cause burns.

**⚠ CAUTION**

**Do not place any objects in front of or behind the flat table.**

The flat table moves horizontally and vertically. If there is an object between the flat table and the machine, it can be caught and cause the machine to malfunction.

## Side

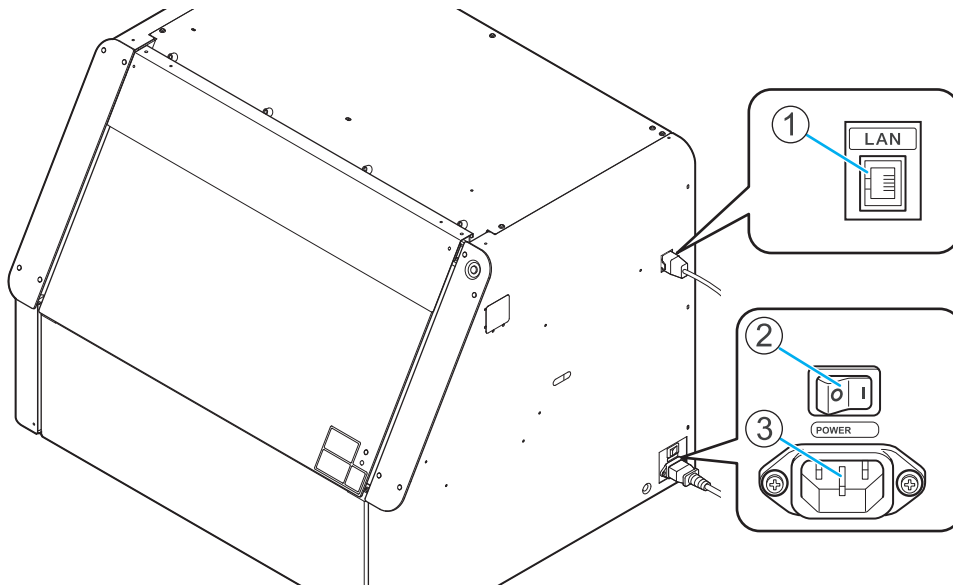

No.	Name	Function overview
①	Ethernet connector	Use this to connect an Ethernet cable.
②	Main power switch	Switches the main power of the machine on/off.
③	Power-cord connector	Used to connect the power cable from which power is supplied to the machine.

## Manual cleaning tool

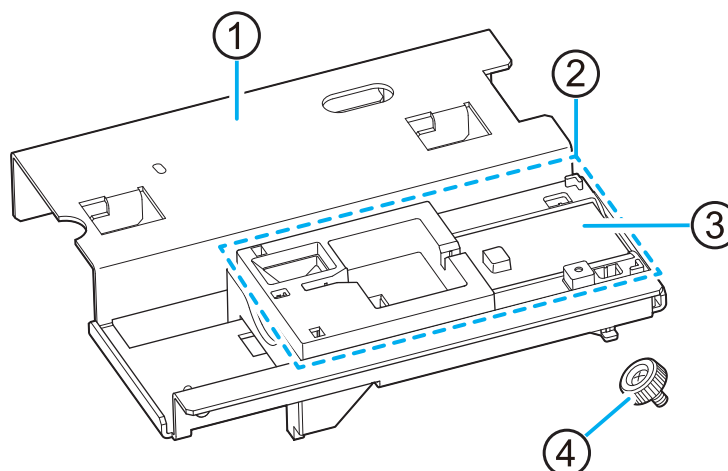

No.	Name	Function overview
①	Manual cleaning tool body (fixed part)	Attach this to the machine during manual cleaning.
②	Cleaning part (moving parts)	This is the part that moves when the cleaning stick is attached and manual cleaning is performed.
③	Pad	Absorbs cleaning liquid or discharged fluid that drips from the cleaning stick.
④	Manual cleaning tool retaining screw	Fixes the manual cleaning tool to the machine.

### IMPORTANT

Do not use the manual cleaning tool if it is deformed due to hitting something or being dropped. In this situation, replace this tool.

Using a deformed manual cleaning tool may prevent the normal operation of manual cleaning or may damage the machine.

### MEMO

- We recommend that the manual cleaning tool be left in front of the deodorizer when not in use.
- We recommend keeping the manual cleaning tool retaining screw in the area shown in the figure to prevent loss.

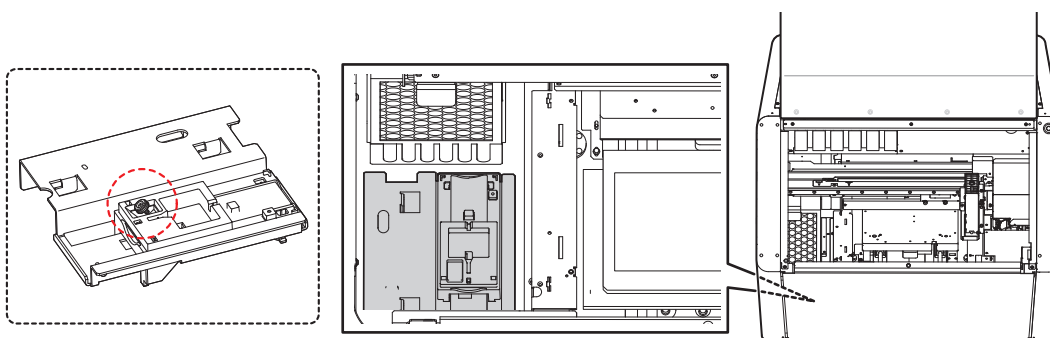

## Machine State Indicated by the Sub Power Button's Lamp

The machine states are indicated with sub power button colors and flashing patterns. The sub power button allows you to check the state of the machine at a distance.

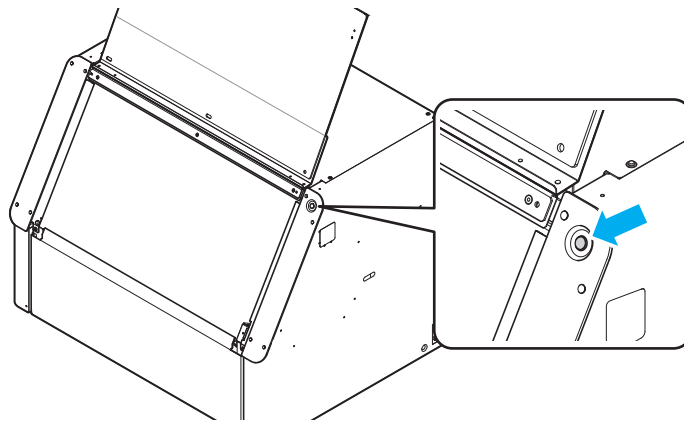

Lamp	Machine state
● Off	Power off
● Lit in green	Printing
● Lit in blue	Object has not been set up, such as during maintenance operations.
● Flashing in blue	The machine is starting or is in sleep mode.
● Lit in yellow	Setup of the object is completed, and it is ready for printing.
● Flashing in yellow	The machine is paused.
● Lit in red	When an abnormality occurs in the machine, or when the emergency stop button is pressed.



## Object to Be Printed On

In this manual, the objects to be printed are called the "object" or "media." Although this machine can print on a variety of objects, from thin paper to thicker materials, there are some regarding the object that you should take into consideration.

### Objects that Can Be Set Up

The conditions for objects that can be set up in the machine are shown below.

#### Size and Weight

The printable range differs from the printable object to be set up. You can set up objects that are larger than the [Printable Area](#).

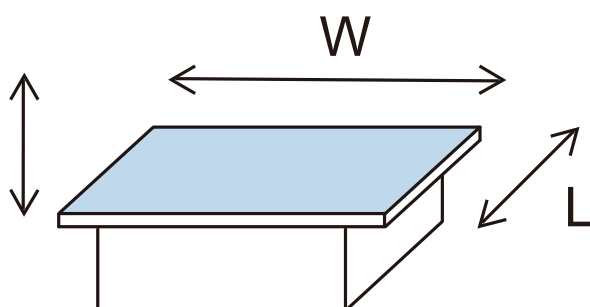

Maximum size	Width (W)	240 mm (9.45 in.)
	Length (L)	178 mm (7.01 in.)
	Thickness	102 mm (4.02 in.)* <sup>1</sup>
Maximum weight		3 kg (6.61 lb.)

- \*1
- Except when using the optional rotary axis unit.
  - Depending on the object, it may be possible to print up to 107 mm (4.21 in.).

#### Materials, Shapes, and Similar Parameters

Although this machine can print on many materials, be sure to test print and then check the ink adhesion before printing the final print. In addition, to protect the print heads and ensure print quality, the following objects cannot be printed on.

- **Mirrors, stainless steel, and other objects that are likely to reflect UV light**  
These objects promote the curing of the surface of the print heads and therefore cannot be used.
- **Objects that are charged with static electricity**  
Static electricity can cause the ink to splatter, adversely impacting printing results and the print heads.
- **Objects with significant unevenness on the print surface**  
The greater the distance between the print heads and the print surface, the worse the printing results. The difference between the highest and lowest print surfaces should be approximately 2 mm (0.08 in.) or less.
- **Objects that easily become loose**  
If the object (A) is not firmly held in place, the head gap sensor (B) cannot detect the height correctly. Be sure to secure the object to be printed on firmly in place. If the media becomes loose, you can use masking tape or similar to hold the media in place.

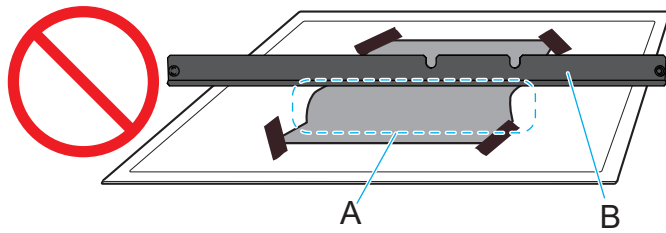

- **Objects made from soft material**

If the object (A) is made from soft material, the pressure it applies on the head gap sensor (B) is too weak. This prevents its height from being detected correctly.

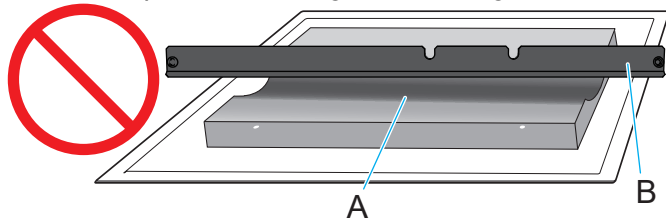
**IMPORTANT**

Depending on the type of object to print on and the installation method, the height may not be set correctly. The machine may malfunction if printing is performed when an incorrect installation method is used or if printing is performed on an inappropriate material.

## Printable Area

The maximum printable area is as follows.

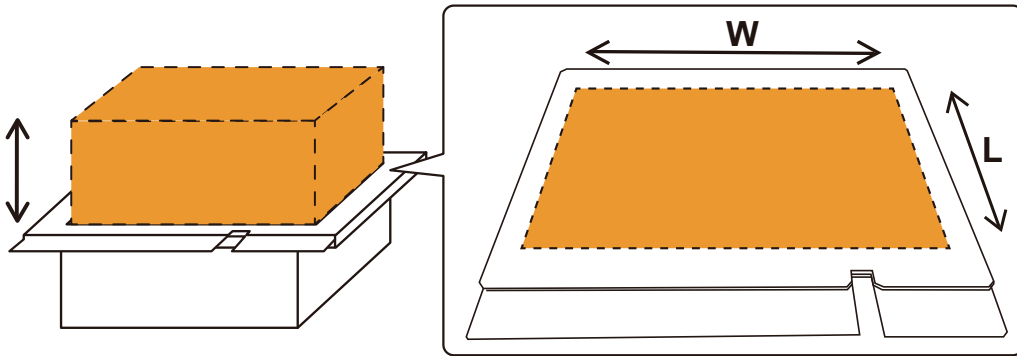

Width (W)	210 mm (8.2 in.)
Length (L)	148 mm (5.83 in.)
Height	0 to 102 mm (0 to 4.02 in.) <sup>*1</sup>

- \*1
- Except when using the optional rotary axis unit.
  - Depending on the object, it may be possible to print up to 107 mm (4.21 in.).

### Front/Back/Left/Right Printing Area

The area within the white border of the flat table is the approximate maximum printing area. The machine uses the lower right of the flat table as the 0 point (A) and then 0 mm (0 in.) in the S: scan direction and 0 mm (0 in.) in the F: feed direction. The upper left corner (B) of the flat table is S: 210 mm (8.26 in.) and F: 148 mm (5.82 in.), and the area between these two points is the maximum printing area.

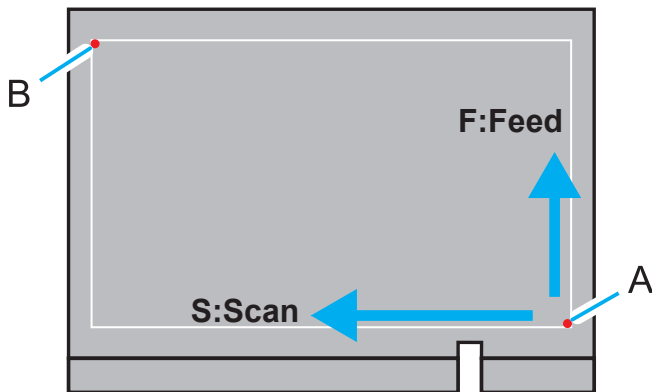

S and F set in Utility indicate the coordinates of the flat table. The printing area set based on the print origin (C) and the upper left corner (D) is displayed as "W" (length in the S direction) and "L" (length in the F direction). In the case shown in the following figure, if C (S: 110 mm [4.33 in.], F: 70 mm [2.76 in.]) and D (S: 210 mm [8.27 in.], F: 148 mm [5.83 in.]) are used, the printing area is W: 100 mm (3.93 in.) and L: 78 mm (3.07 in.). The minimum settable printing area is W: 25.4 mm (1 in.) and L: 25.4 mm (1 in.).

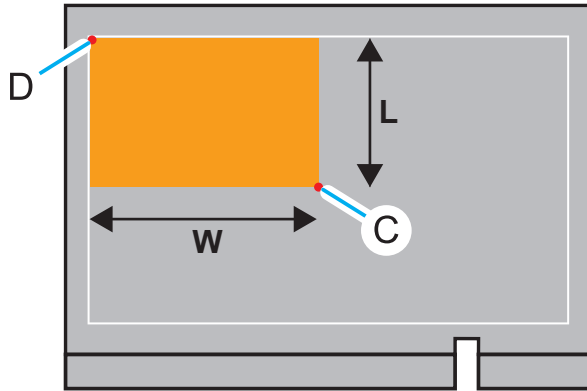

### Printing Area in the Height Direction

The printing area is within 2 mm (0.08 in.) (b) from the highest printing position (a) of the object. Printing positions (c) that are 2 mm (0.08 in.) or lower are not recommended due to lower print quality.

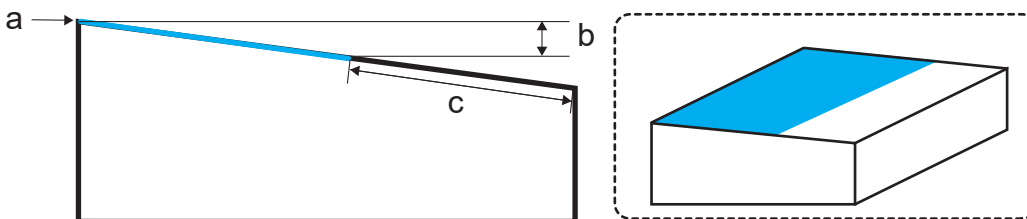

However, print quality may improve depending on the settings at the time of printing. Set the following based on the height of the print surface.

- [General] or [Text Decoration]: Difference in height of printed surface is within 2 mm (0.08 in.)
- [Generic Distance]: 2 mm to 6 mm (0.08 in. to 0.23 in.) difference in height of printed surface (2 mm to 4 mm [0.08 in. to 0.15 in.] if Wh is included in the printing)

## Orientation of Object and Print Data

Print data is printed with the data rotated 180 degrees. When setting up the object in the machine, rotate it 180° relative to the print data.

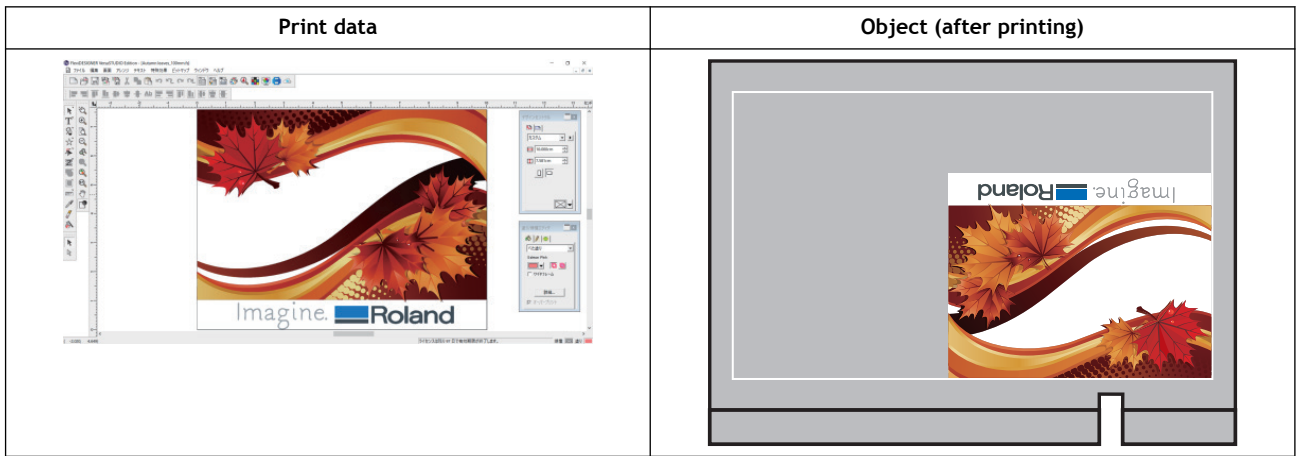

## Considering a Jig

As the distance between the object and the print heads increases, the likelihood of ink mist\*<sup>1</sup> increases. Therefore, a jig might be required according to the size and shape of the object to be printed on. Prepare a jig if one of the following conditions is met.

If it is difficult to obtain a jig, cover the sides of the object with masking tape or similar to avoid adhesion of ink mist.

**When with just the object, no margins can be secured in the areas 40 mm (1.57 in.) to both the front/back and left/right of the portion of the data to be printed**

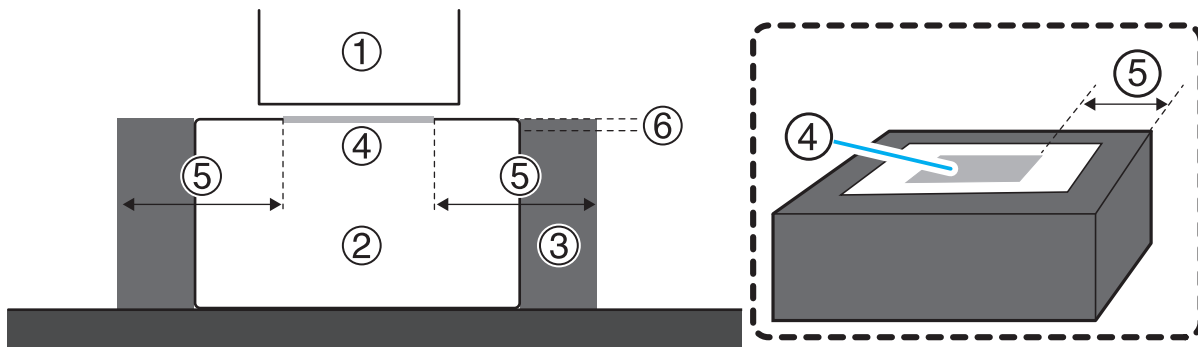

①	Print heads	④	Data area
②	Object to be printed on	⑤	Margin: 40 mm (1.57 in.) or more
③	Jig	⑥	Less than 2 mm (78.7 mil) in height difference from the actual print surface

**The variation in height of the surface of the object is 2 mm (0.08 in.) or more**

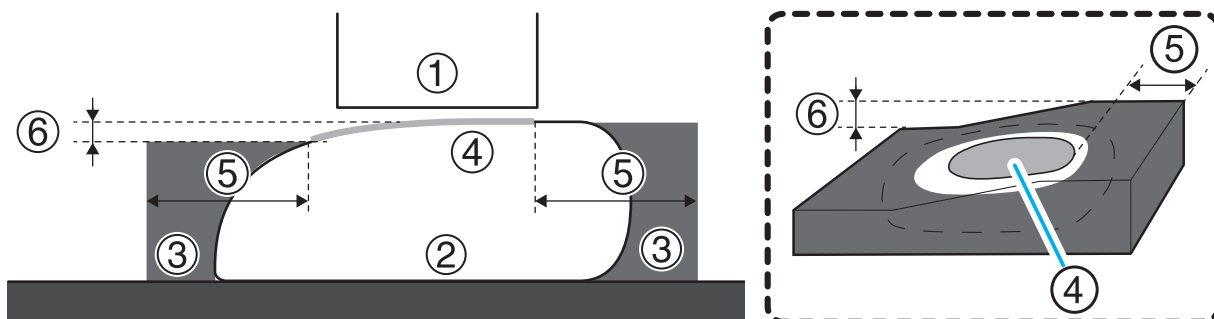

①	Print heads	④	Data area
②	Object to be printed on	⑤	Margin: 40 mm (1.57 in.) or more
③	Jig	⑥	Less than 2 mm (78.7 mil) in height difference from the actual print surface

\*1 Fine particles of ink are scattered in areas other than the printing area.

## Object (Media) Registration Items

Set the following items to set up the object.

### Object Type

Select from **[Transparent]** or **[Opaque]**. For colored transparent objects, select based on the following criteria.

- **[Transparent]**: A hand placed on the other side of the object can be seen through it.
- **[Opaque]**: A hand placed on the other side of the object cannot be seen through it.

#### IMPORTANT

The **[Transparent]** and **[Opaque]** selections affect automatic maintenance. The standard setting **[Transparent]** requires more frequent maintenance\*<sup>1</sup> to protect the print heads than **[Opaque]**, and therefore consumes more ink. Proper selection of **[Transparent]**/**[Opaque]** can reduce ink consumption and prevent poor printing quality.

### Flat table height

Set the printing position in the height direction.

### Print Origin

Set the point that will serve as the base printing position. Select one of the following.

- **[Origin Relative]**: Sets the lower-right corner of the printing area as the base printing position.
- **[Center Relative]**: Sets the center of the printing area as the base printing position.

### Printing Area

#### IMPORTANT

The printing area should be set after the flat table height is set. Attempting to set the printing area first may result in the object coming into contact with the head gap sensor, which may damage the head gap sensor.

Specify the area in which to print. There are two ways to set the area depending on the print origin.

- When **[Origin Relative]** is set for **[Print Origin]**: If you specify the lower right corner (A) of the preview window in Utility, the space between the end point (B)\*<sup>2</sup> is set as the printing area.

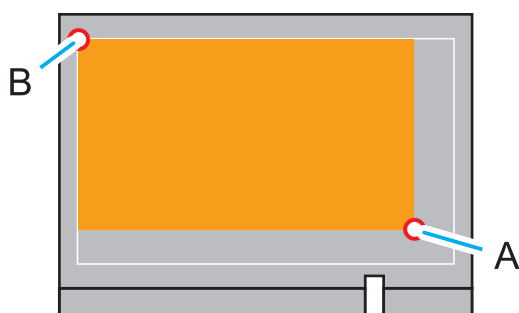

- When **[Center Relative]** is set for **[Print Origin]**: The maximum printing area is set around the center of the printable area (S: 105 mm [4.13 in.], F: 74 mm [2.91 in.]).

#### MEMO

When changing the **[Center Relative]** position, narrow the printing area before changing the position. Then specify the printing area according to the print data.

\*1 Performs cleaning using ink.

\*2 Upper left of printable area (S: 210 mm [8.27 in.], F: 148 mm [5.83 in.])

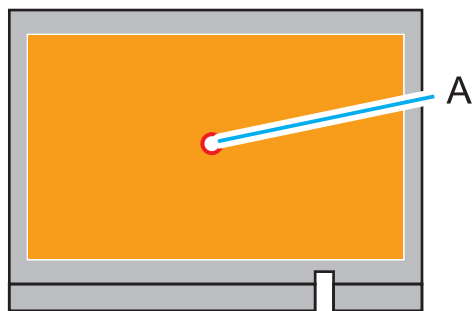



## Composition and Role of Software Used in the Machine

The machine is operated by Utility, which is started from the Roland DG Connect Hub. Creation of print data, processing (resizing, decorations such as text and pattern), detailed settings, and printing are performed using FlexiDESIGNER VersaSTUDIO Edition, but the actual print data is generated using VersaWorks.

### Composition

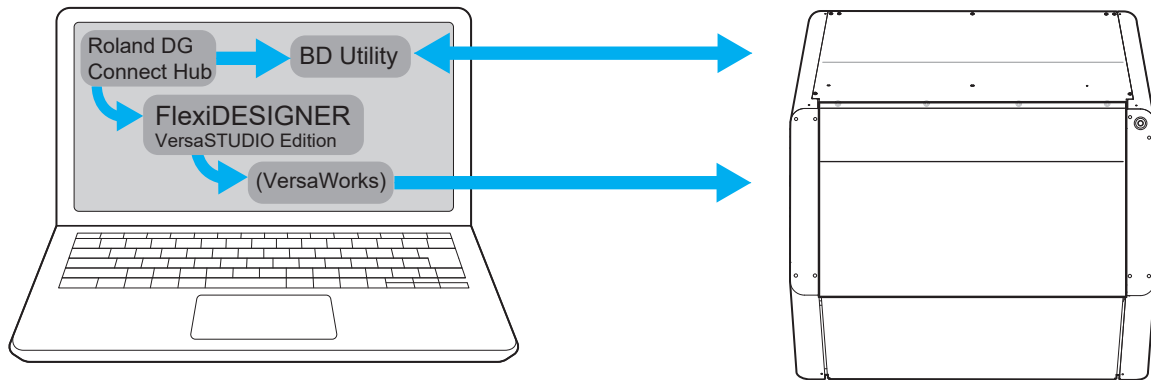

### [Utility]

This software displays the printer status and configures the printer settings. It mainly performs the following operations.

- Setting and adjustment functions
- Management of ink remaining amount
- Maintenance function
- Display of messages and error messages

### [FlexiDESIGNER VersaSTUDIO Edition]<sup>\*1</sup>

This software handles everything from the creation of print data to printing.

### [VersaWorks]

This software converts print data into data that can be printed using a printer.

When FlexiDESIGNER is started, VersaWorks is launched along with it, but when printing from FlexiDESIGNER, this software is not operated directly. However, since VersaWorks is generating the print data, it should be left running when printing.

### MEMO

When print data is created by utilizing existing data (.ai, .pdf, etc.) or by using commercially available application software<sup>\*2</sup>, VersaWorks is used to make the necessary settings for printing, and then perform printing.

### RELATED LINKS

- [VersaWorks Help](#)

\*1 Hereinafter referred to as "FlexiDESIGNER."

\*2 Software for creating vector graphics such as Adobe Illustrator and CorelDRAW.

## Head Gap Sensor

The head gap sensor is an important sensor that detects the height of the object. Improper setup of the object to be printed or problems with the way the object is secured may result in damage to the head gap sensor.

### Object Height Detection Method

The flat table (A) moves from the back to the front and the head gap sensor (B) comes into contact with the object (C) to detect the height of the object.

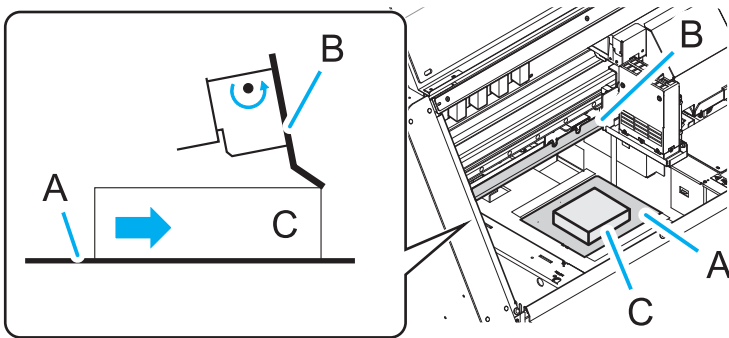

### Risk of Head Gap Sensor Damage

After detecting the height of the object, the clearance between the object (A) and the head gap sensor (B) is set to 0.5 mm (0.02 in.).

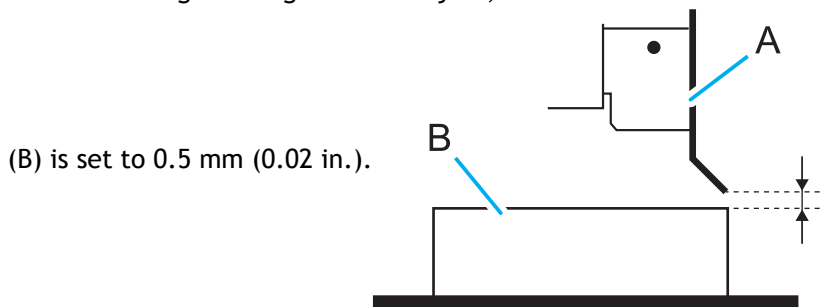

However, note that the following operations or situations may cause the object to come in contact with the head gap sensor and damage it.

- The top point of the object is higher than the head gap sensor.

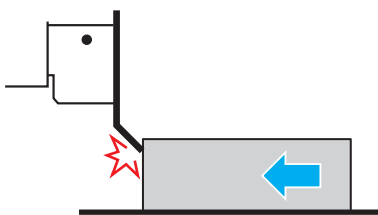

- The flat table is moved from front to back in an attempt to set the printing zone before setting the height of the object.
- Media with a lower height than the installed object is selected, and the printing area is set and printing begins without the user noticing the selection error.
- The flat table is moved from the front to the back while the object is not firmly secured to the flat table (i.e., the height of the object may change).
- After fixing a warped object with tape and setting the height, the tape partially peels off due to the warping, and the object strikes the head gap sensor when the flat table moves.
- The rotary axis unit is not recognized.
  - The rotary axis unit is installed on the flat table, but the connector of the rotary axis unit is not connected to the main unit or is not connected correctly.

## Deodorizer

Since UV ink has an odor that may affect the human body, this machine is equipped with a deodorizer.

The deodorizer has four modes, as shown in the table below. Since there is a trade-off between the service life of the filter and its deodorizing performance, use the filter as appropriate for your usage situation.

Deodorizing performance varies depending on the mode and suction power. Each mode has a default suction power setting, which can then be set from 20% to 100% in 10% increments.

For information about purchasing filters, contact your authorized dealer or visit our website.

Mode	Deodorizing performance	Suction power default settings
[Strong]	Activated when main power is on, sub power is on, or during printing. This setting emits the least amount of odor to the exterior of the machine. This mode reduces odors coming out of openings in the machine even when the machine is not in use. In this mode, you can set the pause time for the deodorizer.	<ul style="list-style-type: none"> <li>• [When Printing]: 50%</li> <li>• [When Sub Power On]: 40%</li> <li>• [When Main Power On]: 20%</li> </ul>
[Medium]	Activated when sub power is on, or during printing. This mode reduces odors when the front cover is opened during operations such as loading objects.	<ul style="list-style-type: none"> <li>• [When Printing]: 50%</li> <li>• [When Sub Power On]: 40%</li> </ul>
[Weak] <sup>*1</sup>	Activated only during printing. This mode is intended for users in backyards and other areas that are normally unoccupied and well-ventilated.	<ul style="list-style-type: none"> <li>• [When Printing]: 50%</li> </ul>
[Off]	Deodorizing not activated.	—

\*1 Default settings

### MEMO

- Recommended Filter Replacement Time
  - Once every year.  
However, the deodorizing performance decreases with frequency of use. If you start to smell odors coming from near the machine, replace the filter even if it has been in use for less than a year.

### RELATED LINKS

- [P. 132 Setting the Deodorizer Mode](#)
- [P. 133 Setting the Deodorizer Pause Time \(Strong Mode Only\)](#)
- [P. 202 Replacing the Deodorizer Filter](#)
- [Roland DG Website](#)

## Nozzle Drop-out Test

### Test Pattern and Details Checked

Before printing, perform a nozzle drop-out test (print a test pattern). The printing size for the test pattern is approximately 90 × 51 mm (3.54 in. × 2.01 in.) (landscape).

If you prepare a landscape A5 size (210 mm × 148 mm (8.27 in. × 5.83 in.)) paper as the media, you can perform nozzle drop-out tests in up to four locations on a single sheet of media.

Print the test pattern using inks as indicated in the sequence below. You can check if the print heads are functioning normally.

#### MEMO

The primer (Pr) and white (Wh) in this figure are deliberately made gray, but the actual test pattern Pr is printed transparent and Wh is printed white. These two will be harder to see than the following figure when printed on white media.

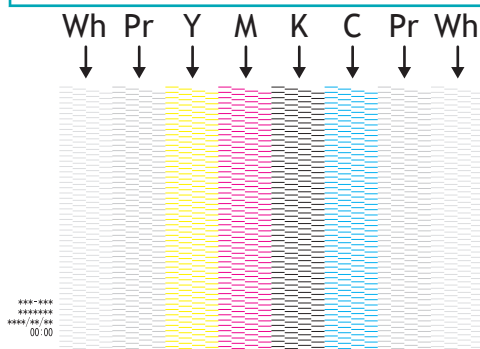

Make sure that the lines of each color are clear and evenly aligned. Missing sections in the test pattern indicate "dot drop-out," while a collapsed or sloping test pattern indicates "dot displacement." Such issues can be improved by eliminating the nozzle clogging. For this reason, several cleaning menus have been provided.

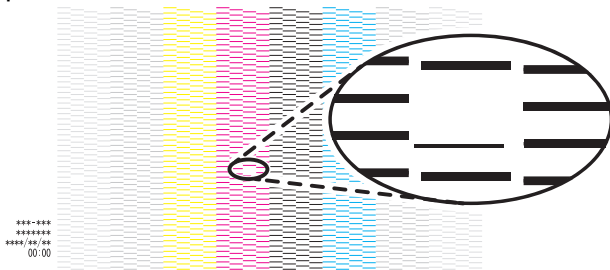

### Test Paper

The nozzle drop-out test is a task that should be performed frequently. If a problem is found by checking the test pattern, cleaning is performed and the nozzle drop-out test is performed again. Because of this, ease of checking and ease of loading media are important. The ease of checking depends on the color of the media.

To check the test pattern without removing the media and perform the nozzle drop-out test again after cleaning, the [Print Origin] must be set again.

#### Media Color

Media color	Features
Transparent	Since the flat table is black, check the test pattern by removing the nozzle drop-out test paper. Pr is transparent, but you can check it by its light transmission state. Once the media is removed, all colors can be easily checked. Some media are weakly adhesive and easy to reapply.
White	CMYK inks can be checked while media are attached to the flat table. Wh and Pr can be checked by removing them and changing the angle at which they are exposed to light.

## Introduction

---

Media color	Features
Black	Wh can be checked while media are attached to the flat table. All except Wh can be checked by removing the media and changing the angle at which it is exposed to light.
Silver	It is relatively easy to check the test patterns for all colors with the media attached to the flat table. A matte finish makes it even easier to check.

### How to Secure the Media

How to secure the media	Features
Tape	Fix the four corners or the entire circumference of the media with masking tape or similar. Tape the media closely to the flat table so that the media does not become loose. Apply the tape itself so that it does not become lifted or overlapped, creating a difference in height. If you remove the media and then check the test pattern, reloading it will require the same amount of time and effort as the first time.
Double-sided tape	Apply thin double-sided tape to all sides of the media and secure it to the flat table. Apply the double-sided tape starting from the edges so that the media does not become wrinkled or loose. When removing the media, be careful not to leave any double-sided tape on the flat table. Reloading is easier than with ordinary tape.
Media with weak adhesive sheet	Both loading and removing can be done easily.

## Alignment by Camera Image

You can use your smartphone's camera to specify the printing position on the object before printing. The flow of this operation is as follows.

1. Print the printing markers for detecting positions on the flat table.
2. Place the object on the flat table, and then take a picture of it with your smartphone.
3. Transfer the captured image data to your computer, and then import it with FlexiDESIGNER.
4. Position the print data on the image data and print it.

Compared to the usual printing method, in which the printing area is set by placing the object with reference to the white border of the flat table, alignment is easier since the position is specified from the imported image data. In addition, you can create print data with an image of the finished product in mind.

However, the printing position may misalign when printing on thicker objects or depending on the angle at which the pictures taken with the camera. Therefore, it is not suitable for printing over the entire printing area. We recommend using this method to print a small single point on a large printing area.

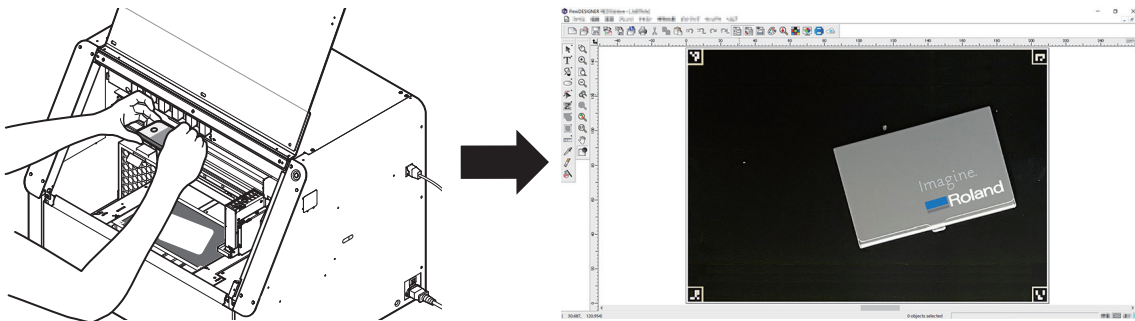

For details on this work, refer to [Determining the Printing Position Using Captured Images](#).

## Recommended Settings

### Introduction

- **Language settings and date/time settings**
  - Language settings:[Setting the Language\(P. 136\)](#)
  - Date/time settings:[Adjusting the Date and Time\(P. 135\)](#)
- **Deodorizer settings**
  - [Pausing and Resuming Printing\(P. 59\)](#)
- **Length and temperature units**
  - [Changing the Units of Measurement\(P. 142\)](#)
- **Nozzle drop-out test paper registration**
  - [Registering and Setting Up the Nozzle Drop-out Test Paper\(P. 31\)](#)

### Once You Are Experienced

- **Printing movement range**
  - [Minimizing Print-head Carriage Movement\(P. 120\)](#)
- **Clearance mode**
  - [Setting a Longer Distance between the Object and the Print Heads\(P. 126\)](#)
  - [Readjusting Height during Printing\(P. 123\)](#)
- **Ink circulation interval**
  - [Setting the \[Ink Circulation\] Interval\(P. 129\)](#)
- **Sleep time**
  - [Setting the Activation Interval for Sleep Mode \(Power-saving Feature\)\(P. 134\)](#)

## Registering and Setting Up the Nozzle Drop-out Test Paper

We recommend registering the media to be used for the nozzle drop-out test in order to operate the machine efficiently.

If you register a landscape A5 size (210 mm × 148 mm [8.27 in. × 5.83 in.]) paper as the media, you can perform nozzle drop-out tests in up to four locations on a single sheet of media by changing the [Print Origin].

### Procedure

1. Press the sub power button.  
P. 51 Turn on the sub power

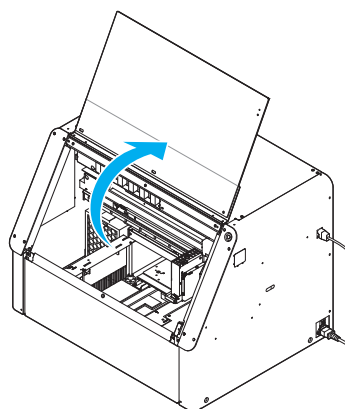

2. Open the front cover.

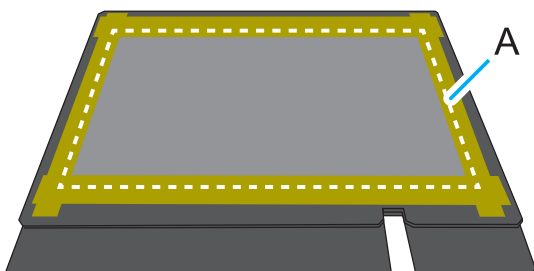

3. Pull out the white ink cartridge and mix it.  
Shake it about 50 times (for approximately 20 seconds), and then reinsert it.  
P. 163 Maintenance of Ink Cartridges

4. Load the nozzle drop-out test paper.  
The area inside the white line (A) is the approximate maximum printing area. Place and secure the media in alignment with the white frame. Secure it here with tape.



5. Close the front cover.
6. On the Utility home screen, click  [Setup].
7. Click .



## MEMO

In Utility, "media" is used on the window used to register/manage objects.

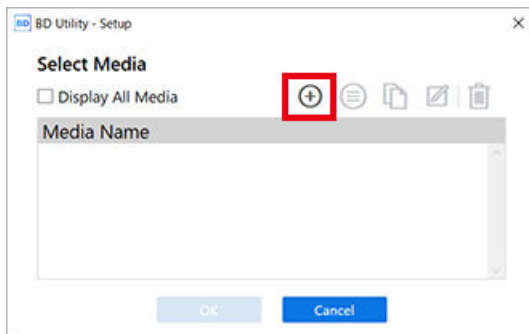

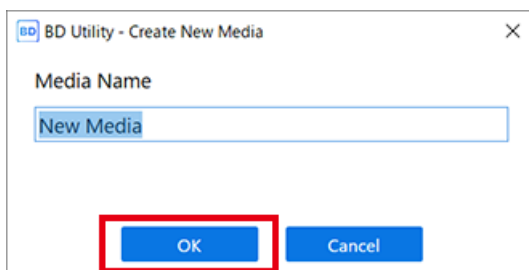

8. Enter a name that you will recognize as being for the nozzle drop-out test, and then click [OK]. Previously registered media names cannot be used.



9. Select [Opaque] on the [Object Type] window, and then click [OK].

10. Click [Change] next to [Flat Table Height], and then set the height of the nozzle drop-out test paper.

- (1) Click  or  on the right side of the window to align the nozzle drop-out test paper on the flat table with the forward-back position of the head gap sensor.

## MEMO

You can select 0.1 mm (0.004 in.), 1 mm (0.04 in.), 10 mm (0.39 in.), or 50 mm (1.97 in.) as the single-click moving distance.

- (2) Click  on the left side of the window to move the nozzle drop-out test paper on the flat table closer to the head gap sensor.

Move the highest printing position of the object up to a position (a) a few mm away from the head gap sensor without coming into contact with the head gap sensor.

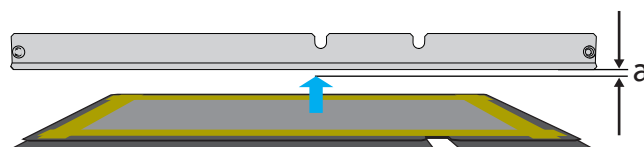

- (3) Click [Automatic Setup].  
The flat table moves and the head gap sensor detects the nozzle drop-out test paper.
- (4) Click [OK].





11. Click [Change] next to [Print Origin] and [Printing Area], and set range of the nozzle drop-out test. The printing size for the nozzle drop-out test is approximately 90 mm × 51 mm (3.54 in. × 2.01 in.) (landscape).

## MEMO

When the [Printing Area] setting is finished, the print-head carriage returns to its original position after it has been left in the same position for approximately 3 minutes to prevent the print heads from drying out. Perform the procedure again.

- (1) Select [Pointer] for [Position Specification].

The print-head carriage moves, and then the pointer on the right side of the print-head carriage illuminates the lower right (S: 0 mm [0 in.], F: 0 mm [0 in.]) of the maximum printing area.

- (2) Click , , , or , and then move the pointer to specify the print origin (lower right of the printing area).

The print-head carriage moves in the left-right direction and the flat table moves in the forward-backward direction. The position that the pointer illuminates serves as the print origin.

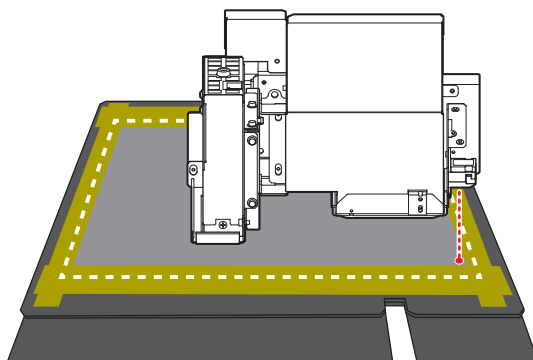

- (3) Click [OK].

Returns to the [Flat Table Height], [Print Origin], and [Printing Area] settings window.

## MEMO

## About [Printing Area]

Since the [Print Origin] is unchanged and the [Origin Relative] is specified here, the upper left of the printing area is automatically set to the maximum position (S: 210 mm [8.26 in.], F: 148 mm [5.82 in.]).

12. Click [OK].

[Setup in progress.] is displayed. When setup is completed, you are returned to the home screen, and the registered object name, and the set [Flat Table Height], [Print Origin], and [Printing Area] are displayed.

The nozzle drop-out test paper is now registered and set up.

## MEMO

If you are printing continuously on the same media, such as when performing a nozzle drop-out test followed by cleaning and then another nozzle drop-out test, click , and then change the print origin registered in [List of Media Settings].

### RELATED LINKS

- [P. 27 Nozzle Drop-out Test](#)
- [P. 64 Performing a Nozzle Drop-out Test](#)

## Starting/Exiting Utility

### Starting Utility

#### Procedure

1. Click the Roland DG Connect Hub icon in the notification area.

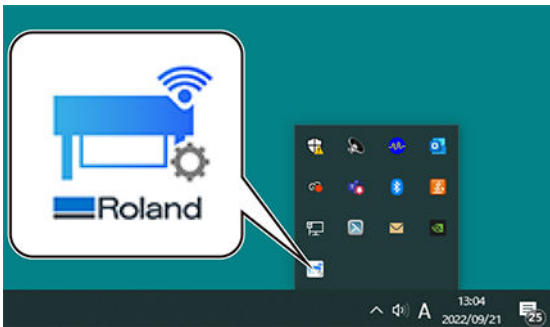

2. Click the machine to use.

The applications that can be used with the selected machine are displayed on the right side of the screen.

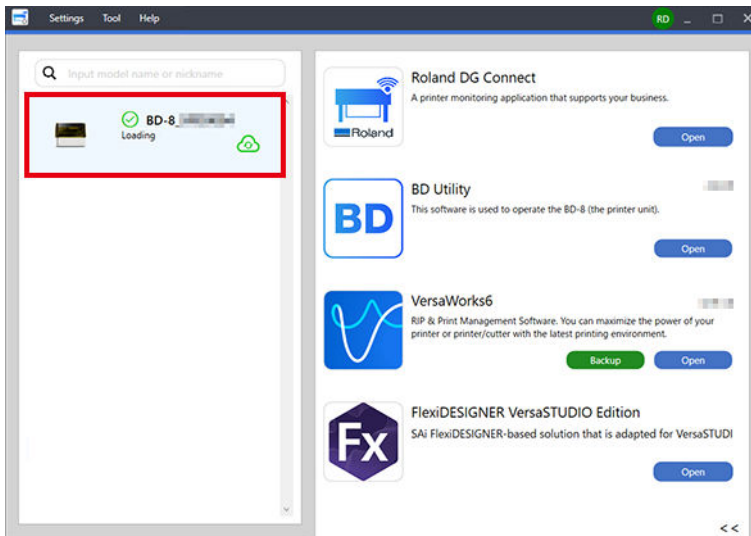

3. Click [Open] for Utility.

Utility starts, and then the following window is displayed.



---

## Exiting Utility

---

### Procedure

1. Click  in the upper-right corner of the Utility window.
2. In the confirmation window, click [OK].  
Exit Utility.

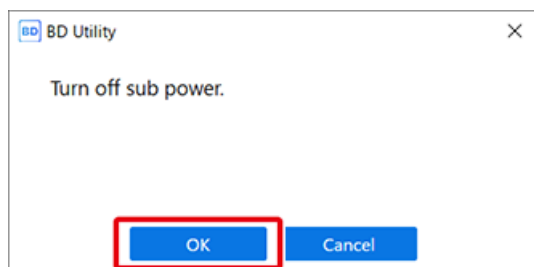

## Utility Home Screen

Utility is software that displays the printer status, configures the printer settings, and performs printer operations.

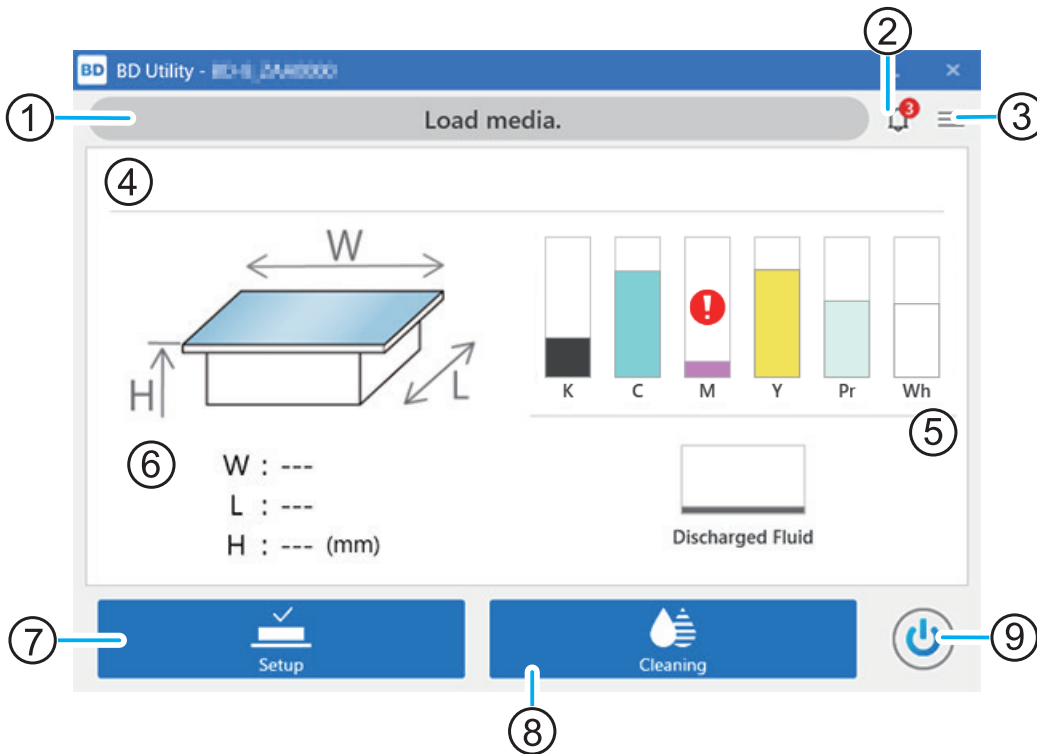

No.	Name	Details
①	Status bar	Displays the printer status and indicates the next operation.
②	Notifications	Displays important information. When there are notifications, their number is displayed on the icon.
③	Menu	Use this to configure printer settings.
④	Media information	Displays the object information. Once the object is set up*1, the name of the object is displayed.
⑤	Amount of ink remaining and amount of discharged fluid	Displays the amount of ink remaining in each ink cartridge and the amount of discharged fluid in the drain pack. If it is time to replace a color,  is displayed next to the corresponding ink cartridge. Click this icon to display the detailed information for the ink.
⑥	Printing area and height	Once the object is set up, the set printing area (W: width, L: length, H: height*2) is displayed.
⑦	[Setup]/[Cancel Setup]	Starts/cancels setting up the object to be printed on.
⑧	[Cleaning]	Displays the menu related to the nozzle drop-out test and cleaning.
⑨	Sub power	Operate the machine's sub power supply with Utility.

\*1 Setup refers to placing the object on the flat table, setting the printing area and printing height, and making the object ready for printing.

---

\*2 You can select the flat table position from [Flat Table Height] (H) and [Object Thickness] (T).



## Menu List

Click  to display the [Menu] window.

### [List of Media Settings]

#### MEMO

In Utility, the window that lists the setting values of objects is called the [List of Media Settings].

This window displays the setting information of the object that has been set up. This window is not displayed if the object has not been set up.

You can check and change\*<sup>1</sup> the setting values when registering the objects. To the right of [Print Origin] is an item to be set when changing the [Origin Relative]. It is not a setting for this media.

For more information, refer to [Object \(Media\) Registration Items](#).

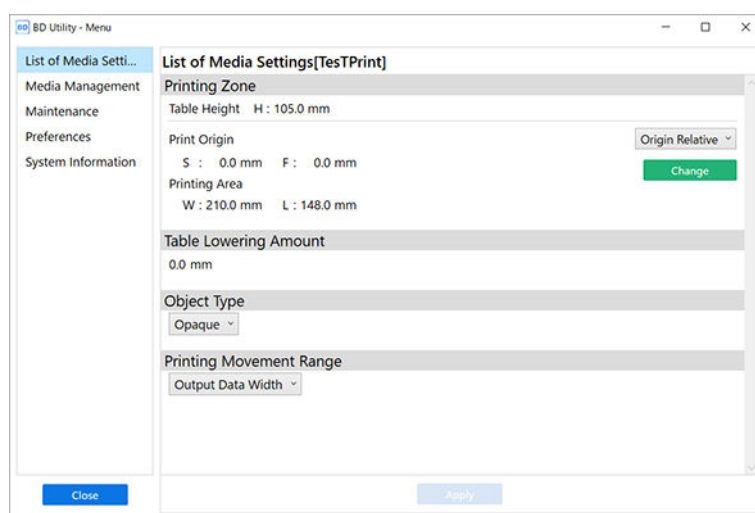

#### [Printing Zone]

##### [Flat Table Height]

The height direction position to be printed is displayed.

##### [Print Origin]

The point that will serve as the base for printing position is displayed as the distance from the lower right reference point (S: 0 mm [0 in.], F: 0 mm [0 in.]) on the flat table.

##### [Printing Area]

The area to print that uses the print origin as the base is displayed in the distance (mm) in the W:S direction and then in the distance (mm) in the L:F direction.

#### [Flat Table Lowering Amount]

The setting values for how far down from the standard flat table position to print are displayed.

#### [Object Type]

[Transparent] or [Opaque] is displayed.

#### [Printing Movement Range]

The operation width of the print-head carriage when printing is displayed as either [Output Data Width], [Media Width], or [Full Width].

\*1 You cannot change [Flat Table Height] and [Flat Table Lowering Amount].

**MEMO**

[Media Width] will be the width set for the printing area.



**RELATED LINKS**

- [P. 126 Setting a Longer Distance between the Object and the Print Heads](#)
- [P. 120 Minimizing Print-head Carriage Movement](#)

## [Media Management]

### MEMO

In Utility, the window for managing objects is referred to as [Media Management], and objects are referred to as "media."

You can save up to 50 objects. The  icon indicates a normal object and the  icon indicates an object for the rotation shaft unit.

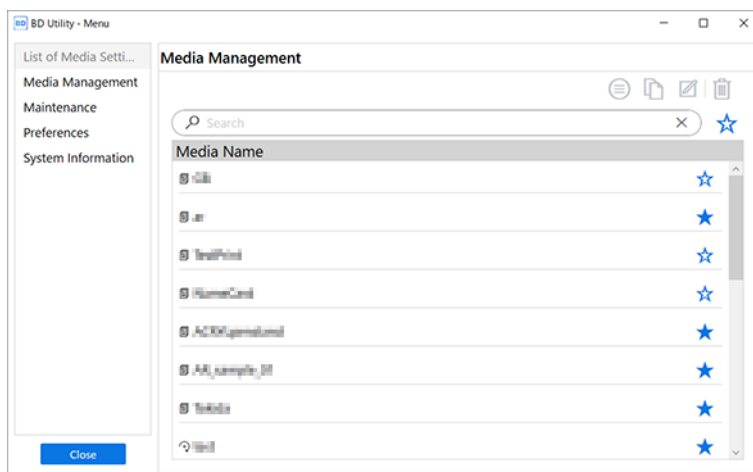

You can select registered media to review, duplicate, delete, or take other action for setting details.

### : [Display Media Settings]

Displays the details set for the registered media.

### : [Duplicate Media]

Duplicate the setting details of the registered media and then register it as separate media.

### : [Change Media Name]



Changes the name of the registered media.

### : [Delete Media]

Deletes the registered media that is selected.

### Search Function and Favorites Function

You can search for a media name with the search box. Furthermore, you can set commonly used media as favorites and display only these favorites. You can also search while favorites are displayed.

1. Click  next to a media name to change this icon to .
2. Click  next to the search box.

The icon changes to , and the list of media set as favorites appears.

Click  again to display the list of all media.

## [Maintenance]

Use this to replace consumable parts and perform other maintenance.

Click  to view a related video. We recommend that you view this video to understand the overall flow of work.

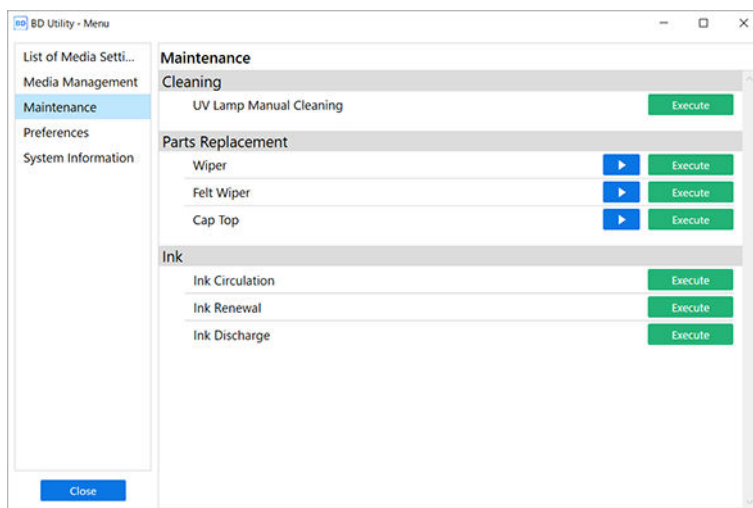

### [Cleaning]

#### UV Lamp Manual Cleaning

Click [Execute] to switch to the [UV Lamp Manual Cleaning] execution screen. Follow the instructions shown on the screen to clean the UV lamp.

### [Parts Replacement]

#### Wiper

Click [Execute] to switch to [Wiper Replacement] execution screen. Follow the on-screen instructions to replace the wiper.

#### Felt Wiper

Click [Execute] to switch to [Felt Wiper Replacement] execution screen. Follow the on-screen instructions to replace the felt wiper.

#### Cap Top

Click [Execute] to switch to [Cap Top Replacement] execution screen. Follow the on-screen instructions to replace the cap top.

### Ink

#### Ink Circulation

Circulates ink to prevent uneven color issues with white ink. Click [Execute] to start [Ink Circulation].

#### Ink Renewal

When ink circulation does not correct the unevenness of the white ink color, replace (refresh) the white ink. Click [Execute] to start [Ink Renewal].

#### [Ink Discharge]

Performs in advance the ink discharge which is otherwise performed regularly. For normal use, it is not necessary for the user to execute this. Click [Execute] to start [Ink Discharge].

### RELATED LINKS

- [P. 174 Cleaning the UV-LED devices](#)
- [P. 192 Replacing the Wiper](#)
- [P. 194 Replacing the Felt Wiper](#)

- [P. 196 Replacing the Cap Top](#)
- [P. 182 Ink Renewal](#)
- [P. 183 Ink Discharge](#)

## [Preferences]

Change the operation settings of the machine to match the usage environment.

Click  to view a related video. We recommend that you view this video to understand the overall flow of work.

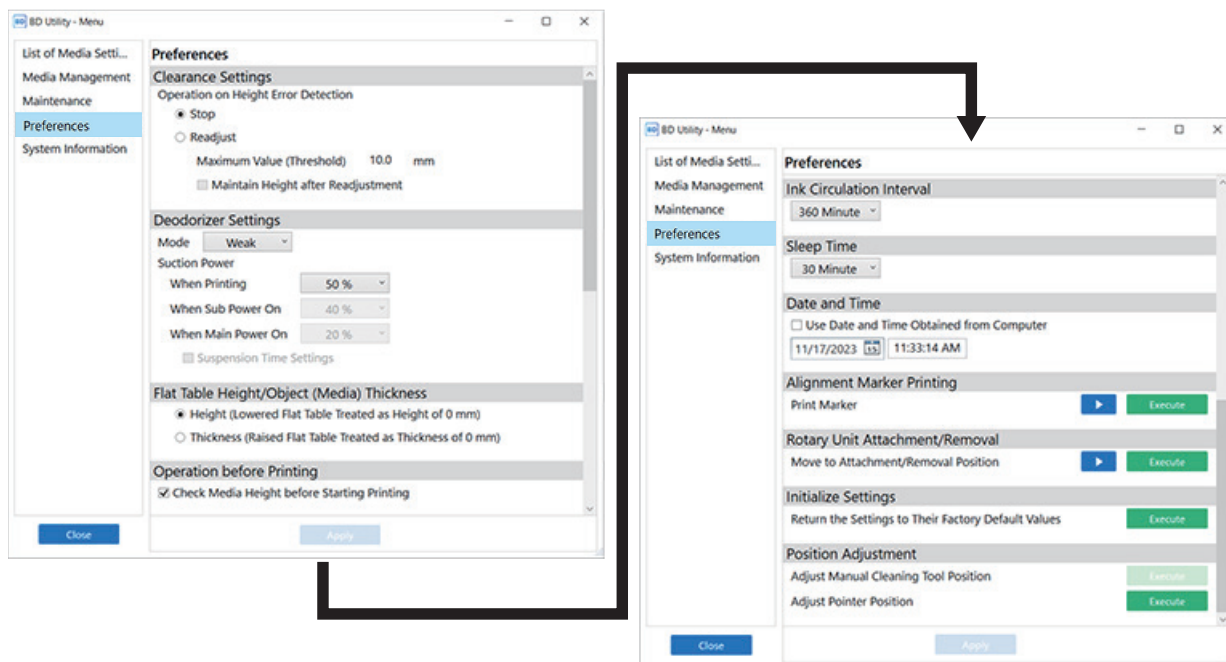

### [Clearance Settings]

Sets the action to be taken when a height error occurs during printing. Select from **[Stop]** or **[Readjust]**. If **[Readjust]** was selected, set the amount to lower the flat table in **[Maximum Value (Threshold)]**.

### [Deodorizer Settings]

Changes the deodorizer mode. Select from **[Strong]**, **[Medium]**, **[Weak]**, or **[Off]**. You can also set the suction power for each mode.

### [Flat Table Height/Object (Media) Thickness]

Changes the height direction reference. Select from **[Height (Lowered Flat Table Treated as Height of 0)]** or **[Thickness (Raised Flat Table Treated as Thickness of 0)]**.

### [Operation before Printing]

Set whether to check the height of the object after the object is set up and before printing starts.

### [Ink Circulation Interval]

Sets the frequency of white ink circulation to prevent uneven color issues. Select from 30 to 360 minutes in increments of 30 minutes.

### [Sleep Time]

Sets the time until sleep mode (the state in which the power-saving features operate) activates. Select from 15 to 120 minutes in increments of 15 minutes.

### [Date and Time]

Changes the date and time printed on the nozzle drop-out test.

### [Alignment Marker Printing]

Prints alignment markers over the flat table. Set up tape for alignment markers or similar to enable [Execute].

### [Rotary Unit Attachment/Removal]

This is used when attaching/removing the rotary axis unit.

### [Initialize Settings]

Clicking [Execute] returns [List of Media Settings], [Preferences], and [Network] to their factory default values. However, [Position Adjustment] will not be initialized.

### [Position Adjustment]

- **[Adjust Manual Cleaning Tool Position]**  
Adjusts the position when the manual cleaning tool is changed.  
[Execute] is not enabled when the object is set up. Cancel the setup, and then remove the object.
- **[Adjust Pointer Position]**  
Adjusts the misalignment between the printing area and the pointer position.  
Set up media for pointer position adjustment to enable [Execute].

#### RELATED LINKS

- [P. 122 Flat Table Height Setting](#)
- [P. 132 Setting the Deodorizer Mode](#)
- [P. 129 Setting the \[Ink Circulation\] Interval](#)
- [P. 135 Adjusting the Date and Time](#)
- [P. 77 Alignment Marker Printing](#)
- [P. 131 Removing/Attaching Optional Items \(OA-RA-8\)](#)
- [P. 137 Setting the Base Position of the Manual Cleaning Tool](#)

## [System Information]

You can use this window to check the machine and network information.

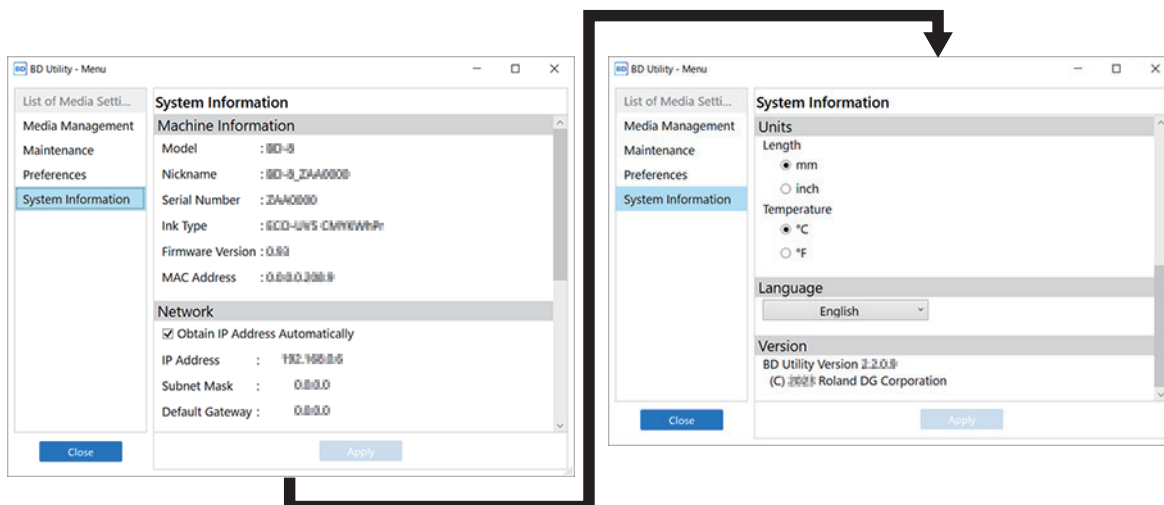

### [Machine Information]

You can check the following information:

- [Model]
- [Nickname]
- [Serial Number]
- [Ink Type]
- [Firmware Version]
- [MAC Address]

### [Network]

You can check and edit the network settings of the connected machine.

Turn on [Obtain IP Address Automatically] to automatically obtain the machine's IP address, subnet mask, and default gateway.

- [IP Address]
- [Subnet Mask]
- [Default Gateway]

### [Units]

Sets the [Length] and [Temperature].

### [Language]

Sets the display language.

### [Version]

Displays the Utility version information.



# Daily Overall Flow

This section explains the workflow of daily operations.

Performing appropriate maintenance at the correct times can help prevent malfunction as well as bring out the full potential of this machine.

## Workflow

This section provides an example workflow for a store that prints immediately after an order is placed.

### Before Opening

1. Mix the white ink. [Maintenance of Ink Cartridges\(P. 163\)](#)
2. Turn on the sub power of the main unit. [Turn on the sub power\(P. 51\)](#)
3. Start Utility. [Starting Utility\(P. 35\)](#)
4. Check the notifications.  
Perform maintenance according to the notifications. [Notifications\(P. 228\)](#)
5. Perform a nozzle drop-out test. [Step 1: Performing a Nozzle Drop-out Test\(P. 64\)](#)
6. Take action as appropriate for the test pattern results.
  - Good: Finish machine standby
  - Bad: Implement normal cleaning [Step 2: Performing Normal Cleaning\(P. 66\)](#)

### Business Hours

Print when the order for printing is placed. [Step 4: Perform Printing\(P. 76\)](#)

If a message is displayed in Utility, take action as indicated in the window. The following are messages that frequently appear in notifications.

- [The time for ink mixing has arrived.]  
This message prompts the user to mix the white ink cartridge. [Maintenance of Ink Cartridges\(P. 163\)](#)
- [The time for manual cleaning has arrived.]  
This message appears when it is time to clean using the manual cleaning tool. [Manual Cleaning Method\(P. 168\)](#)

There are several other maintenance notifications. Be sure to always check notifications in Utility: .

### After Closing

1. Check that there are no maintenance notifications. [Notifications\(P. 228\)](#)
2. Clean the machine. [Cleaning the Machine\(P. 164\)](#)
3. Switch off the sub power. [Turn off the sub power\(P. 53\)](#)
4. Exit Utility. [Exiting Utility\(P. 37\)](#)

# Basic Operations

---

Power Supply Operations .....	50
Turn on the sub power .....	51
Turn off the sub power .....	53
Sleep Mode (Power-saving Feature) .....	54
Turning the Power Off During Emergencies .....	55
Opening/Closing the Cover .....	56
Opening/Closing the Front Cover .....	56
Attaching/Removing the Maintenance Cover .....	58
Pausing and Canceling Printing .....	59
Pausing and Resuming Printing .....	59
Canceling Printing .....	60

# Power Supply Operations

Always keep the main power switched on. Turn the sub power on before use and turn it off after use.

*Main Power On*

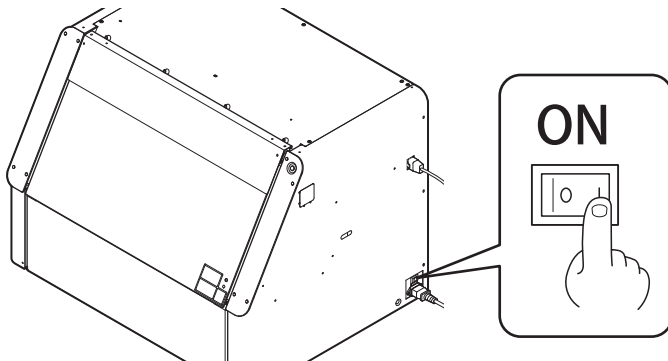

After the sub power is turned on, the unit will enter sleep mode after a certain period of inactivity. See the following for information on how to recover from sleep mode.

[P. 54 Sleep Mode \(Power-saving Feature\)](#)

## IMPORTANT

- **Always keep the main power switched on.**  
Never switch off the main power. Leaving the main power enables automatic maintenance to be carried out periodically. If the automatic maintenance is not carried out, it may result in the breakdown of this machine, such as the breakdown of the print heads.
- **Never switch off the main power or unplug the power cord suddenly while operation is in progress.**  
Switching off the main power or unplugging the power cord suddenly while operation is in progress may damage the print heads or otherwise cause the machine to fail.

## MEMO

**What about when turning the main power off?**

When it is necessary to turn off the main power, such as during transfer, be sure to turn off the sub power before turning off the main power. Then promptly turn on the main power.

## Turn on the sub power

You can switch the sub power on with a button on the machine or an icon in Utility.

### Turning On the Sub Power with the Button on the Machine

#### Procedure

1. Ensure that the maintenance cover and front cover are closed and that the main power is on.

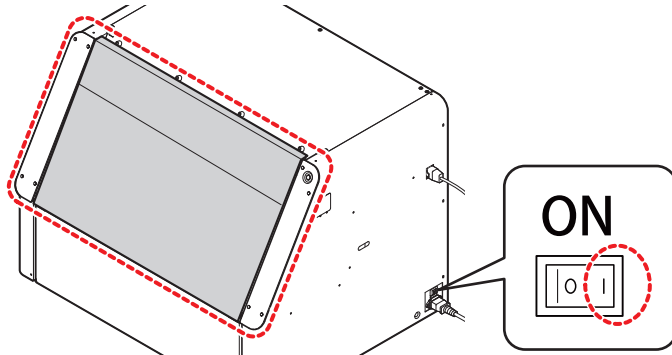

2. Press the sub power button.

The sub power is switched on. When the sub power button changes from flashing blue to steady blue, startup is finished.

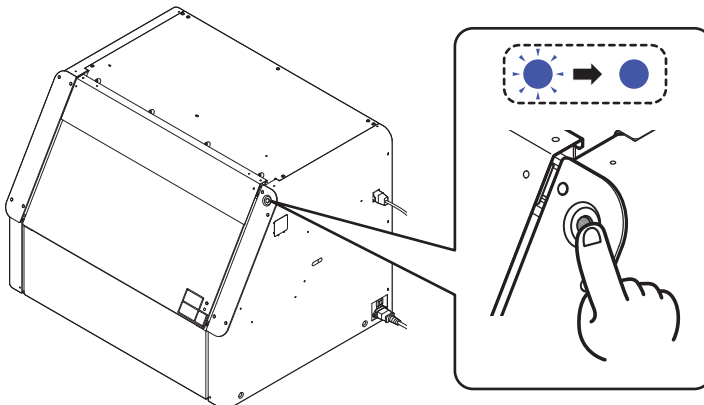

#### MEMO

If the main power is off, turn the main power on to start firmware initialization. There will be no response when pressing the sub power button until initialization is complete. In this case, wait some time before pressing the sub power button.

## Turning On the Sub Power of the Machine with Utility

### Procedure

1. Ensure that the maintenance cover and front cover are closed and that the main power is on.

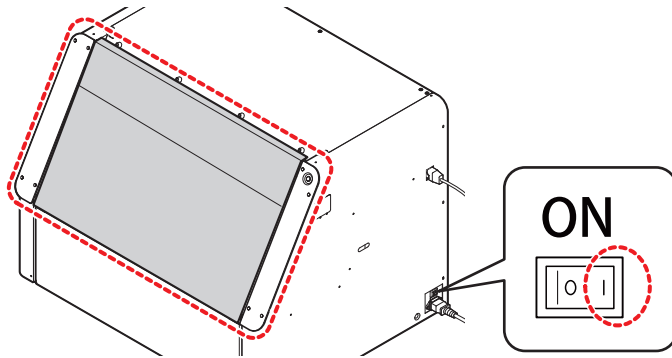

2. Start Utility.

[P. 35 Starting Utility](#)

3. Click .

The sub power is switched on. When the machine's sub power is turned on, the icon changes to



#### MEMO

If the main power is off, turn the main power on to start firmware initialization. There will be no response when  is pressed until initialization is complete. In this case, wait some time before pressing the sub power button.

Once the sub power is turned on, the Utility home screen is displayed.

## Turn off the sub power

You can switch the sub power off with a button on the machine and an icon in the Utility window.

### Turning Off the Sub Power with the Button on the Machine

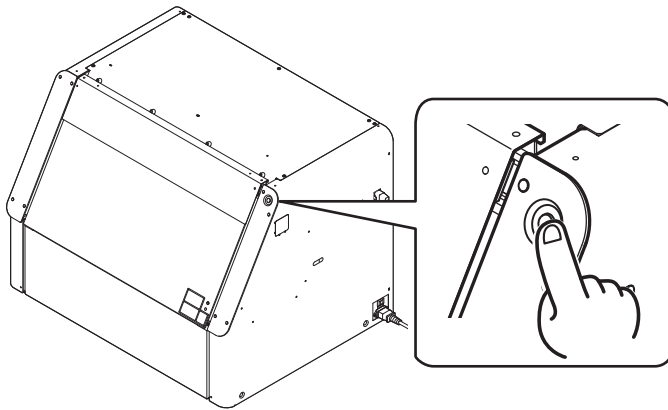

#### Procedure

1. When you're finished working, hold down the sub power button for 1 second or longer. When the sub power button darkens, the sub power is switched off.



### Turning Off the Sub Power of the Machine with Utility

#### Procedure

1. When the work is finished, click  on Utility.
2. When the [Turn off sub power.] window appears, click [OK]. After some time, [The sub power is off.] is displayed on the Utility status bar, and the sub power icon changes to .

## Sleep Mode (Power-saving Feature)

This machine is provided with a power-saving feature that switches to a low-power "sleep mode" when a fixed interval passes with no operation.

When the machine is in the sleep mode, the sub power button flashes in blue slowly. Recover from the sleep mode by performing one of the following operations.

- Press the sub power button.
- Open the front cover.
- Click [**Recover**] in Utility.
- Send the print data from the computer (with the object set up).

### MEMO

- Default setting: [30 min]

### RELATED LINKS

- [P. 134 Setting the Activation Interval for Sleep Mode \(Power-saving Feature\)](#)

## Turning the Power Off During Emergencies

The print-head carriage and flat table may operate automatically during setup, maintenance, or other operations even when the front cover of the machine is open.

If the print-head carriage or flat table starts to move unexpectedly and your hand or an object is about to be caught in it, press the emergency stop button to stop the printer operation.

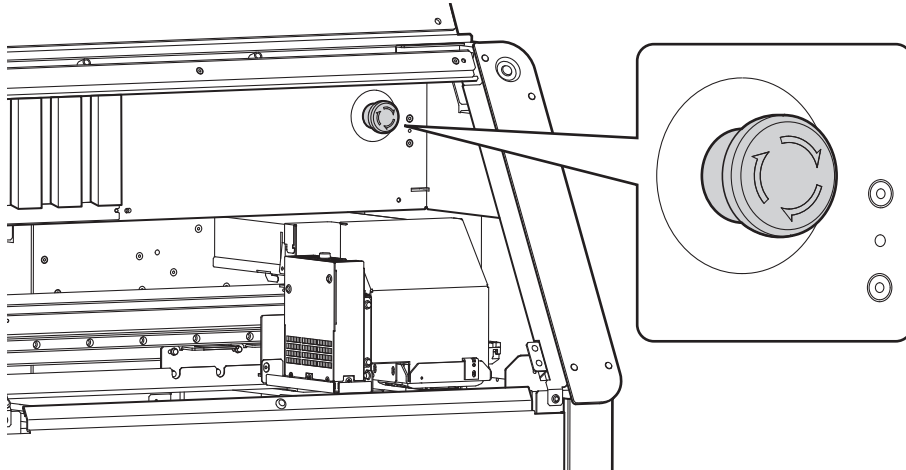

When the emergency stop button is activated, you will be notified with **[Emergency Stop Error]** in Utility.

If the print heads are stopped in a position where they are separated from the print head caps, they should be restored to their original position within 10 minutes to prevent them from drying out.

See [\[Emergency Stop Error\]](#) for more information on how to restore the print heads to their original position.



# Opening/Closing the Cover

## Opening/Closing the Front Cover

Most operations, such as setting up objects, removing and attaching ink cartridges, and maintenance, are performed with the front cover open. To reduce odors and prevent the print heads from drying out, keep the front cover closed except when opening it is necessary.

### Procedure

1. Make sure there are no foreign objects on the top of the front cover.

#### CAUTION

When opening the front cover, do not place hands or objects in the area shown in the figure.

Doing so may result in injury from pinching fingers or damage to the front cover.

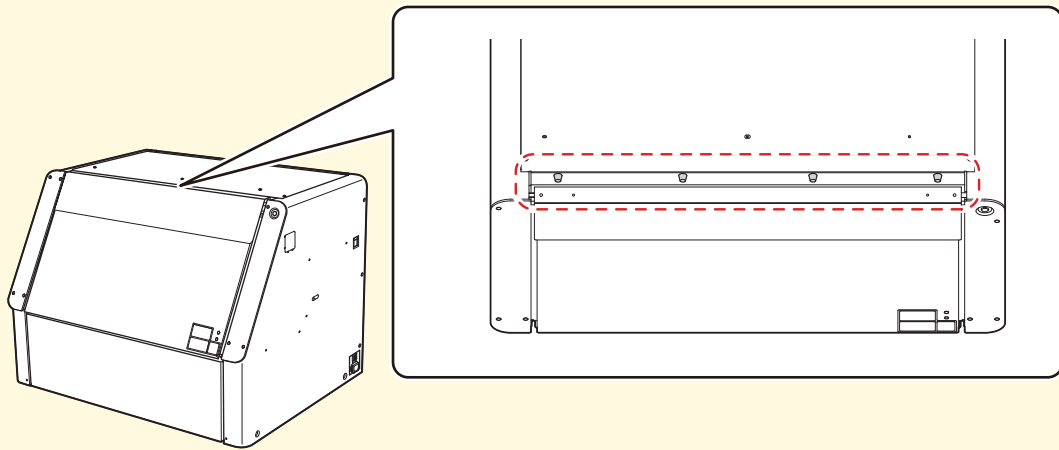

2. Hold the position shown in the figure and open the front cover.

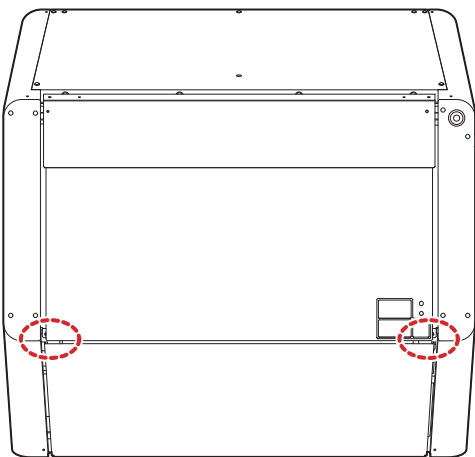

3. Perform the necessary work.
4. Check the following before closing the front cover.
  - A: There are no foreign objects between the front cover and the machine

- B: The maintenance cover is installed

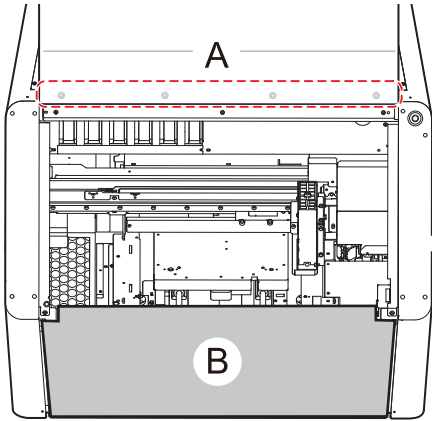

5. Close the front cover.

## Attaching/Removing the Maintenance Cover

Work performed with the maintenance cover removed includes replacing discharged fluid packs, removing and installing optional items and stored fixtures, and similar tasks. Keep the maintenance cover securely attached except when necessary.

### Procedure

1. Open the front cover.

P. 56 Opening/Closing the Front Cover

2. Remove the maintenance cover according to the following procedure.

- (1) Hold the underside of the maintenance cover, and pull it approximately 30 mm (1.18 in.) towards you.
- (2) Lift the maintenance cover up to remove it.

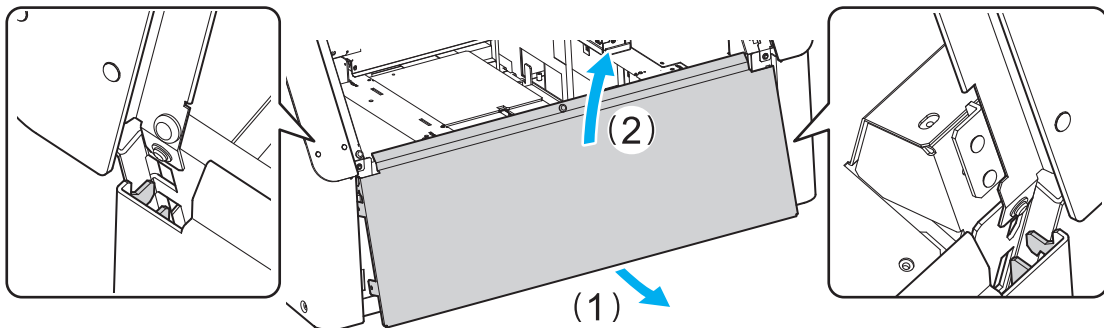

3. Perform the necessary work.

4. Attach the maintenance cover according to the following procedure.

- (1) Insert the hooks (B) on the maintenance cover into the grooves on the left and right (A).
- (2) Press the maintenance cover against the machine.

Make sure the maintenance cover is secured by the magnets (C).

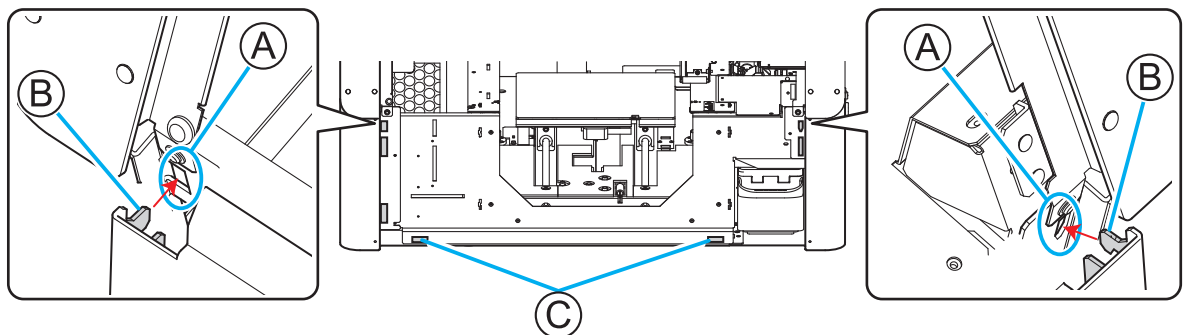

5. Close the front cover.

# Pausing and Canceling Printing

Printing can be paused or stopped midway through printing, but restarting after a pause will affect print quality.

## Pausing and Resuming Printing

### IMPORTANT

We do not recommend resuming printing after pausing, as it will affect the print quality, such as by causing horizontal stripes to appear at the position where printing was paused.

### Procedure

1. Click [Pause] on the Utility home screen while printing.  
Printing pauses.

### MEMO

You cannot operate the home screen while the menu screen is displayed. Close the menu screen.

2. Click [Resume].  
Printing resumes.

## Canceling Printing

### Canceling Printing with Utility

#### Procedure

1. Click [Pause] on the Utility home screen while printing.  
Printing pauses.

#### MEMO

You cannot operate the home screen while the menu screen is displayed. Close the menu screen.

2. Click [Cancel Output].
3. In the confirmation window, click [OK].  
Printing is canceled.

### Canceling Printing from the Printer

#### Procedure

1. Hold down the sub power button for 1 second or longer during printing.  
Printing is canceled, and the sub power of the machine switches off automatically. You cannot resume output from the point it was canceled.

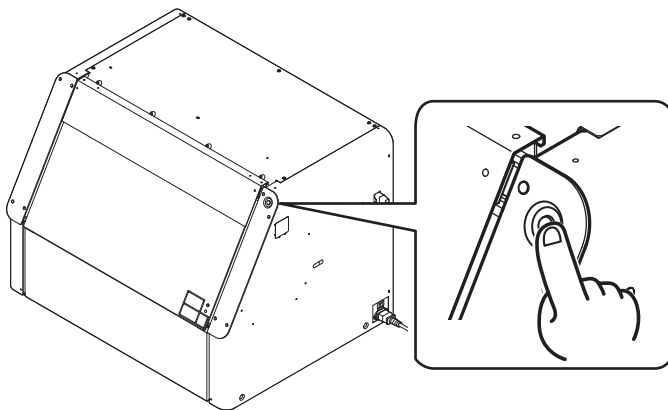

2. Press the sub power button to turn the sub power on.

# Printing method

# Preparations for Printing

---

Computer Preparations .....	63
Preparing Utility .....	63
Preparing the Machine .....	64
Step 1: Performing a Nozzle Drop-out Test .....	64
Step 2: Performing Normal Cleaning .....	66

# Computer Preparations

## Preparing Utility

Start the computer and configure Utility so that you can use it.

### Procedure

1. Start the computer on which Utility is installed.

2. Start Utility.

[P. 35 Starting Utility](#)

#### MEMO

Set the mode of the deodorizer as appropriate for how frequently you print and for the surrounding environment. We recommend checking the mode of the deodorizer at this point.

[P. 26 Deodorizer](#)

### RELATED LINKS

- [P. 24 Composition and Role of Software Used in the Machine](#)



# Preparing the Machine

## Step 1: Performing a Nozzle Drop-out Test

Perform a nozzle drop-out test (print a test pattern) and confirm the test pattern before starting printing. If an error occurs, clean the print heads (normal cleaning). After that, perform the nozzle drop-out test again.

### MEMO

Use the following link to view a reference video for this procedure. We recommend that you view this video to understand the overall flow of work.

<https://youtu.be/qQr12nD06Qw>

### Procedure

1. Set up the nozzle drop-out test paper.
2. On the Utility home screen, click  [Cleaning].
3. Click [Output] under [Nozzle Drop-out Test].  
Printing of the test pattern starts.

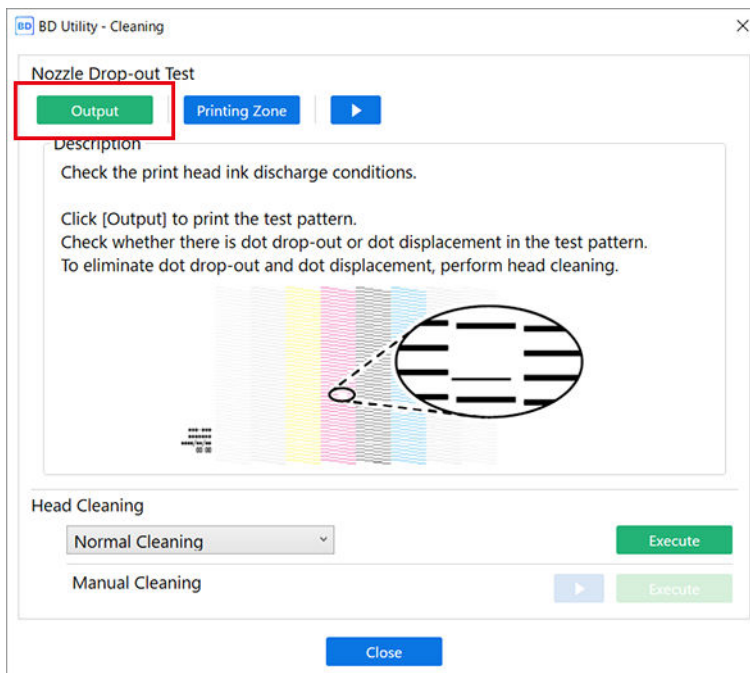

4. Check whether there is dot drop-out or dot displacement in the test pattern.  
Missing sections in the test pattern indicate "dot drop-out," while a collapsed or sloping test pattern indicates "dot displacement." If the test pattern is difficult to see, open the front cover or remove the nozzle drop-out test paper, and then change the angle to check the pattern.
  - If no dot drop-out or dot displacement occurs: Proceed to the next step.
  - If dot drop-out or dot displacement occurs: Proceed to [Step 2: Performing Normal Cleaning](#).

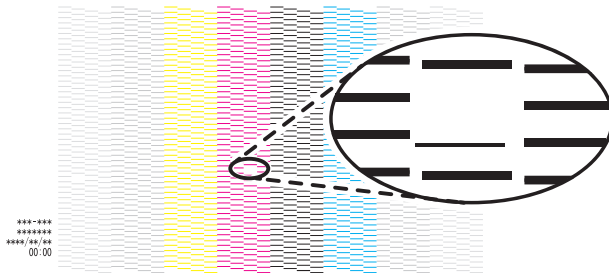

5. Remove the nozzle drop-out test paper, and then close the front cover.

6. Click [Close] to return to the original screen.

#### RELATED LINKS

- [P. 31 Registering and Setting Up the Nozzle Drop-out Test Paper](#)
- [P. 27 Nozzle Drop-out Test](#)

## Step 2: Performing Normal Cleaning

If dot drop-out or dot displacement was present in step 1, perform normal cleaning.

### Procedure

1. Select [Normal Cleaning] under [Head Cleaning], and then click [Execute].

[Cleaning in progress.] and an estimate for the remaining cleaning time are displayed on the Utility home screen.

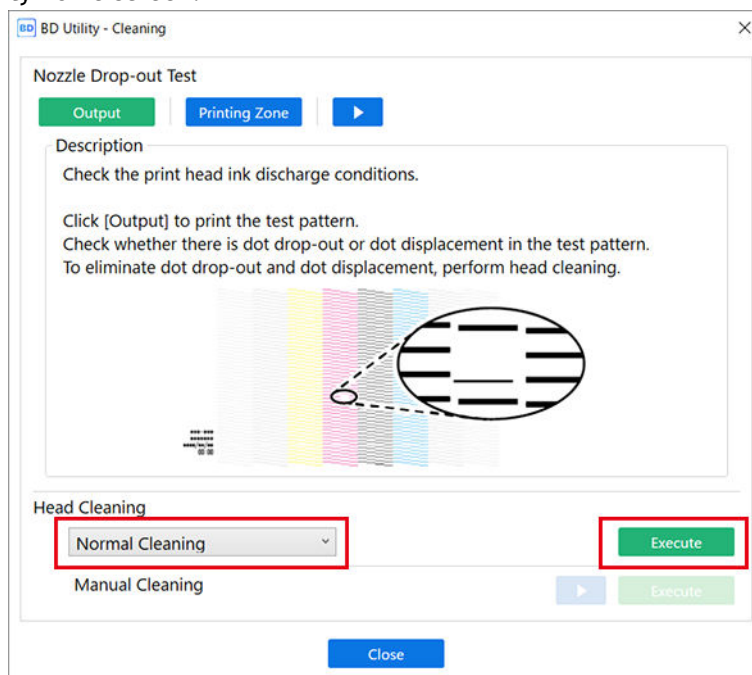

2. Set up the nozzle drop-out test paper again.
  - If you have removed the nozzle drop-out test paper and checked the test pattern, set up the printer again.
  - If you have checked the test pattern without removing the nozzle drop-out test paper, click , and then change the [Print Origin] you have specified with [List of Media Settings].
3. Click [Output] under [Nozzle Drop-out Test].
4. When printing is complete, open the front cover.
5. Check whether there is dot drop-out or dot displacement in the test pattern. Missing blocks indicate dot drop-out. Collapsed or inclined blocks indicate dot displacement.

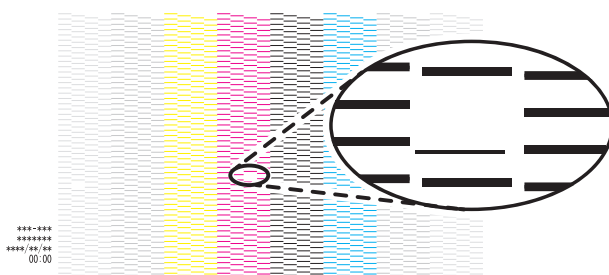

**MEMO**

- If the problem persists, try performing normal cleaning again.
- If problems such as dot drop-out and dot displacement persist even after you have performed normal cleaning several times, use a different cleaning method.

If no dot drop-out or dot displacement occurs, preparations for output are finished.

6. Close the front cover.
7. Click [Close] to return to the original screen.

**RELATED LINKS**

- [P. 31 Registering and Setting Up the Nozzle Drop-out Test Paper](#)
- [P. 160 Action Taken When Dot Drop-out or Dot Displacement Occur](#)

# Starting Printing

---

When Determining the Printing Position Manually.....	69
Step 1: Creating Printing Data.....	69
Step 2: Placing the Object.....	70
Step 3: Setting Up the Object.....	72
Step 4: Perform Printing.....	76
Determining the Printing Position Using Captured Images .....	77
Step 1: Alignment Marker Printing.....	77
Step 2: Placing and Imaging the Object .....	79
Step 3: Setting Up the Object.....	81
Step 4: Creating Data while Checking the Position .....	84
Step 5: Perform Printing.....	86
Print Parameters (FlexiDESIGNER) .....	87

# When Determining the Printing Position Manually

## MEMO

Use the following link to view a reference video for this procedure. We recommend that you view this video to understand the overall flow of work.

<https://youtu.be/XtlasiJZ5sM>

## Step 1: Creating Printing Data

Decide on the object and the area to be printed to create the print data.

### Procedure

1. Decide on the object and the area to be printed.
2. Follow the procedure below to start FlexiDESIGNER.
  - (1) Start Roland DG Connect Hub.
    - Windows 11
      - i. Click [Start]>[All apps].
      - ii. From the list of apps (programs), click [Roland DG Corporation]>[Roland DG Connect Hub].
    - Windows 10
      - i. Click [Start].
      - ii. From the list of apps (programs), click [Roland DG Corporation]>[Roland DG Connect Hub].
  - (2) Click the machine (BD-8) to use.
  - (3) Click [Open] for FlexiDESIGNER.

## MEMO

When print data is created using commercially-available application software, the process from data creation to printing differs.

3. Create and save the print data.  
See "Introduction to FlexiDESIGNER."

## RELATED LINKS

- [Introduction to FlexiDESIGNER](#)
- [P. 226 Printing Using Commercially-available Application Software](#)

## Step 2: Placing the Object

Place the object on the flat table.

### Procedure

1. Press the sub power button.
2. Open the front cover.

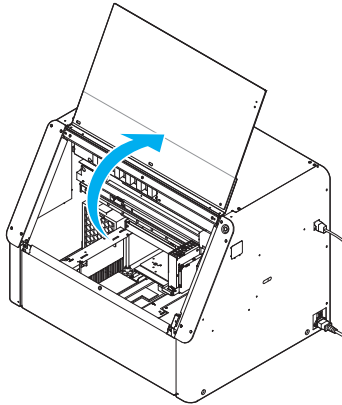

3. Make sure there is no debris or other foreign objects adhered to the flat table.
4. Secure the object to be printed on in place on the flat table.
  - **Recommendations**  
Secure the object with an adhesive sheet.

#### MEMO

The size of the included adhesive sheet is A5 (210 mm × 148 mm (8.27 in. × 5.83 in.)). It is preferable to align the adhesive sheet with the white border of the maximum printing area.

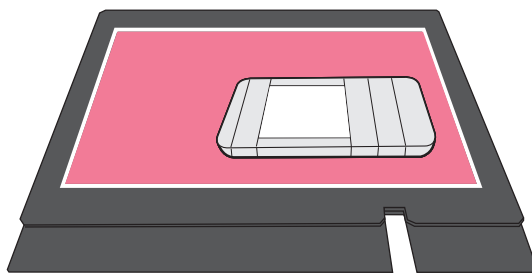

- **Unstable or Otherwise Unwieldy Objects**  
Use masking tape to secure paper with creases from folding or paper that tends to curl up due to having been rolled up. If the shape of the object makes it difficult to secure, use a jig.

Masking tape

Jig

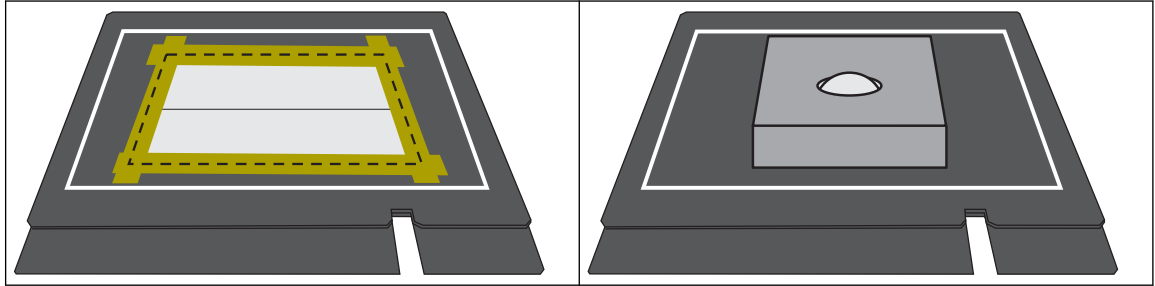

When the adhesive sheet loses its adhesive strength, rinsing it clean with water will improve it. If the adhesive sheet does not regain its adhesive strength even after rinsing it clean with water, replace the adhesive sheet. For information about purchasing adhesive sheets, contact your authorized dealer or visit our website (<https://www.rolanddg.com/>).

**IMPORTANT**

**Protect areas outside of the printing area of thick objects.**

Fine particles of ink that are scattered on areas other than the printing area are called "ink mist." Once this ink mist adheres to the object, it becomes difficult to remove. Cover areas outside the printing area and the sides of objects with masking tape (A) or use a jig (B).

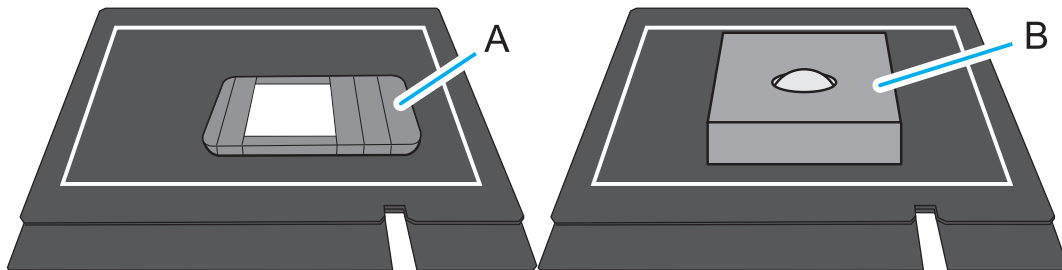

**5.** If necessary, perform the following operations.

- Use a static removal brush or anti-static cloth to eliminate static electricity from the object.
- Degrease the printing area of the object using anhydrous ethanol or isopropyl alcohol.

**6.** Close the front cover.

**RELATED LINKS**

- [P. 21 Considering a Jig](#)



## Step 3: Setting Up the Object

Place the object, and then make it ready for printing.

### IMPORTANT

You can keep the front cover open when you set the height of the flat table, the print origin, or other settings for a closer view as you work.  
However, clicking [OK] with these settings configured may cause the print-head carriage or flat table to start moving. Therefore, when the front cover is open, be careful not to touch any moving parts as you work.

### Procedure

1. On the Utility home screen, click  [Setup].
2. Register/select the object.

### MEMO

In Utility, "media" is used on the window used to register/manage objects.

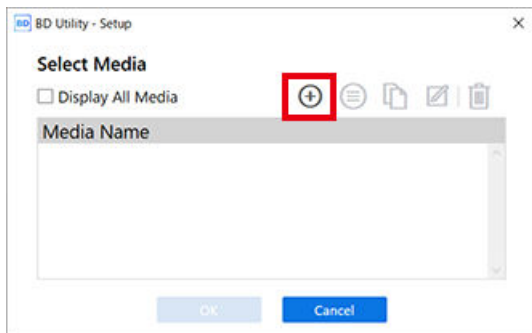

- When printing on an object for the first time
  - a. Click .

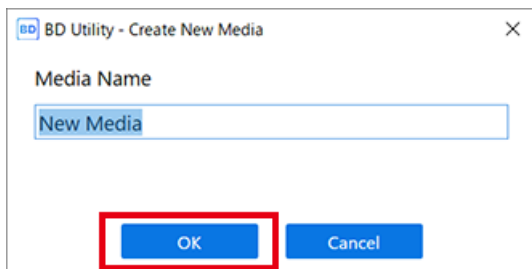

- b. Enter the name of the new object, and then click [OK].  
Previously registered media names cannot be used. Enter a new media name.





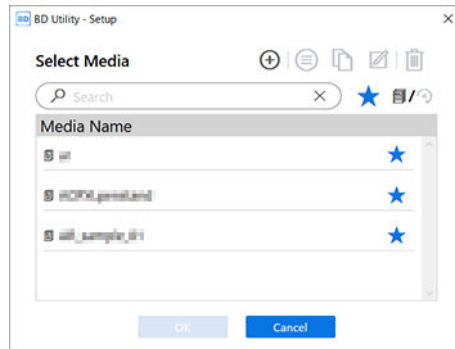

### MEMO

- We recommend that you set frequently used objects as favorites.
  1. Click  next to the name of a registered object to change this icon to .
  2. Click  next to the search box.

The icon changes to , and the list of media set as favorites appears.



- You can display all registered objects.  
If a rotary axis unit is not attached, the normal objects are displayed. If a rotary axis unit is attached, the objects to be used with this unit are displayed.  
Click  /  or  /  to display all registered objects.

- **For pre-registered objects**

Select the object, and then click [OK].

#### MEMO

You can use the favorites function and the search function to easily find registered objects.

Steps 3 through 5 are not required. Proceed to step 6.

#### IMPORTANT



If the height may have changed due to a change in the securing method, suction mat, or similar, set the height (step 4).

**3. In the [Object Type] window, select one of the following, and then click [OK].**

- [Transparent]: A hand placed on the other side of the object can be seen through it.
- [Opaque]: A hand placed on the other side of the object cannot be seen through it.

See [Object \(Media\) Registration Items](#) for more information on objects.

**4. Click [Change] next to [Flat Table Height] to set the height of the object.**

- (1) Click  or  on the right side of the window to align the highest point of the object with the forward-back position of the head gap sensor.

#### MEMO

You can select 0.1 mm (0.004 in.), 1 mm (0.04 in.), 10 mm (0.39 in.), or 50 mm (1.97 in.) as the single-click moving distance.

- (2) Click  on the left side of the window to have the highest point of the object approach the head gap sensor.

Move the highest printing position of the object up to a position (a) a few mm away from the head gap sensor without coming into contact with the head gap sensor.

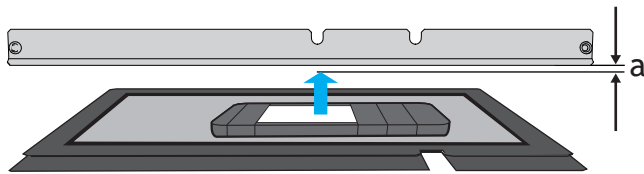

- (3) If the print surface height is not constant or the object is lifted or is warped, set the [Flat Table Lowering Amount].

[P. 126 Setting a Longer Distance between the Object and the Print Heads](#)

- (4) Click [Automatic Setup].

The flat table moves and the head gap sensor detects the height of the object.

- (5) Click [OK].

5. Select [Print Origin] from [Origin Relative] or [Center Relative].

For information about [Print Origin], refer to [Object \(Media\) Registration Items](#).

6. Click [Change] next to [Print Origin] and [Printing Area], and then set the printable area.





This section explains how to configure settings when the [Origin Relative] is selected. If the distance from the lower right (S: 0 mm [0 in.], F: 0 mm [0 in.]<sup>\*1</sup>) of the maximum printing area is clear, use [Numeric Input] to enter a numerical value.

**MEMO**

When the [Printing Area] setting is finished, the print-head carriage returns to its original position after it has been left in the same position for approximately 3 minutes to prevent the print heads from drying out. Perform the procedure again.

- (1) Select [Pointer] for [Position Specification].

The print-head carriage moves, and then the pointer on the right side of the print-head carriage illuminates the lower right (S: 0 mm [0 in.], F: 0 mm [0 in.]) of the maximum printing area.

- (2) Click , , , or , and then move the pointer to specify the print origin (lower right of the printing area).

The print-head carriage moves in the left-right direction and the flat table moves in the forward-backward direction. The position that the pointer illuminates serves as the [Print Origin].

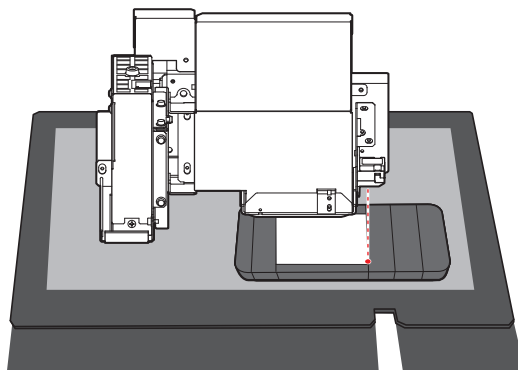

- (3) Click [OK].

Return to the Table Height, Print Origin, and Printing Area settings window.

<sup>\*1</sup> "S" indicates the scan direction (left/right) and "F" indicates the feed direction (forward/backward).

**IMPORTANT**

**About [Printing Area]**

Since the [Origin Relative] is specified here, the upper left of the [Printing Area] is automatically set to the maximum position (S: 210 mm [8.26 in.], F: 148 mm [5.82 in.]).

**7. Click [OK].**

[Setup in progress.] is displayed. When setup is completed, you are returned to the home screen, and the registered object name, and the set [Flat Table Height], [Print Origin], and [Printing Area] are displayed.

## Step 4: Perform Printing

Prints from FlexiDESIGNER. When you start FlexiDESIGNER, VersaWorks is also started. VersaWorks should be left running as it is used to process print data.

### MEMO

Depending on the computer display settings, the [Send to Device] or [Print parameters] window may not fit on the monitor. If this occurs, adjust the magnification and layout in the display settings.

### Procedure

1. Open the saved print data.
2. Click .  
The [Send to Device] dialog box appears.
3. In [Device], select the output machine (BD-8).
4. Click [Print parameters] and set the printing details.
5. Click [Send].  
Printing starts.

### MEMO

If you created the print data using commercially-available application software, it will be printed from VersaWorks. For more information, see VersaWorks Help.

### RELATED LINKS

- [Introduction to FlexiDESIGNER](#)
- [P. 87 Print Parameters \(FlexiDESIGNER\)](#)
- [VersaWorks Help](#)

# Determining the Printing Position Using Captured Images

First, print the alignment markers. After printing the markers, place the object on the flat table, and then take a picture of it using a smartphone. Import the photo data you have captured into FlexiDESIGNER to create the print data.

Use this printing method for printing that does not really require a lot of printing positions or printing sizes, such as when printing with a single point.

## IMPORTANT

- **It is not suitable for objects with height.**

Since the height of the printed surface cannot be detected, objects with a thickness of 3 mm (0.12 in.) or more will have a significant printing position misalignment.

This is because the printed surface is in a position closer to the camera than the alignment markers by virtue of its thickness, and the area of the object is larger by virtue of its proximity. Therefore, printing on thicker objects will be printed slightly larger.

- **It is not suitable for printing all the way to the edges of objects.**

Because it is difficult to detect the edges of the object, printing position misalignment may be significant.

## MEMO

Use the following link to view a reference video for this procedure. We recommend that you view this video to understand the overall flow of work.

[https://youtu.be/e7o7rG--i\\_s](https://youtu.be/e7o7rG--i_s)

## Step 1: Alignment Marker Printing

Print alignment markers (10 mm × 10 mm [0.39 in. × 0.39 in.]) near the four corners of the maximum printing area.

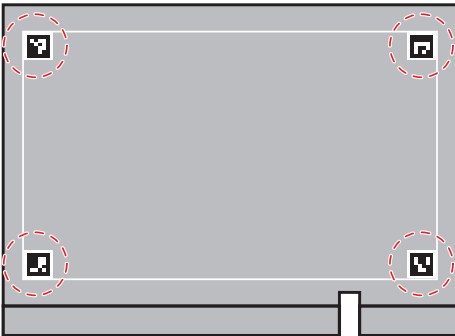

## Procedure

1. Press the sub power button.
2. Open the front cover.
3. Affix single-color tape to the position shown in the figure on the flat table.

## MEMO

We recommend white tape to reduce printing time for alignment markers.

- The affixing area (A) should be at least 12 mm (0.48 in.) from the white line.

- If the white line of the maximum printing area is transparent, apply the tape over the white line until it is no longer transparent or use non-transparent tape.

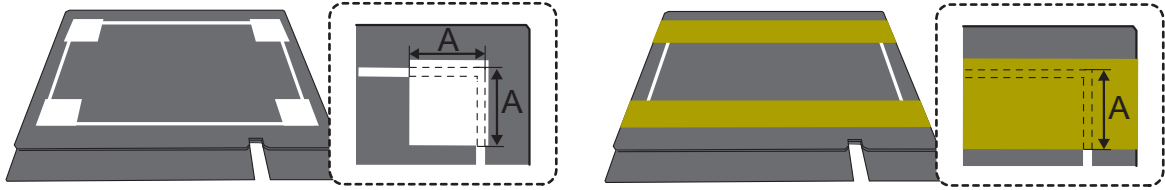

4. Close the front cover.
5. Set up the tape pasted in step 3 in the maximum printing area.  
Specify the print origin as S: 0 mm (0 in.), F: 0 mm (0 in.) in [Origin Relative]. If you do not specify the printing area, it will be set to W: 210 mm (8.27 in.), L: 148 mm (5.83 in.).
6. On the Utility home screen, click .
7. Click [Preferences], and then click [Execute] for [Alignment Marker Printing].
8. If the tape in step 3 is white-colored, clear the [Print White Alignment Marker Background] check box.
9. Click [OK].  
Printing starts.
10. When printing is finished, click [Close].
11. Click [Cancel Setup].
12. Click [OK].

### RELATED LINKS

- [P. 18 Printable Area](#)

## Step 2: Placing and Imaging the Object

### Procedure

1. Open the front cover.

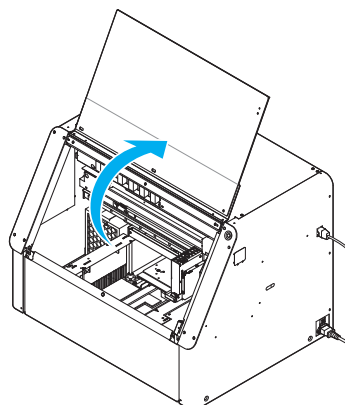

2. Place the object within the printing area on the flat table (inside the white line).

- (1) Place the object.

You cannot use the included adhesive sheet because it hides the alignment markers. Cut before use, or fix the object so that it will not shift.

- (2) If necessary, perform the following operations.

- Use a static removal brush or anti-static cloth to eliminate static electricity from the object.
- Degrease the printing area of the object using anhydrous ethanol or isopropyl alcohol.

3. Keep the following points in mind when performing imaging with a smartphone.

- Focus on the alignment marker.

Perform imaging by focusing on the alignment markers, not the object.

- All the alignment markers in the four corners should be included in the captured image.

If the alignment markers are hidden or missing, the position cannot be detected. Perform imaging so that all four alignment markers are included in the captured image.

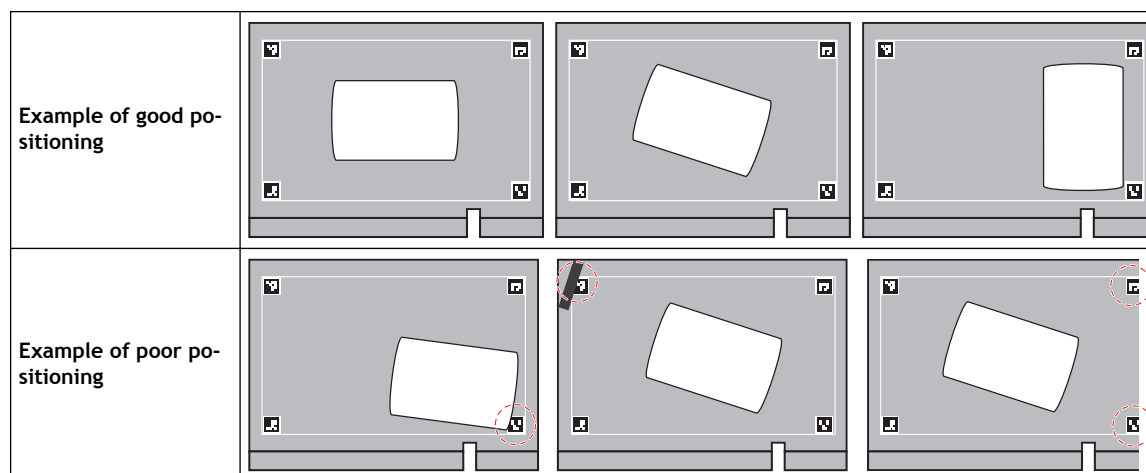

- Perform imaging from directly above the object.



Perform imaging as shown in the following figure so that the edges of the object can be detected more easily. Perform imaging so that the sides of the object are not captured, especially for thicker objects.

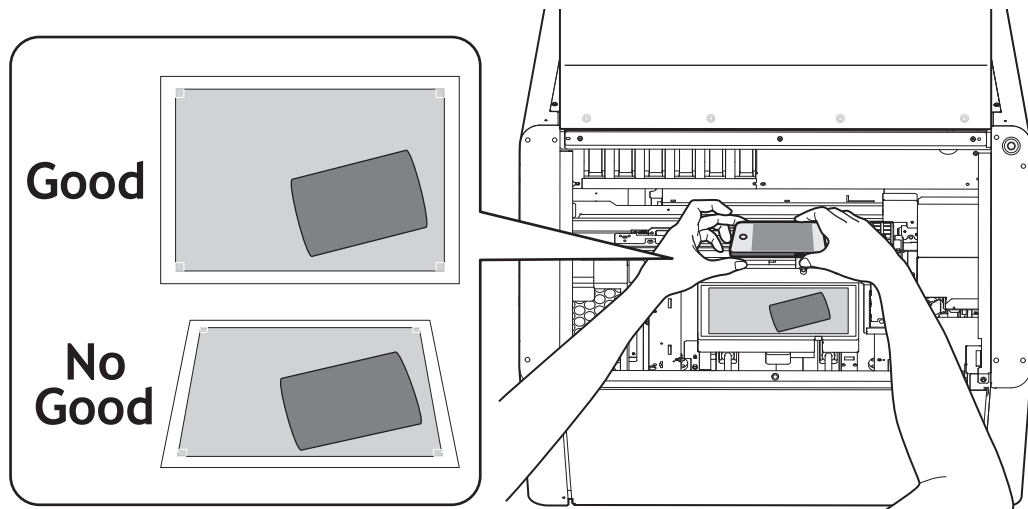

- Save imaging data in jpeg or HEIC format.

If you are using a model that does not support the .jpeg or .HEIC photo data format,<sup>\*1</sup> change the save format to jpeg or HEIC, or convert the data to jpeg or HEIC before importing.

4. Save the imaging data to your computer.

### RELATED LINKS

- [P. 212 Printing Position Using Alignment Markers Is Misaligned](#)
- [P. 214 Alignment Markers Cannot Be Read](#)

<sup>\*1</sup> Some Apple products have a default save format of HEIC.

## Step 3: Setting Up the Object

Place the object, and then make it ready for printing.

### IMPORTANT

You can set the flat table height while keeping a close eye on it by working with the front cover open. However, clicking [OK] in these settings may cause the flat table to start moving. Therefore, when the front cover is open, be careful not to touch any moving parts as you work.

### Procedure

1. On the Utility home screen, click  [Setup].

2. Register/select the object.

### MEMO

In Utility, "media" is used on the window used to register/manage objects.

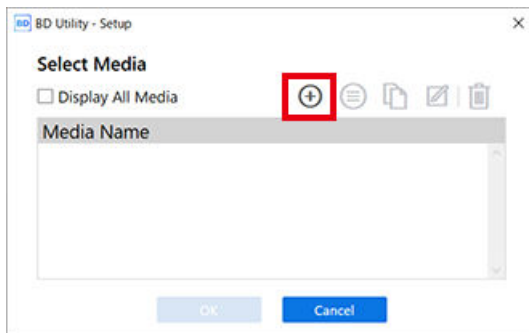

- When printing on an object for the first time
  - a. Click .

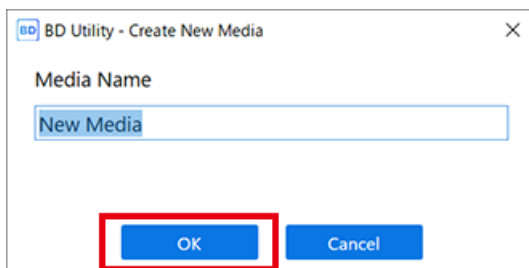

- b. Enter the name of the new object, and then click [OK].  
Previously registered media names cannot be used. Enter a new media name.





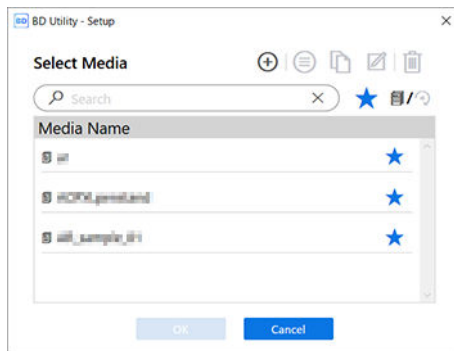

### MEMO

- We recommend that you set frequently used objects as favorites.
  1. Click  next to the name of a registered object to change this icon to .
  2. Click  next to the search box.

The icon changes to  , and the list of media set as favorites appears.



- You can display all registered objects.  
If a rotary axis unit is not attached, the normal objects are displayed. If a rotary axis unit is attached, the objects to be used with this unit are displayed.  
Click  /  or  /  to display all registered objects.

- For pre-registered objects  
Select the object, and then click [OK].

**MEMO**

You can use the favorites function and the search function to easily find registered objects.



Steps 3 and 4 are not required. Proceed to step 5.

**IMPORTANT**

If the height may have changed due to a change in the suction mat or similar, set the height (step 4).

3. In the [Object Type] window, select one of the following, and then click [OK].
  - [Transparent]: A hand placed on the other side of the object can be seen through it.
  - [Opaque]: A hand placed on the other side of the object cannot be seen through it.
 See [Features of ECO-UV \(EUV5\) Inks](#) for more information on objects.

4. Click [Change] next to [Flat Table Height] to set the height of the object.

- (1) Click  or  on the right side of the window to align the highest point of the object with the forward-back position of the head gap sensor.

**MEMO**

You can select 0.1 mm (0.004 in.), 1 mm (0.04 in.), 10 mm (0.39 in.), or 50 mm (1.97 in.) as the single-click moving distance.

- (2) Click  on the left side of the window to have the highest point of the object approach the head gap sensor.

Move the highest printing position of the object up to a position (a) a few mm away from the head gap sensor without coming into contact with the head gap sensor.

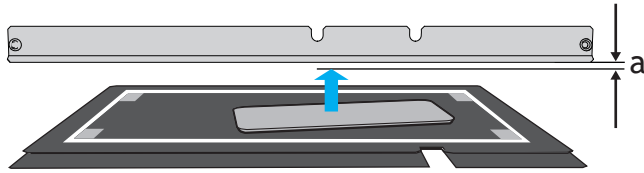

- (3) If the print surface height is not constant or the object is lifted or is warped, see below to set the [Flat Table Lowering Amount].

[P. 126 Setting a Longer Distance between the Object and the Print Heads](#)

- (4) Click [Automatic Setup].

The flat table moves and the head gap sensor detects the height of the object.

- (5) Click [OK].

5. Click [OK].

If the [Printing Area] is not set, the maximum printing area (W: 210 mm × L: 148 mm [W: 8.26 in. × L: 5.82 in.]) becomes the [Printing Area] by default. If you are printing using alignment markers, set to the maximum printing area.

[Setup in progress.] is displayed. When setup is completed, you are returned to the home screen, and the registered media name, and the set [Flat Table Height], [Print Origin], and [Printing Area] are displayed.

## Step 4: Creating Data while Checking the Position

### Procedure

1. Follow the procedure below to start FlexiDESIGNER.
  - (1) Start Roland DG Connect Hub.
    - Windows 11
      - i. Click [Start]>[All apps].
      - ii. From the list of apps (programs), click [Roland DG Corporation]>[Roland DG Connect Hub].
    - Windows 10
      - i. Click [Start].
      - ii. From the list of apps (programs), click [Roland DG Corporation]>[Roland DG Connect Hub].
  - (2) Click the machine (BD-8) to use.
  - (3) Click [Open] for FlexiDESIGNER.
2. Follow the procedure below to import the photo file saved in [Step 1: Alignment Marker Printing into FlexiDESIGNER](#).
  - (1) Click [File]>[Open AR Photo].

The file selection window opens.
  - (2) Select the photographed image file, and then click [Import...].

The captured image is cropped to the size of the four alignment markers (210 mm × 148 mm [8.27 in. × 5.83 in.]) and is displayed in the design area.

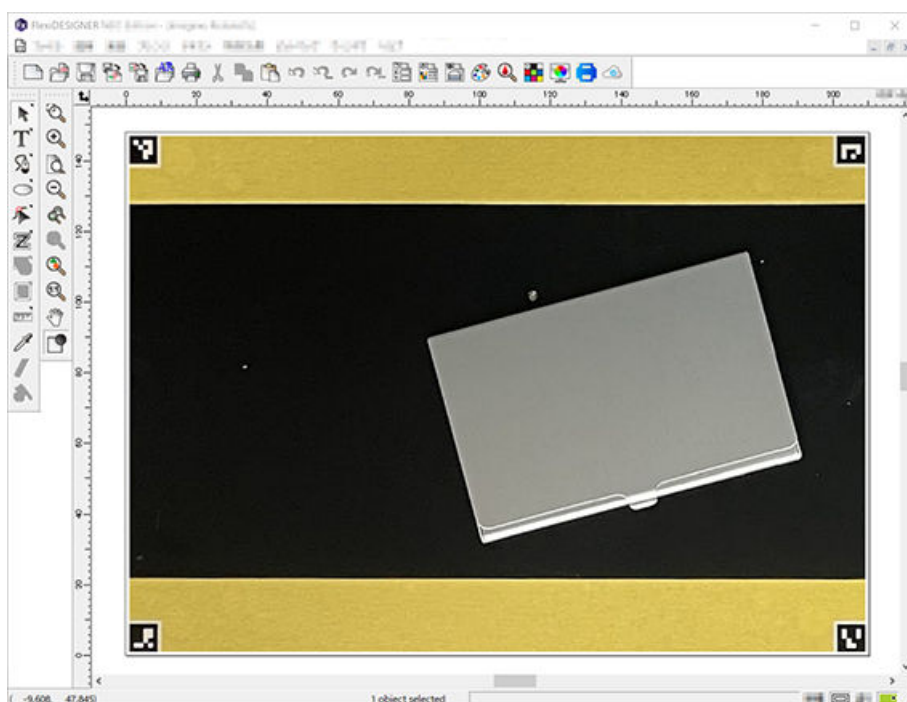

### MEMO

If the alignment markers cannot be read, [Conversion failed the original image will be used.] is displayed. Refer to [Alignment Markers Cannot Be Read](#) to perform imaging again and reading again.

### 3. Create and save the print data.

Print data is created with the object in the background, so you can work while visualizing how it will look after printing.

See "Introduction to FlexiDESIGNER" for information on creating print data.

### RELATED LINKS

- [Introduction to FlexiDESIGNER](#)
- [P. 212 Printing Position Using Alignment Markers Is Misaligned](#)

## Step 5: Perform Printing

### MEMO

Depending on the computer display settings, the [Send to Device] or [Print parameters] window may not fit on the monitor. If this occurs, adjust the magnification and layout in the display settings.

### Procedure

1. Open the saved print data.
2. Click .  
The [Send to Device] dialog box appears.
3. Check the following.
  - [Device]: BD-8
  - [Number of prints]: 1
  - [Output]: Page
4. Click [Print parameters] and set the printing details.  
Set [Media Type] and [Mode] on the [Quality] tab. Set as appropriate depending on whether Pr or Wh is used and on the print data.
5. Click [Send].  
Printing starts.
6. Once printing is complete, remove the object, and exit out of setup in Utility.

### RELATED LINKS













- [Introduction to FlexiDESIGNER](#)
- [P. 87 Print Parameters \(FlexiDESIGNER\)](#)

# Print Parameters (FlexiDESIGNER)

Selecting different options for the [Media Type] and [Mode] print parameters allows for different types of printing. These different types are listed below.

[Media Type]	[Quality]	[Mode]	Description
[General]	[High Speed] [Standard] [High Quality]	[CMYK] [White->CMYK] [CMYK->White] [White]	This is used for general objects or an object that has a smooth print surface.
[Text Decoration]	[High Speed] [Standard]	[CMYK] [White->CMYK] [CMYK->White] [White]	Suitable for simple printing, such as initials or shapes in a single point, or printing on a small area.
[Generic Distance]	[High Speed] [Standard]	[CMYK] [White->CMYK] [CMYK->White] [White]	Used for objects with a print surface that is 2 mm (0.08 in.) or more uneven or spherical in shape. Printing time is longer compared to [General].
[Generic with Primer]	[High Speed] [Standard] [High Quality]	[Primer->CMYK] [Primer->White->CMYK] [Primer->CMYK->White] [Primer->White]	Used for printing primer under [General].
[Text Decoration with Primer]	[High Speed] [Standard]	[Primer->CMYK] [Primer->White->CMYK] [Primer->CMYK->White] [Primer->White]	Used for printing primer under [Text Decoration].
[Generic Distance with Primer]	[High Speed] [Standard]	[Primer->CMYK] [Primer->White->CMYK] [Primer->CMYK->White] [Primer->White]	Used for printing primer under [Generic Distance]. Printing time is longer compared to [Generic with Primer].

## Examples of [Media Type] and [Mode] selection

<p><u>When Printing CMYK on Wh</u> Select [General] and [Wh-&gt;CMYK], and select the [White Plate Generation] check box.</p>	 ←CMYK  ←Wh
<p><u>When Printing Wh on CMYK</u> Select [General] and [CMYK-&gt;Wh], and select the [White Plate Generation] check box.</p>	 ←Wh  ←CMYK
<p><u>When Printing CMYK on Pr</u> Select [Generic with Primer] and [Pr-&gt;CMYK].</p>	 ←CMYK  ←Pr
<p><u>When Printing Wh and CMYK on Pr</u> Select [Generic with Primer] and [Pr-&gt;Wh-&gt;CMYK], and select the [White Plate Generation] check box.</p>	 ←CMYK  ←Wh  ←Pr
<p><u>When Printing CMYK and Wh on Pr</u> Select [Generic with Primer] and [Pr-&gt;CMYK-&gt;Wh], and select the [White Plate Generation] check box.</p>	 ←Wh  ←CMYK  ←Pr



# Printing Examples

---

Printing on Cosmetic Items.....	89
Step 1: Creating Printing Data.....	89
Step 2: Placing and Setting Up the Object .....	92
Step 3: Perform Printing.....	95
Printing on Golf Balls.....	96
Step 1: Creating Printing Data.....	96
Step 2: Placing and Setting Up the Object .....	99
Step 3: Perform Printing.....	102
Printing on Smartphone Cases .....	103
Step 1: Creating Printing Data.....	103
Step 2: Placing and Setting Up the Object .....	106
Step 3: Perform Printing.....	109
Printing on an Acrylic Stand .....	110
Step 1: Creating Printing Data.....	110
Step 2: Placing and Setting Up the Object .....	114
Step 3: Perform Printing.....	117

# Printing on Cosmetic Items

Print text on a powder foundation case.



## Step 1: Creating Printing Data

Measure the printing size of the object, set the printing area, and then create print data.

### MEMO

Follow the procedure below to operate FlexiDESIGNER Ver. 22.0.0, build number 4176. Operation methods may vary depending on the version of FlexiDESIGNER.

## Procedure

### 1. Measure the printing area (print surface of the object).

This is necessary to set the printing area. Make a note of the measurement when you take it. The print surface of the powder foundation case to be printed in this case is 111 mm (4.37 in.) wide, and 71 mm (2.79 in.) long.

### 2. Follow the procedure below to start FlexiDESIGNER.

#### (1) Start Roland DG Connect Hub.

- Windows 11
  - i. Click [Start]>[All apps].
  - ii. From the list of apps (programs), click [Roland DG Corporation]>[Roland DG Connect Hub].
- Windows 10
  - i. Click [Start].
  - ii. From the list of apps (programs), click [Roland DG Corporation]>[Roland DG Connect Hub].

#### (2) Click the machine (BD-8) to use.

#### (3) Click [Open] for FlexiDESIGNER.

### 3. Follow the procedure below to set the size of the printing data.

#### (1) Click the icon (A).

The [DesignCentral] dialog box (B) opens.

#### (2) On the tab (C), click the pull-down menu [▼], and then select [Custom].

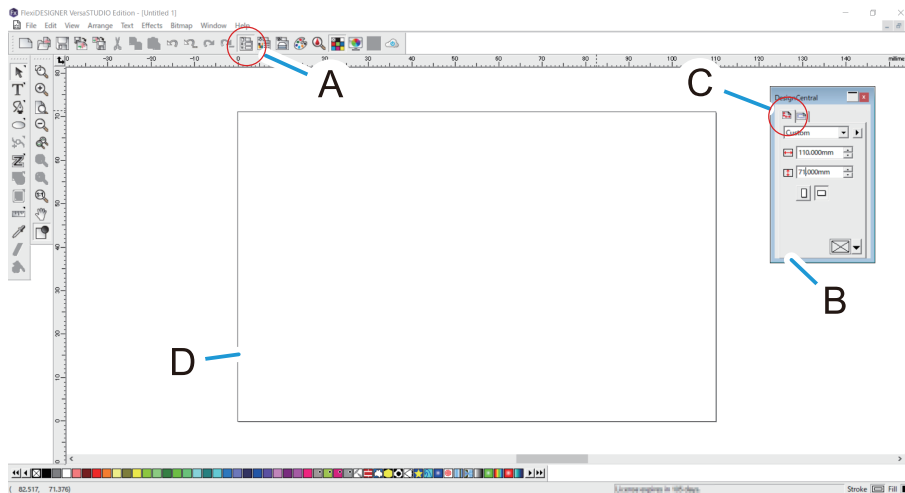

#### (3) Enter the printing size (111 mm, 71 mm [4.37 in., 2.79 in.]) measured in step 1.

A printing size frame (D) is created in the design area.



**4. Create data for printing.**

Enter a name here, and apply a color to the text.

- (1) Click **T** [Text Tool].
- (2) Click a location close to where you want to enter the text, and then enter the text.
- (3) Click  [Select Tool].
- (4) Select the text you entered, and then click the **A** tab in the [DesignCentral] dialog box to adjust the font and size.
- (5) Select the text, and then place them in the desired position.
- (6) Click the  icon.  
The [Fill/Stroke Editor] dialog box opens.
- (7) With the text selected, click the pull-down menu [▼] in the  tab, and then select [Solid fill].
- (8) Select the desired color from the color selection pull-down menu [▼].

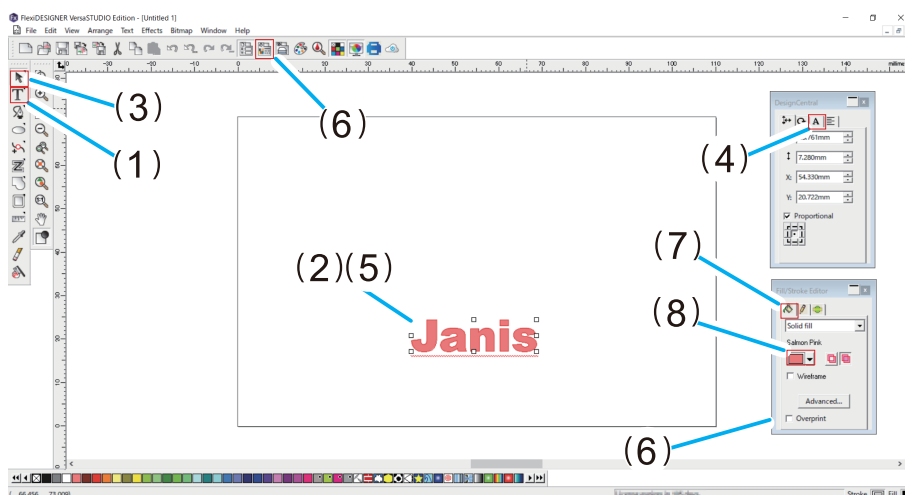

**5. Click [File]>[Save] to save the data.**

**RELATED LINKS**

- [Introduction to FlexiDESIGNER](#)

## Step 2: Placing and Setting Up the Object

Place the object, and then make it ready for printing.

### IMPORTANT

You can keep the front cover open when you set the height of the flat table, the print origin, or other settings for a closer view as you work.  
However, clicking [OK] with these settings configured may cause the print-head carriage or flat table to start moving. Therefore, when the front cover is open, be careful not to touch any moving parts as you work.

### Procedure

**1. Start Utility.**

P. 35 Starting Utility

**2. Place the object.**

(1) If necessary, perform the following operations.

- Use a static removal brush or anti-static cloth to eliminate static electricity from the object.
- Degrease the printing area of the object using anhydrous ethanol or isopropyl alcohol.
- Protect the areas other than the printing area with masking tape.

(2) Open the front cover.

(3) Make sure there is no debris or other foreign objects adhered to the flat table.

(4) Place an adhesive sheet on the flat table.

(5) Place the object.

- Print data is printed with the data rotated 180 degrees.
- Place the object inside the white border and parallel to the white border.

(6) Close the front cover.

**3. Set up the object.**

(1) On the Utility home screen, click  [Setup].

(2) Click .

### MEMO

In Utility, "media" is used on the window used to register/manage objects.

Previously registered media names cannot be used. Enter a new media name.

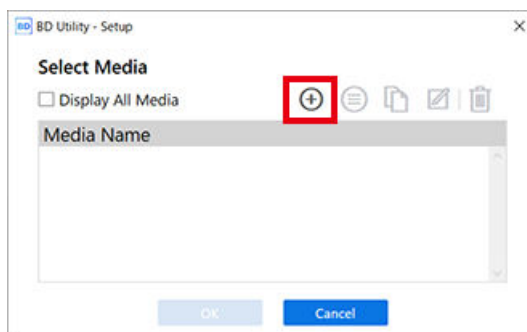

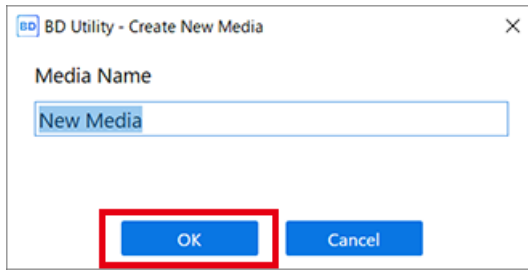

(3) Enter the name of the object, and then click [OK].



(4) Select [Opaque] on the [Object Type] window, and then click [OK].

(5) Click [Change] next to [Flat Table Height] to set the height of the object.

- i. Click  or  on the right side of the window to align the highest point of the object with the forward-back position of the head gap sensor.

**MEMO**

You can select 0.1 mm (0.004 in.), 1 mm (0.04 in.), 10 mm (0.39 in.), or 50 mm (1.97 in.) as the single-click moving distance.

- ii. Click  on the left side of the window to have the highest point of the object approach the head gap sensor.

Move the highest printing position of the object up to a position (a) a few mm away from the head gap sensor without coming into contact with the head gap sensor.

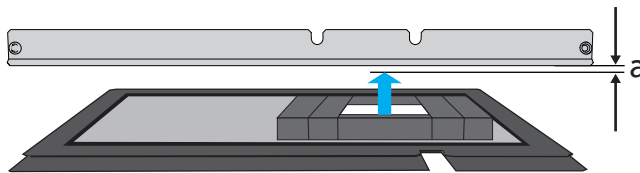

- iii. Click [Automatic Setup].

The flat table moves and the head gap sensor detects the height of the object.

- iv. Click [OK].





(6) Click [Change] for [Print Origin] and [Printing Area], then click [Print Origin].

**MEMO**

When the [Printing Area] setting is finished, the print-head carriage returns to its original position after it has been left in the same position for approximately 3 minutes to prevent the print heads from drying out. Perform the procedure again.

- i. Select [Pointer] for [Position Specification].

The print-head carriage moves, and then the pointer on the right side of the print-head carriage illuminates the lower right (S: 0 mm [0 in.], F: 0 mm [0 in.]) of the maximum printing area.

- ii. Click , , , or , and then move the pointer to specify the print origin (lower right of the printing area).

The print-head carriage moves in the left-right direction and the flat table moves in the forward-backward direction. The position that the pointer illuminates serves as the [Print Origin].

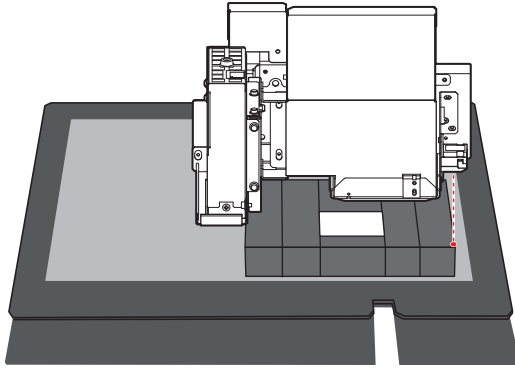

iii. Click **[OK]**.

Returns to the **[Flat Table Height]**, **[Print Origin]**, and **[Printing Area]** settings window.

**MEMO**

**About [Printing Area]**

Since the **[Origin Relative]** is specified here, the upper left of the printing area is automatically set to the maximum position (S: 210 mm [8.26 in.], F: 148 mm [5.82 in.]).

4. Click **[OK]**.

**[Setup in progress.]** is displayed. When setup is completed, you are returned to the home screen, and the registered object name, and the set **[Flat Table Height]**, **[Print Origin]**, and **[Printing Area]** are displayed.

## Step 3: Perform Printing

### MEMO

Depending on the computer display settings, the [Send to Device] or [Print parameters] window may not fit on the monitor. If this occurs, adjust the magnification and layout in the display settings.

### Procedure

1. Open the printing data created in FlexiDESIGNER.  
Click [File]>[Open] to open the saved printing data.
2. Click .  
The [Send to Device] dialog box opens.
3. Check the following.
  - [Device]: BD-8
  - [Number of prints]: 1
  - [Output]:[Page]
4. Click [Print parameters].
5. In the [Quality] tab, select the following.
  - [Media Type]:[Text Decoration]
  - [Print Quality]:[Standard]
  - [Mode]: [CMYK (v)]
6. Click [OK].  
The Print Parameters window closes.
7. Click [Send].  
Printing starts.
8. Once printing is complete, remove the object, and exit out of setup in Utility.

### RELATED LINKS

- [P. 87 Print Parameters \(FlexiDESIGNER\)](#)



# Printing on Golf Balls

Print text and shapes on golf balls.



## MEMO

Use the following link to view a reference video for this procedure. We recommend that you view this video to understand the overall flow of work.

<https://youtu.be/loKdOoNH2vw>

## Step 1: Creating Printing Data

Set the printing size, and then create the print data.

## MEMO

Follow the procedure below to operate FlexiDESIGNER Ver. 22.0.0, build number 4176. Operation methods may vary depending on the version of FlexiDESIGNER.

## Procedure

### 1. Follow the procedure below to start FlexiDESIGNER.

#### (1) Start Roland DG Connect Hub.

- Windows 11
  - i. Click [Start]>[All apps].
  - ii. From the list of apps (programs), click [Roland DG Corporation]>[Roland DG Connect Hub].
- Windows 10
  - i. Click [Start].
  - ii. From the list of apps (programs), click [Roland DG Corporation]>[Roland DG Connect Hub].

#### (2) Click the machine (BD-8) to use.

#### (3) Click [Open] for FlexiDESIGNER.

### 2. Follow the procedure below to set the size of the printing data.

#### (1) Click the icon (A).

The [DesignCentral] dialog box (B) opens.

#### (2) On the tab (C), click the pull-down menu [▼], and then select [Custom].

- (3) Enter the printing size for golf balls.

**IMPORTANT**

For printing on golf balls, set the [Media Type] as follows as appropriate for the printing area.





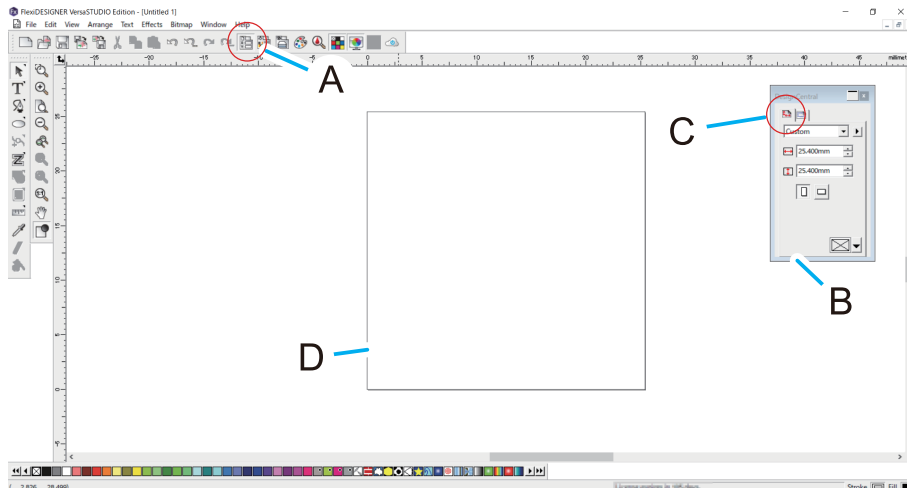



- [General]: Printing area up to 18 mm (0.7 in.) in diameter
- [Generic Distance]: Printing area from 18 mm to 29 mm (0.71 in. to 1.14 in.) in diameter

A printing size frame (D) is created in the design area.



### 3. Create data for printing.

In this section, you design the message and the shapes. Specify the fonts and angles of text, the sizes of shapes, and other parameters.

- (1) Click  [Text Tool].
- (2) Click a location close to where you want to enter the text, and then enter the text.
- (3) Click  [Select Tool], and select the text entry.
- (4) Click the  tab in the [DesignCentral] dialog box, and then adjust the font and size.
- (5) Select the text, and then place them in the desired position.
- (6) Click the  tab to adjust the angle.
- (7) Click the  icon.
- (8) With the text selected, click the pull-down menu in the  tab, and then select [Solid fill].
- (9) Select any color from the pull-down menu.
- (10) Hold down  [Rectangle Tool], and then select  [Starburst Tool].
- (11) Drag near the location where you want to add the shape.  
A star shape will be drawn corresponding to the length of the drag.
- (12) With the shape selected, click the pull-down menu in the  tab, and then select [Solid fill].
- (13) Select any color from the pull-down menu.
- (14) Repeat steps (11) through (13), and then place the shapes.

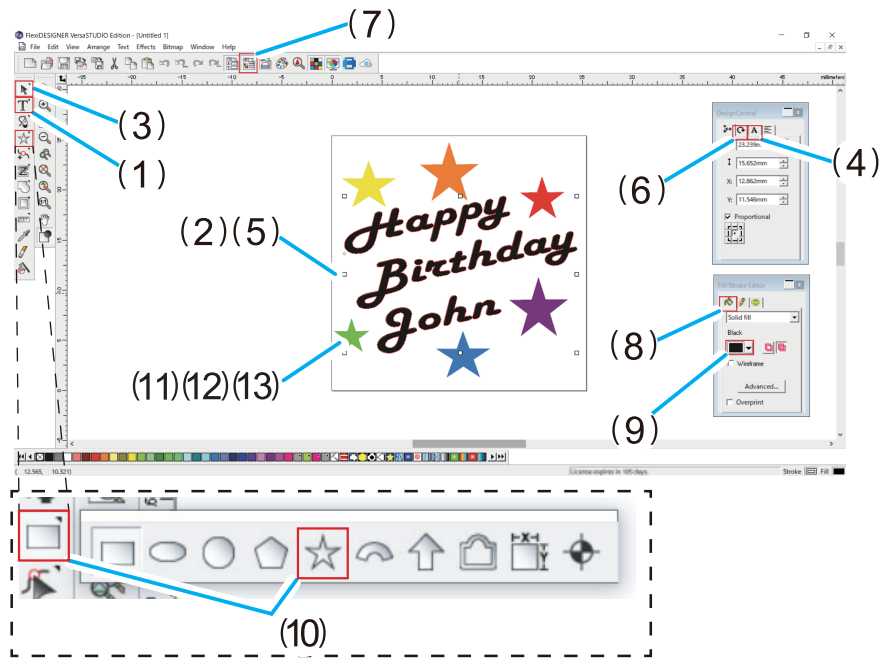

4. Click [File]>[Save] to save the data.

#### RELATED LINKS

- [Introduction to FlexiDESIGNER](#)

## Step 2: Placing and Setting Up the Object

Place the object, and then make it ready for printing.

### IMPORTANT

You can keep the front cover open when you set the height of the flat table, the print origin, or other settings for a closer view as you work. However, clicking [OK] with these settings configured may cause the print-head carriage or flat table to start moving. Therefore, when the front cover is open, be careful not to touch any moving parts as you work.

### Procedure

**1. Start Utility.**

P. 35 Starting Utility

**2. Prepare a jig that ensures a printing area of about 30 mm × 30 mm (1.18 in. × 1.18 in.).**

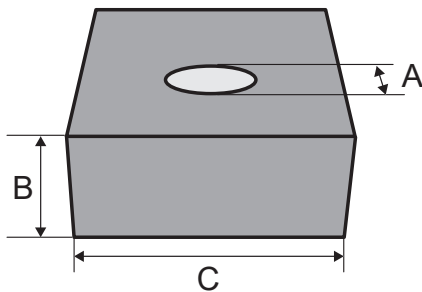



A: Approx. 30 mm (1.18 in.)	B: Approx. 40 mm (1.57 in.)	C: Approx. 100 mm (3.94 in.)
-----------------------------	-----------------------------	------------------------------

**3. Place the object.**

- (1) If necessary, perform the following operations.
  - Use a static removal brush or anti-static cloth to eliminate static electricity from the object.
  - Degrease the printing area of the object using anhydrous ethanol or isopropyl alcohol.
- (2) Open the front cover.
- (3) Make sure there is no debris or other foreign objects adhered to the flat table.
- (4) Place an adhesive sheet on the flat table.
- (5) Place the object and attach the jig.
  - Print data is printed with the data rotated 180 degrees.
  - Jigs made from light material such as paper should also themselves be secured.
- (6) Close the front cover.

**4. Set up the object.**

- (1) On the Utility home screen, click  [Setup].
- (2) Click .

**MEMO**

In Utility, "media" is used on the window used to register/manage objects.

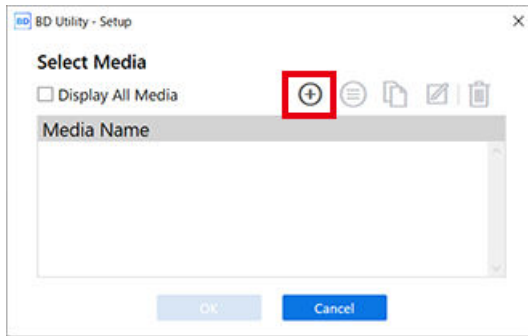

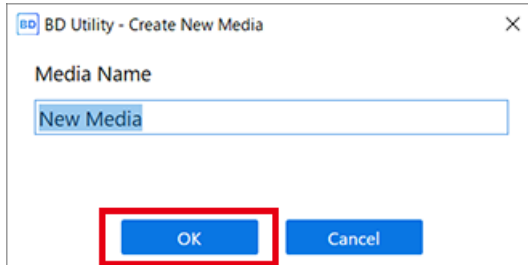

(3) Enter the name of the object, and then click [OK].

Previously registered media names cannot be used. Enter a new media name.



(4) Select [Opaque] on the [Object Type] window, and then click [OK].

(5) Click [Change] next to [Flat Table Height] to set the height of the object.

- i. Click  or  on the right side of the window to align the highest point of the object with the forward-back position of the head gap sensor.

**MEMO**

You can select 0.1 mm (0.004 in.), 1 mm (0.04 in.), 10 mm (0.39 in.), or 50 mm (1.97 in.) as the single-click moving distance.

- ii. Click  on the left side of the window to have the highest point of the object approach the head gap sensor.

Move the highest printing position of the object up to a position (a) a few mm away from the head gap sensor without coming into contact with the head gap sensor.

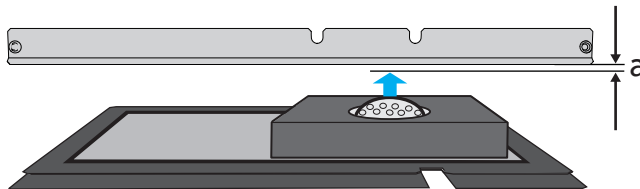

- iii. Click [Automatic Setup].

The flat table moves and the head gap sensor detects the height of the object.

- iv. Click [OK].

(6) Select [Center Relative] in [Print Origin], click [Change], and then set the printable area.

**MEMO**

When the [Printing Area] setting is finished, the print-head carriage returns to its original position after it has been left in the same position for approximately 3 minutes to prevent the print heads from drying out. Perform the procedure again.





Specify the [Printing Area] with the node of the golf ball as the [Print Origin].

i. Select [Pointer] for [Position Specification].

The print-head carriage and the flat table move, and then the pointer on the right side of the print-head carriage illuminates the center of the maximum printing area.





ii. Select [Printing Area].

The print-head carriage and the flat table move, and then the pointer illuminates the upper left of the maximum printing area.

iii. Click , , , or , and then move the pointer to change the [Printing Area] to the print data size.

- The print-head carriage moves in the left-right direction and the flat table moves in the forward-backward direction.
- If you narrow the printing area, you will be able to move the center position.

iv. Select [Center Position].

v. Click , , , or , and then move the pointer to specify the node of the golf ball (the center of the printing area).

The print-head carriage moves in the left-right direction and the flat table moves in the forward-backward direction. The position that the pointer illuminates serves as the center of the printing area.

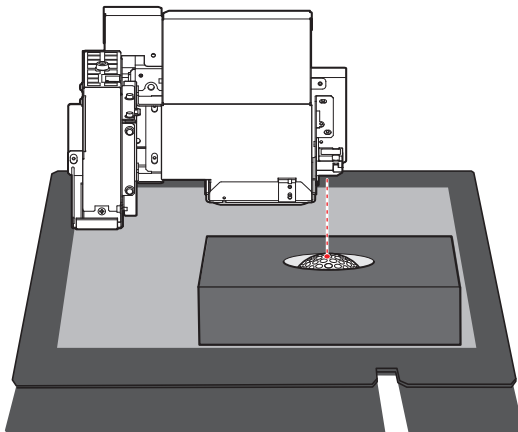

vi. Make sure that the width and length of the [Printing Area] are the same as the print data size.

vii. Click [OK].

Returns to the [Flat Table Height], [Print Origin], and [Printing Area] settings window.

5. Click [OK].

[Setup in progress.] is displayed. When setup is completed, you are returned to the home screen, and the registered object name, and the set [Flat Table Height], [Print Origin], and [Printing Area] are displayed.

## Step 3: Perform Printing

### MEMO

Depending on the computer display settings, the [Send to Device] or [Print parameters] window may not fit on the monitor. If this occurs, adjust the magnification and layout in the display settings.

### Procedure

1. Open the printing data created in FlexiDESIGNER.  
Click [File]>[Open] to open the saved printing data.
2. Click .  
The [Send to Device] dialog box opens.
3. Check the following.
  - [Device]: BD-8
  - [Number of prints]: 1
  - [Output]:[Page]
4. Click [Print parameters].
5. In the [Quality] tab, select the following.
  - [Media Type]: [General] or [Generic Distance]<sup>\*1</sup>
  - [Print Quality]:[Standard]
  - [Mode]: [CMYK (v)]
6. Click [OK].  
The Print Parameters window closes.
7. Click [Send].  
Printing starts.
8. Once printing is complete, remove the object, and exit out of setup in Utility.

### RELATED LINKS

- [P. 87 Print Parameters \(FlexiDESIGNER\)](#)

<sup>\*1</sup> Select [General] if the print data is less than 18 mm (0.70 in.) in diameter. Select [Generic Distance] if the print data is 18 mm (0.70 in.) or more in diameter.

# Printing on Smartphone Cases

Print photos you have taken with your smartphone on a smartphone case.



## MEMO

Use the following link to view a reference video for this procedure. We recommend that you view this video to understand the overall flow of work.

<https://youtu.be/731hOx8RR0A>

## Step 1: Creating Printing Data

Measure the printing size of the object, set the printing area, and then create print data.

## MEMO

Follow the procedure below to operate FlexiDESIGNER Ver. 22.0.0, build number 4176. Operation methods may vary depending on the version of FlexiDESIGNER.

## Procedure

### 1. Measure the printing area (print surface of the object).

This is necessary to set the printing area. Make a note of the measurement when you take it. The printed surface of smartphone cases is 134 mm (5.28 in.) wide and 67 mm (2.64 in.) long when placed horizontally. This time, to print on the entire surface of the case, set the printing area to be larger than the printed surface. Any printing outside of the edges of the printed surface will be wasted, but you can print all the way up to the edges.

### 2. Start FlexiDESIGNER.

#### (1) Start Roland DG Connect Hub.

- Windows 11
  - i. Click [Start]>[All apps].
  - ii. From the list of apps (programs), click [Roland DG Corporation]>[Roland DG Connect Hub].
- Windows 10
  - i. Click [Start].
  - ii. From the list of apps (programs), click [Roland DG Corporation]>[Roland DG Connect Hub].

#### (2) Click the machine (BD-8) to use.

#### (3) Click [Open] for FlexiDESIGNER.



**3. Set the printing area according to the procedure below.**

- (1) Click the  icon (A).

The [DesignCentral] dialog box (B) opens.

- (2) On the  tab (C), click the pull-down menu [▼], and then select [Custom].

- (3) Enter a printing area (136 mm × 69 mm (5.35 in. × 2.72 in.) that is 1 mm (0.04 in.) larger than the printing area measured in step 1 in all four directions, from both front to back and left to right.

A printing area frame (D) is created in the design area.

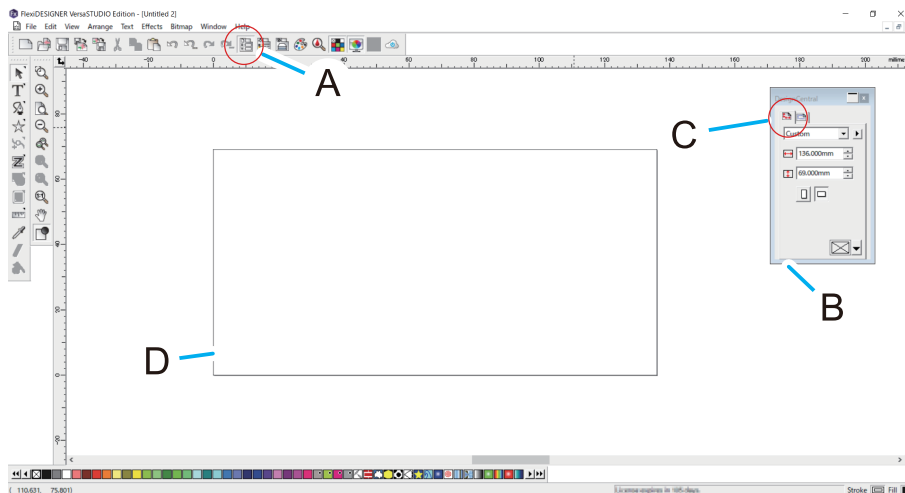



**4. Create data for printing.**

Here, the photos are imported, sized, and trimmed. A primer plate is then created to improve adhesion and a white plate is created to prevent the color of the printed object from showing through.

- (1) Save the photo data to your computer.
- (2) Click [File]>[Import...], select the saved photo data, and then click [Import...].  
The blue dashed frame of the photo data size is displayed in the window.
- (3) Click the desired location, and then paste the photo data into the design area.

**IMPORTANT**

If the photo data size is large, use  [Zoom Out] or "Ctrl + Scroll" to view the entire photo data.

- (4) Select the photo data, and then adjust the size.
  - i. Select the loaded photo data.
  - ii. In the [DesignCentral] dialog box, select the  tab and click .
  - iii. In the [DesignCentral] dialog box, select the [Proportional] check box.
  - iv. Enter a size close to that of the printing area and then press Enter.

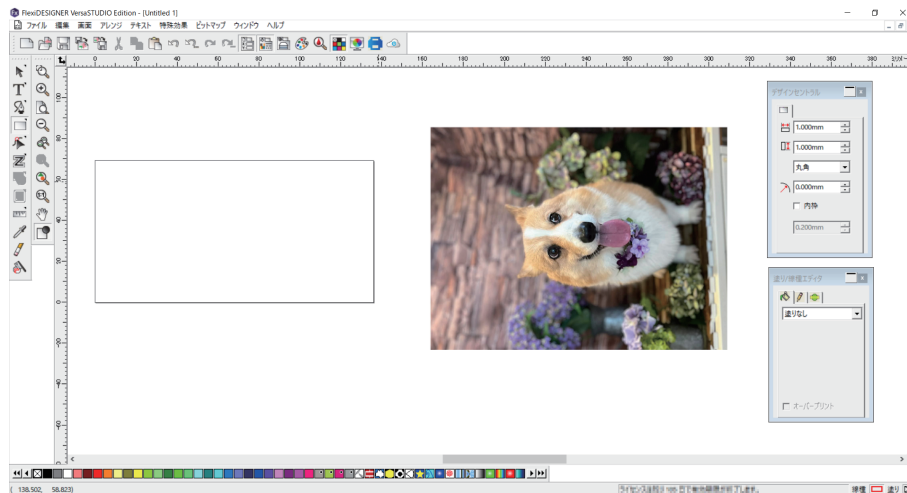

Adjust the size based on the size of the image to be trimmed. Here, set a width of 145 mm (5.71 in.) for the printing area (136 mm, 69 mm [5.35 in., 2.72 in.]).



(5) Perform trimming.

- i. Select  [Rectangle Tool], and create a frame for the printing area (136 mm × 69 mm [5.35 in. × 2.72 in.]).

Since this frame will be used as an outer frame for trimming, click  and then configure the settings as follows.

-  tab:[No fill]
-  tab: Type of line: Solid line; Line color: Red

- ii. Select the  [Select Tool], and then move the frame to determine the position to be trimmed.

- iii. With the image and frame selected with the selection tool, click [Arrange]>[Mask]>[Mask].

The image is trimmed with a red line.

(6) With the image and frame selected, click [Arrange]>[Align]>[Both Centers to Page].

The selected image is placed in the center of the printing area.

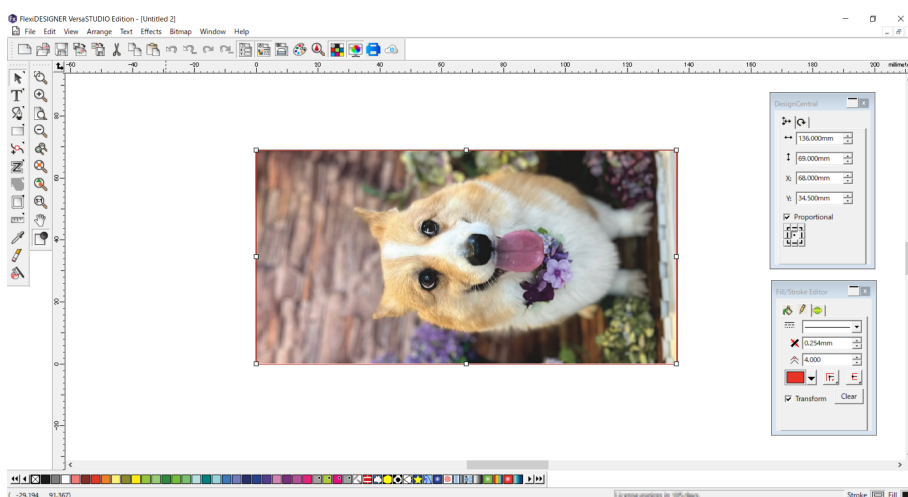

5. Click [File]>[Save] to save the data.

## Step 2: Placing and Setting Up the Object

Place the object, and then make it ready for printing.

### IMPORTANT

You can keep the front cover open when you set the height of the flat table, the print origin, or other settings for a closer view as you work. However, clicking [OK] with these settings configured may cause the print-head carriage or flat table to start moving. Therefore, when the front cover is open, be careful not to touch any moving parts as you work.

### Procedure

#### 1. Start Utility.

P. 35 Starting Utility

#### 2. Place the object.

(1) If necessary, perform the following operations.

- Use a static removal brush or anti-static cloth to eliminate static electricity from the object.
- Degrease the printing area of the object using anhydrous ethanol or isopropyl alcohol.
- Protect the areas other than the printing area with masking tape.

In this case, the printing area is set wider than the object in order to print to the edges of the object. Protect the sides of the object and the hole in the printing area from being exposed to ink mist.

(2) Open the front cover.

(3) Make sure there is no debris or other foreign objects adhered to the flat table.

(4) Place an adhesive sheet on the flat table.

(5) Place the object.

- Print data is printed with the data rotated 180 degrees.
- Place the object inside the white border and parallel to the white border.

(6) Close the front cover.

#### 3. Set up the object.

### MEMO

In Utility, "media" is used on the window used to register/manage objects.

(1) On the Utility home screen, click  [Setup].

(2) Click .

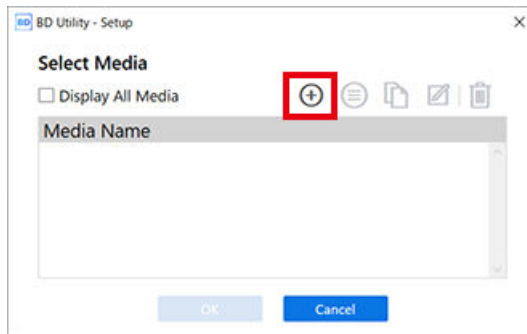

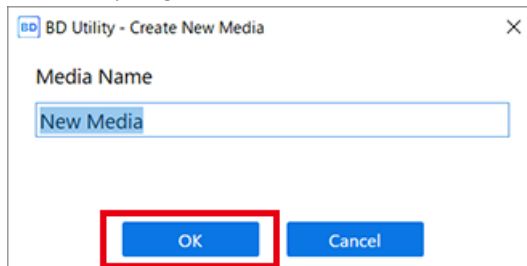

- (3) Enter the name of the object, and then click [OK].

Previously registered media names cannot be used. Enter a new media name.



- (4) Select [Opaque] on the [Object Type] window, and then click [OK].  
 (5) Click [Change] next to [Flat Table Height] to set the height of the object.

- i. Click  or  on the right side of the window to align the highest point of the object with the forward-back position of the head gap sensor.

**MEMO**

You can select 0.1 mm (0.004 in.), 1 mm (0.04 in.), 10 mm (0.39 in.), or 50 mm (1.97 in.) as the single-click moving distance.

- ii. Click  on the left side of the window to have the highest point of the object approach the head gap sensor.

Move the highest printing position of the object up to a position (a) a few mm away from the head gap sensor without coming into contact with the head gap sensor.

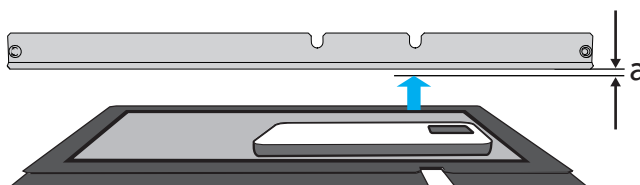





- iii. Click [Automatic Setup].  
 The flat table moves and the head gap sensor detects the height of the object.  
 iv. Click [OK].  
 (6) Click [Change] for [Print Origin] and [Printing Area], then click [Print Origin].

**MEMO**

When the [Printing Area] setting is finished, the print-head carriage returns to its original position after it has been left in the same position for approximately 3 minutes to prevent the print heads from drying out. Perform the procedure again.

- i. Select [Pointer] for [Position Specification].

The print-head carriage moves, and then the pointer on the right side of the print-head carriage illuminates the lower right (S: 0 mm [0 in.], F: 0 mm [0 in.]) of the maximum printing area.

- ii. Click , , , or , and then move the pointer to specify the print origin (lower right of the printing area).

The print-head carriage moves in the left-right direction and the flat table moves in the forward-backward direction. The position that the pointer illuminates serves as the print origin.

Since the print data this time will be larger than the printing area by 1 mm (0.04 in.) in each direction, specify a print origin outside the printing area where "a" in the figure below is 1 mm (0.04 in.).

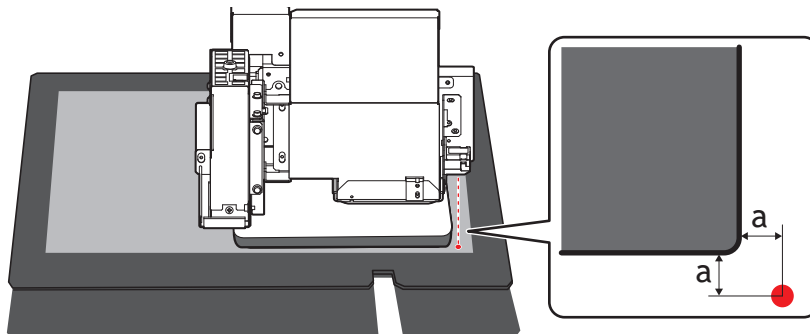

- iii. Click [OK].

Returns to the [Flat Table Height], [Print Origin], and [Printing Area] settings window.

**MEMO**

**Printing area**

Since the [Origin Relative] is specified here, the upper left of the printing area is automatically set to the maximum position (S: 210 mm [8.26 in.], F: 148 mm [5.82 in.]).

4. Click [OK].

[Setup in progress.] is displayed. When setup is completed, you are returned to the home screen, and the registered object name, and the set [Flat Table Height], [Print Origin], and [Printing Area] are displayed.

## Step 3: Perform Printing

### MEMO

Depending on the computer display settings, the [Send to Device] or [Print parameters] window may not fit on the monitor. If this occurs, adjust the magnification and layout in the display settings.

### Procedure

1. Open the printing data created in FlexiDESIGNER.  
Click [File]>[Open] to open the saved printing data.
2. Click .  
The [Send to Device] dialog box opens.
3. Check the following.
  - [Device]: BD-8
  - [Number of prints]: 1
  - [Output]:[Page]
4. Click [Print parameters].
5. In the [Quality] tab, select the following.
  - [Media Type]:[General]
  - [Print Quality]:[High Quality]
  - [Mode]: [White->CMYK (v)]
  - [Special Color Plate Generation]
    - [White Plate Generation]: Select the check box.
    - [Generated Pattern]:[Print Area]
    - [Size Correction]:[No]
6. Click [OK].  
The Print Parameters window closes.
7. Click [Send].  
Printing starts.
8. Once printing is complete, remove the object, and exit out of setup in Utility.

### RELATED LINKS

- [P. 87 Print Parameters \(FlexiDESIGNER\)](#)

# Printing on an Acrylic Stand

Print photos and text in reverse from the back of a transparent acrylic shield. White is printed behind the photo and text to properly express colors of the print data.



## MEMO

Use the following link to view a reference video for this procedure. We recommend that you view this video to understand the overall flow of work.

<https://youtu.be/ud6ygZ9zvbc>

## Step 1: Creating Printing Data

Measure the printing size of the object, set the printing area, and then create print data.

## MEMO

Follow the procedure below to operate FlexiDESIGNER Ver. 22.0.0, build number 4176. Operation methods may vary depending on the version of FlexiDESIGNER.

## Procedure

### 1. Measure the printing area (print surface of the object).

This is necessary to set the printing area. Make a note of the measurement when you take it. The printing area of the acrylic stand is 130 mm (5.12 in.) wide and 90 mm (3.54 in.) long when placed horizontally. Put the cropped photo and message in this printing area, mirror it, and then print it.

### 2. Start FlexiDESIGNER.

#### (1) Start Roland DG Connect Hub.

- Windows 11
  - i. Click [Start]>[All apps].
  - ii. From the list of apps (programs), click [Roland DG Corporation]>[Roland DG Connect Hub].
- Windows 10
  - i. Click [Start].
  - ii. From the list of apps (programs), click [Roland DG Corporation]>[Roland DG Connect Hub].

#### (2) Click the machine (BD-8) to use.

#### (3) Click [Open] for FlexiDESIGNER.

**3. Set the printing area according to the procedure below.**

- (1) Click the  icon (A).

The [DesignCentral] dialog box (B) opens.

- (2) On the  tab (C), click the pull-down menu [▼], and then select [Custom].

- (3) Enter the printing area (130 mm × 90 mm [5.12 in. × 3.54 in.]).

A printing area frame (D) is created in the design area.

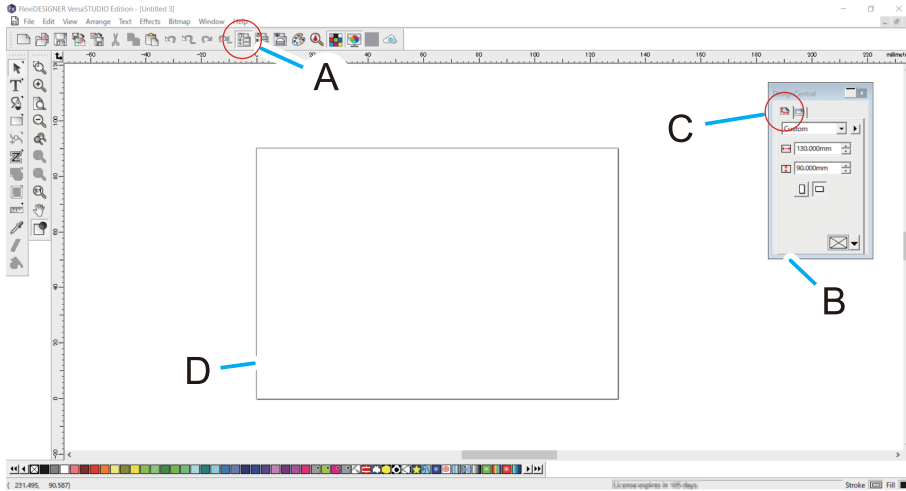

**4. Create data for printing.**

Here, the photos are imported, sized, and trimmed. The message is then added, the photo and text are mirrored, and then a white plate is created to prevent the colors of the printed object from showing through.

- (1) Save the photo data to your computer.
- (2) Click [File]>[Import...], select the saved photo data, and then click [Import...].  
The blue dashed frame of the photo data size is displayed in the window.
- (3) Click the desired location, and then paste the photo data into the design area.

**MEMO**

If the photo data size is large, use  [Zoom Out] or "Ctrl + Scroll" or other means to view the entire photo data.



- (4) Select the photo data, and then adjust the size.
  - i. Select the loaded photo data.
  - ii. In the [DesignCentral] dialog box, select the [Proportional] check box.
  - iii. Enter a size close to that of the printing area and then press Enter.

Adjust the size based on the size of the image to be trimmed. Here, set a width of 150 mm (5.90 in.) for the printing area (130 mm × 90 mm [5.12 in., 3.54 in.]).

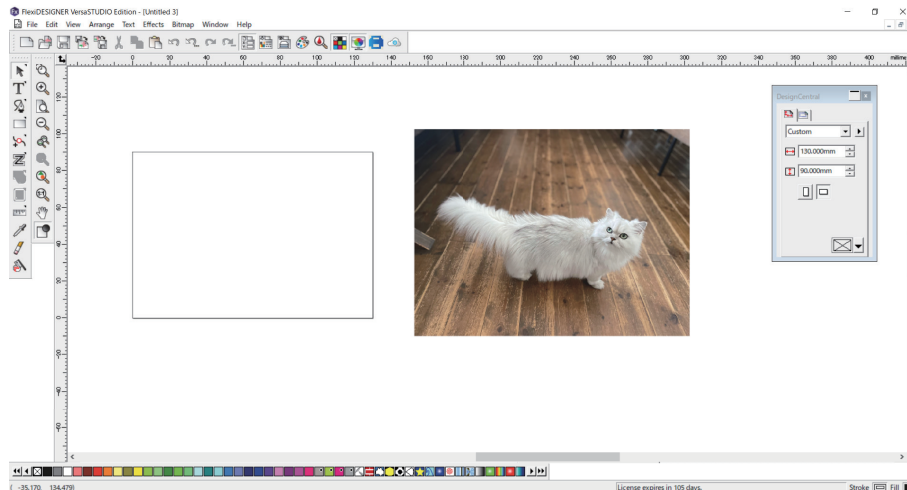





### (5) Perform trimming.

- i. Hold down  [Rectangle Tool], and then select  [Oval Tool].

Since this frame will be used as an outer frame for trimming, click  and then configure the settings as follows.

-  tab:[No fill]
-  tab: Type of line: Solid line; Line color: Red

- ii. Select the  [Select Tool], and then move the frame to determine the position to be trimmed.

- iii. With the image and frame selected with the selection tool, click [Arrange]>[Mask]>[Mask].

The image is trimmed with a red line.

- iv. Use the [Select Tool] to move the photo to the frame of the printing area and check that there are no problems with the size.

Zoom in/out using the [DesignCentral] dialog box or the interface item around the selected photo.

### (6) Place the message.

- i. Select the  [Text Tool].

- ii. Click a location close to where you want to enter the text, and then enter the text.

- iii. Click  [Select Tool], and select the text entry.

- iv. Click the  tab in the [DesignCentral] dialog box, and then adjust the font and size.

- v. Use  [Select Tool] and select the message, then click [Arrange]>[Convert to Outlines].

The message text are converted to the state of shapes (they do not change in appearance) so they can be mirrored.

- vi. Change the color and lines of the [Fill/Stroke Editor] dialog box.

### (7) Mirror the photo and message.

- i. Select the photo and message in the  [Select Tool].

- ii. Click [Arrange]>[Mirror...], and then press Enter.

The photo will be inverted, centered on the right side.

- (8) With the image and message selected, click [Arrange]>[Align]>[Vertical Center to Page].

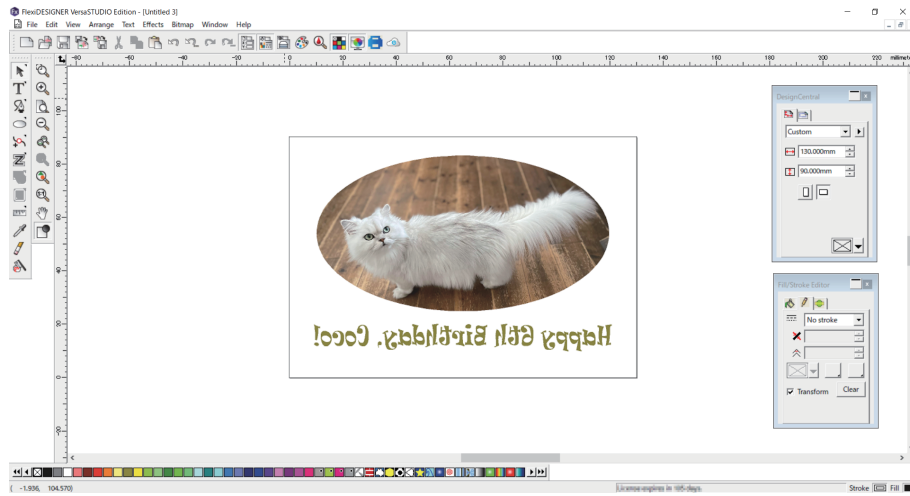

The selected photo and message will be placed in the vertical center of the printing area.

5. Click [File]>[Save] to save the data.

## Step 2: Placing and Setting Up the Object

Place the object, and then make it ready for printing.

### IMPORTANT

You can keep the front cover open when you set the height of the flat table, the print origin, or other settings for a closer view as you work.  
However, clicking [OK] with these settings configured may cause the print-head carriage or flat table to start moving. Therefore, when the front cover is open, be careful not to touch any moving parts as you work.

### Procedure

#### 1. Start Utility.

P. 35 Starting Utility

#### 2. Place the object.

(1) If necessary, perform the following operations.

- Use a static removal brush or anti-static cloth to eliminate static electricity from the object.
- Degrease the printing area of the object using anhydrous ethanol or isopropyl alcohol.
- Protect the areas other than the printing area with masking tape.

(2) Open the front cover.

(3) Make sure there is no debris or other foreign objects adhered to the flat table.

(4) Place an adhesive sheet on the flat table.

(5) Place the object.

- Print data is printed with the data rotated 180 degrees.
- Place the object inside the white border and parallel to the white border.

(6) Close the front cover.

#### 3. Set up the object.

### MEMO

In Utility, "media" is used on the window used to register/manage objects.

(1) On the Utility home screen, click  [Setup].

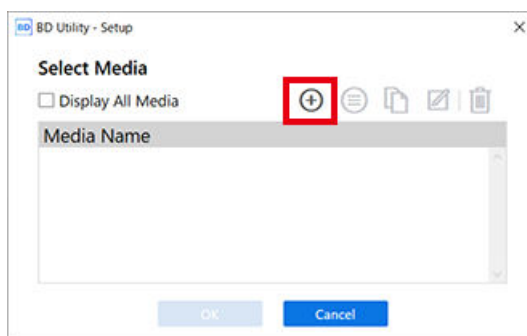

(2) Click .

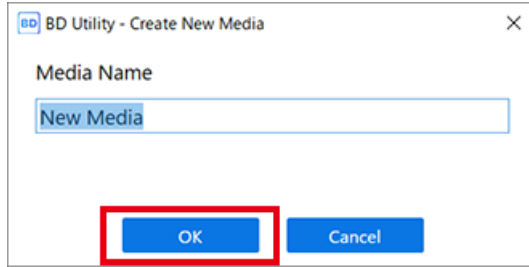

(3) Enter the name of the object, and then click [OK].

Previously registered media names cannot be used. Enter a new media name.



- (4) Select [Transparent] on the [Object Type] window, and then click [OK].
- (5) Click [Change] next to [Flat Table Height] to set the height of the object.
  - i. Click  or  on the right side of the window to align the highest point of the object with the forward-back position of the head gap sensor.

**MEMO**

You can select 0.1 mm (0.004 in.), 1 mm (0.04 in.), 10 mm (0.39 in.), or 50 mm (1.97 in.) as the single-click moving distance.

- ii. Click  on the left side of the window to have the highest point of the object approach the head gap sensor.



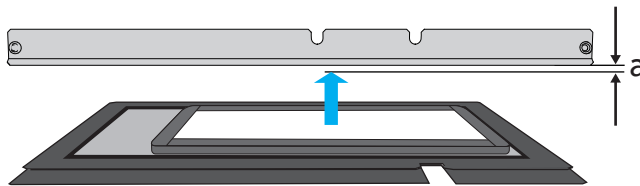

Move the highest printing position of the object up to a position (a) a few mm away from the head gap sensor without coming into contact with the head gap sensor.



- iii. Click [Automatic Setup].  
The flat table moves and the head gap sensor detects the height of the object.
  - iv. Click [OK].
- (6) Click [Change] for [Print Origin] and [Printing Area], then click [Print Origin].

**MEMO**

When the [Printing Area] setting is finished, the print-head carriage returns to its original position after it has been left in the same position for approximately 3 minutes to prevent the print heads from drying out. Perform the procedure again.

- i. Select [Pointer] for [Position Specification].  
The print-head carriage moves, and then the pointer on the right side of the print-head carriage illuminates the lower right (S: 0 mm [0 in.], F: 0 mm [0 in.]) of the maximum printing area.
- ii. Click , , , or , and then move the pointer to specify the print origin (lower right of the printing area).  
The print-head carriage moves in the left-right direction and the flat table moves in the forward-backward direction. The position that the pointer illuminates serves as the [Print Origin].

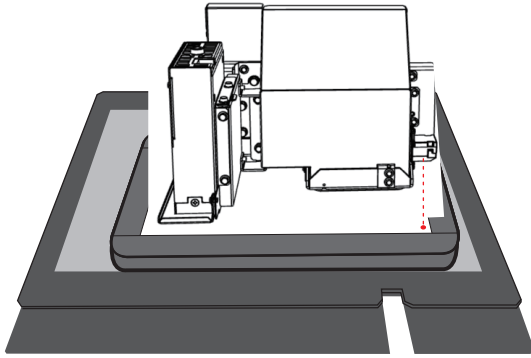

iii. Click **[OK]**.

Returns to the **[Flat Table Height]**, **[Print Origin]**, and **[Printing Area]** settings window.

### MEMO

#### About **[Printing Area]**

Since the **[Origin Relative]** is specified here, the upper left of the printing area is automatically set to the maximum position (S: 210 mm [8.26 in.], F: 148 mm [5.82 in.]).

4. Click **[OK]**.

**[Setup in progress.]** is displayed. When setup is completed, you are returned to the home screen, and the registered object name, and the set **[Flat Table Height]**, **[Print Origin]**, and **[Printing Area]** are displayed.

## Step 3: Perform Printing

### MEMO

Depending on the computer display settings, the [Send to Device] or [Print parameters] window may not fit on the monitor. If this occurs, adjust the magnification and layout in the display settings.

### Procedure

1. Open the printing data created in FlexiDESIGNER.  
Click [File]>[Open] to open the saved printing data.
2. Click .  
The [Send to Device] dialog box opens.
3. Check the following.
  - [Device]: BD-8
  - [Number of prints]: 1
  - [Output]: [Page]
4. Click [Print parameters].
5. In the [Quality] tab, select the following.
  - [Media Type]: [General]
  - [Print Quality]: [High Quality]
  - [Mode]: [CMYK->White]
  - [Special Color Plate Generation]
    - [White Plate Generation]: Select the check box.
    - [Generated Pattern]: [Print Area]
    - [Size Correction]: [No]
6. Click [OK].  
The Print Parameters window closes.
7. Click [Send].  
Printing starts.
8. Once printing is complete, remove the object, and exit out of setup in Utility.

### RELATED LINKS

- [P. 87 Print Parameters \(FlexiDESIGNER\)](#)

# Settings

# Efficiency Settings

---

Reducing Print Time .....	120
Minimizing Print-head Carriage Movement .....	120



# Reducing Print Time

## Minimizing Print-head Carriage Movement

This shortens printing time by narrowing the print-head carriage movement to the width of the print data. This feature is effective when the print area or print data has a small width.

Because the default setting is [Output Data Width], there is no effect if this setting is not changed.

### Procedure

1. Set up the object.

[P. 72 Setting Up the Object](#)

2. On the Utility home screen, click .

3. Click the [List of Media Settings]>[Printing Movement Range] pull-down menu.

4. Select [Output Data Width].

The following three settings are available for [Printing Movement Range]. This setting affects printing time and print quality, and should be set as appropriate for the situation.

Settings	Features
[Output Data Width]	Matches the range of print-head carriage movement to the printing data. Movement is limited to the minimum amount necessary, and this can be expected to yield the fastest printing. When this feature is used, the time needed for the ink to harden is not constant, and an uneven color may result.
[Media Width]	Matches the print-head carriage movement range to the set printing area.
[Full Width]	The print-head carriage moves from one end of the machine to the other. This setting makes the speed of print-head carriage movement constant at all times and produces the most stable printing results.

5. Click [Apply] to confirm your entry.

6. Click [Close] to return to the original screen.

#### MEMO

- Default setting: [Output Data Width]

# Quality Settings

---

Flat Table Height Setting .....	122
Readjusting Height during Printing .....	123
Setting a Longer Distance between the Object and the Print Heads .....	126
Setting the Reference Position of the Flat Table in the Vertical Direction.....	128
White Ink Density Maintenance Settings .....	129
Setting the [Ink Circulation] Interval.....	129

# Flat Table Height Setting

---

In the following cases, settings related to the flat table height need to be configured.

- Printing in layers (i.e., the printing surface gradually becomes higher).
- The height of the object changes during printing due to lifting up or warping of the printed object.
- Mass-producing an object whose height varies due to differences among individual objects without changing the height of the registered media.

There are two height settings for the flat table.

- **[Readjust]**

The height of the flat table is readjusted when the print heads come into contact with the object during printing.

[P. 123 Readjusting Height during Printing](#)

- **[Flat Table Lowering Amount]**

Printing is performed by lowering the flat table in advance below the specified value.

[P. 126 Setting a Longer Distance between the Object and the Print Heads](#)

## Readjusting Height during Printing

This setting allows the height to be readjusted to continue printing even when the object comes into contact with the head gap sensor in the following cases.

- When the object becomes loose or warps during printing
- When the print surface is raised due to printing on stacked objects

This function is effective when using objects that cannot be reprinted on.

However, this setting has the following disadvantages.

- Printing time is longer because of the time required for readjustment.
- The print surface comes into contact with the head gap sensor.

Therefore, **[Readjust]** should be used for printing for which you want to ensure image quality even if it takes longer or printing that cannot be redone.

### MEMO

- When the height is readjusted automatically and printing continues, the height setting is changed. Therefore, the print quality may be changed. Hence, proper printing requires that the object to be printed on be secured properly before printing to keep it from moving out of position or lifting up.
- Select **[Readjust]** to automatically adjust the height when the head gap sensor touches the object.
- Even if **[Readjust]** is selected, printing and setup will be canceled in the following cases.
  - When the height reaches the **[Maximum Value (Threshold)]** of automatic adjustment
  - When the object to be printed on comes into contact with the head gap sensor during automatic readjustment, even if the flat table has moved to the bottom
- If this function is not used (**[Operation on Height Error Detection]:[Stop]**), printing is stopped when a height error is detected during printing, and **[Flat Table Height Error]** is displayed.

## Procedure

1. On the Utility home screen, click .
2. Click **[Preferences]**.
3. Select **[Readjust]** for **[Operation on Height Error Detection]** under **[Clearance Settings]**.
4. Click **[▲][▼]** next to **[Maximum Value (Threshold)]** to set the maximum amount by which the flat table is lowered when a height error is detected.

The height adjustment is made gradually until the object no longer touches the head gap sensor. Set this in anticipation of height variations, such as when there are changes in the height of the object.

### MEMO

The greater the distance between the print surface and the print heads, the lower the print quality tends to be. It is preferable to make smaller adjustments. Keep the following points in mind when determining the **[Maximum Value (Threshold)]**.

- Consider the effect on the printing image quality in order to obtain satisfactory image quality.
- The variation in height across the entire print surface (not the print target area but including parts that will not be printed)

5. Click **[Apply]** to confirm your entry.
6. Click **[Close]** to return to the original screen.

### MEMO

- Default settings
  - [Operation on Height Error Detection]:[Stop]
  - [Maximum Value (Threshold)] when [Readjust] is selected: 10 mm (0.39 in.)

## Reflecting the Readjusted Flat Table Height in the Media Settings Values

This section explains how to reflect the flat table height for which [Readjust] has been performed in the media settings. You can overwrite the height of the flat table for registered media.

When printing on the same object, the registered media settings values are used. You can turn on this setting to reduce the time for [Readjust] if the height of the object varies or if the height of the object changes due to layered printing.

Print time is reduced, but print quality tends to be lower because the distance between the print heads and the object is lengthened. If print quality is important to you regardless of whether it takes more time to print, you should turn off this setting.

### Procedure

1. On the Utility home screen, click .
2. Click [Preferences].
3. Select the [Maintain Height after Readjustment] check box for [Clearance Settings] - [Operation on Height Error Detection].
4. Click [Apply] to confirm your entry.
5. Click [Close] to return to the original screen.

#### MEMO

- Default settings
  - [Maintain Height after Readjustment]: Cleared

## Setting a Longer Distance between the Object and the Print Heads

When the object is set up, the distance between the print heads and the object is set at 1.0 mm (0.04 in.). However, the object and print heads may come into contact with each other in the following cases.

- When the height of the object changes due to lifting or warping of the object during printing
- When mass-producing an object whose height varies due to differences among individual objects without changing the height of the registered media

[Flat Table Height Error] appears when the head gap sensor comes in the contact with the object. Therefore, you can increase the distance between the print object and the print heads in advance with [Flat Table Lowering Amount], which can be longer than the standard 1.0 mm (0.04 in.).

The flat table is lowered by the [Flat Table Lowering Amount] in advance, so the distance between the object and the print heads becomes longer. This tends to result in lower print quality, but print time remains the same. However, since the maximum of [Flat Table Lowering Amount] is 2.0 mm (0.07 in.), if the height of the object varies by 2.0 mm (0.07 in.) or more, adjust the height setting as needed, or incorporate [Readjust] into the operation.

[Flat Table Lowering Amount] should be used when print time is a priority.

### IMPORTANT

- This setting is enabled when the height of the object to be printed on is set automatically.
- If the distance is made too long, the print quality may be deteriorated and the nozzles of the print heads may be clogged.
- Set the printing area so that the difference between the highest printing position of the object and the lowest printing position of the print surface is within 2 mm (0.08 in.) (excluding the [Generic Distance]).



### Procedure

1. Place an object that is not of uniform height on the flat table.

2. On the Utility home screen, click  [Setup].

3. Register the object.

To change the height of an already registered object, proceed from step (4).

- (1) Click .
- (2) Enter the name of the object, and then click [OK].
- (3) Select [Transparent] or [Opaque] on the [Object Type] window, and then click [OK].
- (4) Click [Change] next to [Flat Table Height] to set the height of the object.
- (5) Click  next to [Flat Table Lowering Amount], and then set the amount by which the flat table is lowered.

[Flat Table Lowering Amount]*1	Distance between print heads and object*2
0.0 mm (0.0 in.)	1.0 mm (39.4 mil)
0.1 mm (3.94 mil)	1.1 mm (0.04 in.)
:	:
1.9 mm (0.07 in.)	2.9 mm (0.11 in.)
2.0 mm (0.08 in.)	3.0 mm (0.12 in.)

\*1 Can be set in 0.1 mm (3.94 mil) increments.

\*2 The highest position

---

(6) Click [OK].

4. Set the print origin.

5. Click [OK].

[Setup in progress.] is displayed, and then setup is performed with the specified [Flat Table Lowering Amount].

**MEMO**

- Default setting: 0.0 mm (0.0 in.)



## Setting the Reference Position of the Flat Table in the Vertical Direction

Select whether the base position (0 mm [0 in.]) in the flat table height direction should be set to "Lowest position: Height (H)" or "Highest position: Thickness (T)."

### Procedure

1. On the Utility home screen, click .
2. Click [Preferences].
3. In [Flat Table Height/Object (Media) Thickness], select one of the following.

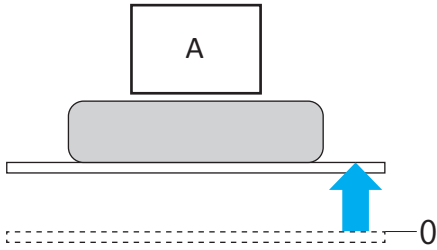
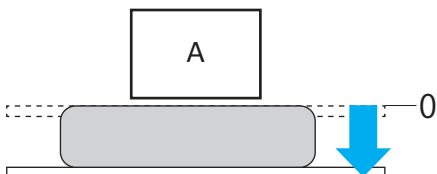
[Height] (H)		Set the base position (0 mm [0 in.]) as the lowest position of the flat table. This indicates how much the flat table rises when the object is set up (flat table height: H).
[Thickness] (T)		Set the highest position of the flat table to 0 mm. This indicates how much the flat table lowers when the object is set up (object thickness: T).

A: Print heads

4. Click [Apply] to confirm your entry.
5. Click [Close] to return to the original screen.

#### MEMO

- Default setting: [Height (Lowered Flat Table Treated as Height of 0)]

# White Ink Density Maintenance Settings

The ingredients in white ink tend to settle. White ink cartridges can be routinely shaken to mix the ink, but you can mix the ink paths inside the printer by performing **[Ink Circulation]**. If there is unevenness in the white ink color, set the frequency of **[Ink Circulation]** to ensure the white ink concentration.

## Setting the **[Ink Circulation]** Interval

You can set the **[Ink Circulation]** interval from 30 minutes to 360 minutes in 30-minute increments. However, if you set the interval too short, you will have to wait more frequently while the ink is circulating.

### Procedure

1. On the Utility home screen, click .
2. Click **[Preferences]**.
3. Set the interval for performing **[Ink Circulation]** in **[Ink Circulation Interval]**.  
The **[Ink Circulation]** operation will take a few minutes. Set the intervals as appropriate for your situation.
4. Click **[Apply]** to confirm your entry.
5. Click **[Close]** to return to the original screen.

#### MEMO

- Default setting: 360 minutes

# Advanced Settings

---

Preferences .....	131
Removing/Attaching Optional Items (OA-RA-8) .....	131
Setting the Deodorizer Mode .....	132
Setting the Deodorizer Pause Time (Strong Mode Only).....	133
Setting the Activation Interval for Sleep Mode (Power-saving Feature) .....	134
Adjusting the Date and Time .....	135
Setting the Language .....	136
Setting the Base Position of the Manual Cleaning Tool .....	137
Adjusting the Pointer Position.....	139
Checking the Height of the Object before Printing.....	141
System Settings .....	142
Changing the Units of Measurement .....	142
Viewing Printer Information .....	143
Viewing Network Information .....	144
Checking the Utility Version .....	145
Changing the Network Settings .....	146

# Preferences

---

## Removing/Attaching Optional Items (OA-RA-8)

For information on removing/installing the OA-RA-8, see the OA-RA-8 User's Manual.

<https://downloadcenter.rolanddg.com/BD-8>

### MEMO

Use the following link to view a reference video for this procedure. We recommend that you view this video to understand the overall flow of work.

<https://youtu.be/g5oVgQ9NXdl>

## Setting the Deodorizer Mode

### Procedure

1. On the Utility home screen, click .
2. Click [Preferences].
3. Set the following with [Deodorizer Settings].

- **Mode**

Mode	Deodorizing performance	Suction power default settings
[Strong]	Activated when main power is on, sub power is on, or during printing. This setting emits the least amount of odor to the exterior of the machine. This mode reduces odors coming out of openings in the machine even when the machine is not in use. In this mode, you can set the pause time for the deodorizer.	<ul style="list-style-type: none"> <li>• [When Printing]: 50%</li> <li>• [When Sub Power On]: 40%</li> <li>• [When Main Power On]: 20%</li> </ul>
[Medium]	Activated when sub power is on, or during printing. This mode reduces odors when the front cover is opened during operations such as loading objects.	<ul style="list-style-type: none"> <li>• [When Printing]: 50%</li> <li>• [When Sub Power On]: 40%</li> </ul>
[Weak] <sup>*1</sup>	Activated only during printing. This mode is intended for users in backyards and other areas that are normally unoccupied and well-ventilated.	<ul style="list-style-type: none"> <li>• [When Printing]: 50%</li> </ul>
[Off]	Deodorizing not activated.	—

\*1 Default settings

- **Suction Power**

You can set the suction power for each state. It can be set between 20% and 100% in 10% increments.

4. Click [Apply] to confirm your entry.
5. Click [Close] to return to the original screen.

### RELATED LINKS

- [P. 26 Deodorizer](#)
- [P. 133 Setting the Deodorizer Pause Time \(Strong Mode Only\)](#)

## Setting the Deodorizer Pause Time (Strong Mode Only)

You can specify a time to pause the deodorizer to prevent premature clogging of the filter, to save standby power, to reduce noise during late-night operation, or for other reasons.

The conditions under which the deodorizer will pause are as follows.

- [Strong] mode
- When main power on or in sleep mode

### Procedure

1. On the Utility home screen, click .
2. Click [Preferences].
3. Select the [Suspension Time Settings] check box in [Deodorizer Settings].
4. Specify [Suspension Period] and [Resume At].
5. Click [Apply] to confirm your entry.
6. Click [Close] to return to the original screen.

#### MEMO

- Default setting: Cleared

## Setting the Activation Interval for Sleep Mode (Power-saving Feature)

Set the amount of time until sleep mode (the state in which the power-saving features operate) activates when the sub power is on and no print data has been received or operations have been performed in Utility for a long period of time. You can set the [Sleep Time] from 15 to 120 minutes in 15 minute increments.

### Procedure

1. On the Utility home screen, click .
2. Click [Preferences].
3. Set the [Sleep Time].
4. Click [Apply] to confirm your entry.
5. Click [Close] to return to the original screen.

#### MEMO

- Default setting: 30 Minutes

---

## Adjusting the Date and Time

The machine remembers the date and time internally and then prints it out in a nozzle drop-out test. Adjust the date and time if it becomes inaccurate over time or if you move to a place with a time difference.

### Procedure

1. On the Utility home screen, click .
2. Click [Preferences].
3. Set the date and time with [Date and Time].
  - **When matching the computer's date and time**  
Select the [Use Date and Time Obtained from Computer] check box.
  - **When setting the date and time**  
Enter the year, month, day, hour, minute, and second manually.
4. Click [Apply] to confirm your entry.
5. Click [Close] to return to the original screen.



## Setting the Language

### Procedure

1. On the Utility home screen, click .
2. Click [System Information].
3. Set the language to use in [Language].
4. Click [Apply] to confirm your entry.
5. Click [Close] to return to the original screen.  
Exit Utility. The language change will be applied when you restart.

## Setting the Base Position of the Manual Cleaning Tool

When the manual cleaning tool is replaced due to damage or deformation, set the base position.

### IMPORTANT





You can use the pointer to adjust the base position while keeping a close eye on it by working with the front cover open.

However, clicking [OK] with these settings configured may cause the print-head carriage or flat table to start moving. Therefore, when the front cover is open, be careful not to touch any moving parts as you work.

### Procedure

1. Remove the object, and then cancel the setup.
2. On the Utility home screen, click .
3. Click [Preferences].
4. Click [Execute] under [Adjust Manual Cleaning Tool Position].  
If in a setup state, [Execute] will be unavailable.
5. Follow the instructions on the Utility window to adjust the position of the manual cleaning tool.
  - (1) When the [This starts manual cleaning tool position adjustment.] window appears, click [OK].
  - (2) Open the front cover.
  - (3) Attach a new manual cleaning tool.
  - (4) Close the front cover.
  - (5) Click [OK].

The print-head carriage and flat table move, and then the pointer illuminates near the base position of the manual cleaning tool.

- (6) Click , , , or  to align the pointer to the manual cleaning tool reference position.

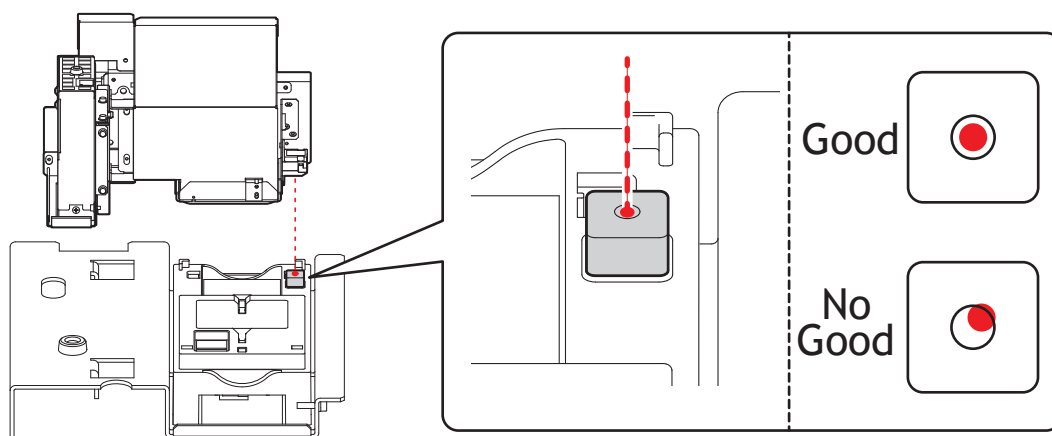

- (7) Click [OK].

The print-head carriage and flat table return to their original positions.

- (8) When [Remove the manual cleaning tool.] is displayed, open the front cover and remove the manual cleaning tool.
- (9) Click [OK].
- (10) Close the front cover.

**6.** Click [Close] to return to the original screen.

## Adjusting the Pointer Position

Adjust the pointer's printing position if there is misalignment between the printing area set by the pointer and the actual printing.

### IMPORTANT

You can use the pointer to adjust the base position while keeping a close eye on it by working with the front cover open. However, clicking [OK] with these settings configured may cause the print-head carriage or flat table to start moving. Therefore, when the front cover is open, be careful not to touch any moving parts as you work.

### Procedure

1. Set up the nozzle drop-out test paper.  
P. 31 Registering and Setting Up the Nozzle Drop-out Test Paper
2. On the Utility home screen, click .
3. Click [Preferences].
4. Click [Execute] under [Position Adjustment]>[Adjust Pointer Position].
5. When the [This prints the position adjustment pattern.] window appears, click [OK].  
After printing a pattern for position adjustment the pointer illuminates near the printed pattern.

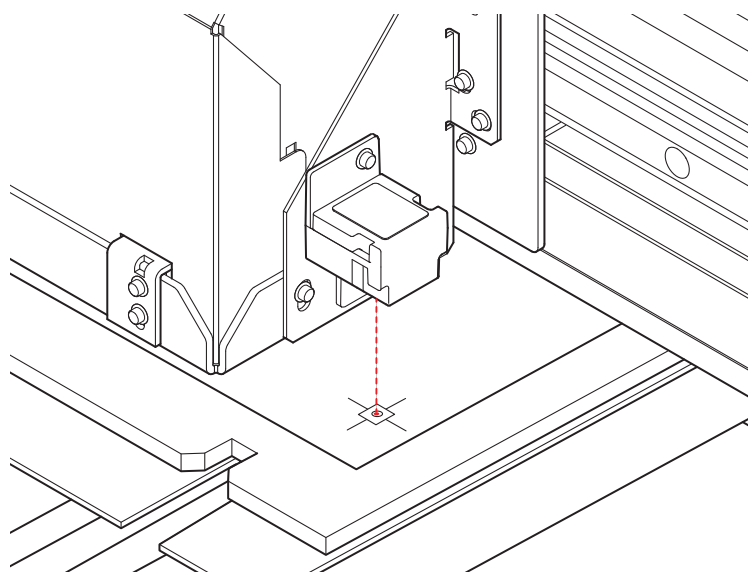

6. Adjust the position of the pointer.  
(1) Click , , , and  to move the pointer inside the inner square.

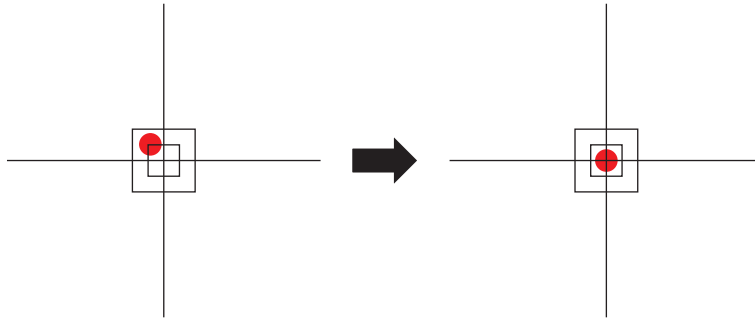

(2) Click [OK].

The corrected pointer position is applied and the sub power is turned off.

## Checking the Height of the Object before Printing

When you have finished setting up the object, the clearance between the head gap sensor (A) and the object (B) is set to 0.5 mm (0.02 in.)\*1.

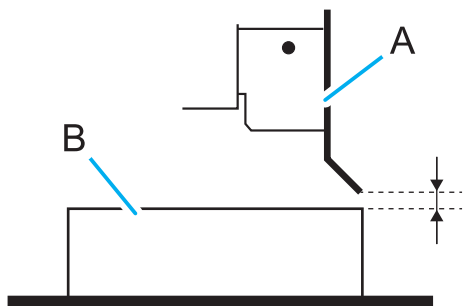

This machine prints while the object moves from the front to the back (from the right to the left in the above figure).

Depending on the object, the height may change after setup due to such factors as warping of the media causing the tape that secured the object to peel off. In such cases, the object may come into contact with the head gap sensor and damage it.

If it is difficult to secure the object, if inexperienced operators are using the machine, and in similar situations, we recommend that you configure the **[Operation before Printing]** setting to check the height of the object before printing. Note, however, that enabling this setting increases the time before printing starts. Configure this setting appropriately according to the level of user experience and the secured state of the object.

### Procedure

1. On the Utility home screen, click .
2. Click [Preferences].
3. Select the [Check Media Height before Starting Printing] check box.
4. Click [Apply] to confirm your entry.
5. Click [Close] to return to the original screen.

#### MEMO

- Default setting: Cleared

\*1 When there is no [Flat Table Lowering Amount] setting

# System Settings

## Changing the Units of Measurement

Set the units displayed in Utility.

### Procedure

1. On the Utility home screen, click .
2. Click [System Information].
3. In [Units], set [Length] and [Temperature].
4. Click [Apply] to confirm your entry.
5. Click [Close] to return to the original screen.

Changes to the display unit settings are applied when you restart Utility.

#### MEMO

- Default settings
  - [Length]: mm
  - [Temperature]: °C

#### RELATED LINKS

- [P. 35 Starting/Exiting Utility](#)

## Viewing Printer Information

This is a method for viewing information of this machine, such as serial number and ink type.

### MEMO

You can set the [Nickname] with Roland DG Connect.

### Procedure

1. On the Utility home screen, click .
2. Click [System Information] and check [Machine Information].  
You can check the following information:
  - [Model]: Model name
  - [Nickname]: Nickname of the machine
  - [Serial Number]: Serial number of the machine
  - [Ink Type]: Ink type
  - [Firmware Version]
  - [MAC Address]
3. Click [Close] to return to the original screen.



---

## Viewing Network Information

Use the following procedure to view network information such as the IP address and default gateway.

### Procedure

1. On the Utility home screen, click .

2. Click [System Information] and check [Network].

You can check the following information:

- [Obtain IP Address Automatically]: Enables/disables the automatic obtaining of IP addresses via DHCP.
- [IP Address]
- [Subnet Mask]
- [Default Gateway]

3. Click [Close] to return to the original screen.

#### MEMO

- For information on how to set up a network, refer to [Changing the Network Settings](#).

---

## Checking the Utility Version

The most recent version of Utility is continually used via Roland DG Connect. Check the version of Utility when necessary in cases such as network trouble.

### Procedure

1. On the Utility home screen, click .
2. Click [System Information] and check [Version].  
You can check the version of Utility here.

---

## Changing the Network Settings

This section explains how to configure the settings when using the machine with a fixed IP address.

### Step 1: Determine the network addresses.

---

The settings listed here are only an example. The procedure and settings given in this manual do not match every environment. In an environment where the computer being used is connected to multiple network devices and the Internet, inappropriate settings will have a large effect on the entire network. For detailed information about the settings, consult your network administrator.

Determine the IP addresses, subnet mask, and default gateway to connect the computer and this machine to a network.

#### Procedure

**1. Determine the IP addresses.**

- Computer: 192.168.0.XXX
- Device: 192.168.0.YYY

"XXX" and "YYY" represent numbers from 1 to 254. Ensure that they are different from the numbers of other network equipment.

**2. Determine the subnet mask.**

- Computer: 255.255.255.0
- Device: 255.255.255.0

Use the same number for the computer and this machine.

**3. Determine the default gateway.**

- Computer: 192.168.0.AAA
- Device: 192.168.0.AAA

"AAA" represents numbers from 1 to 254. It may not be necessary to set this number, so check with your network administrator.

## Step 2: Change the IP address.

### Procedure

1. On the Utility home screen, click .
2. Click [System Information].
3. Clear the [Obtain IP Address Automatically] check box under [Network].
4. Enter the machine network addresses determined under [Step 1: Determine the network addresses..](#)

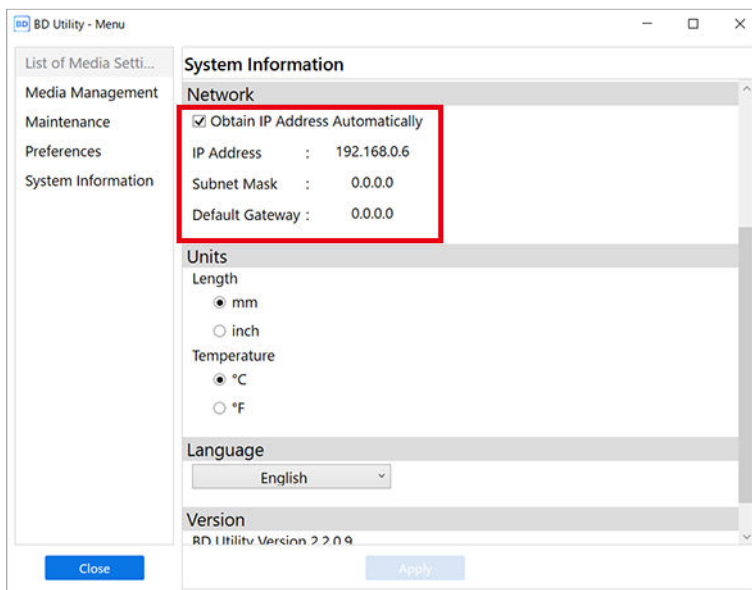

5. Click [Apply].
6. Click [Close] to return to the original screen.
7. Start Roland DG Connect Hub.
8. Click [Settings], and then clear the [Auto printer registration] check box.
9. Click [Settings]>[Printer settings].
10. Click [+], and then enter the IP address determined under [Step 1: Determine the network addresses.](#) in the address field.
11. Click [Verify], and then click [Apply].
12. Click [OK].

#### MEMO

If it is not possible to connect the computer and the machine during reinstallation (such as when relocating a machine with a fixed IP address), press the reset button to switch to automatic IP address acquisition.

1. Switch off the sub power.
2. Use a paper clip or something similar to hold down the reset button (A) for 5 seconds or longer.  
You will hear a short beep when you press the reset button. If you hold down this button for at least 5 seconds from this point, you will hear two short beeps and the machine will reset.

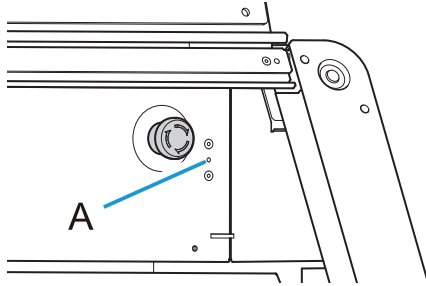

## Step 3: Setting the Computer's Network

### Procedure

1. Log on to Windows as the [Administrator] or a member of the [Administrators] group.
2. Display the network connections screen.
  - Windows 11
    - a. Click [Start]>[Settings].
    - b. Click [Network & Internet]>[Dial-up].
    - c. Click [Network and Sharing Center].
    - d. Click [Ethernet] or [Wi-Fi].
  - Windows 10
    - a. Click [Start]>[Settings]>[Network & Internet].
    - b. Click [Network and Sharing Center].
    - c. Click [Ethernet] or [Wi-Fi].
3. Click [Properties].  
If a [User Account Control] window appears, click [Continue].

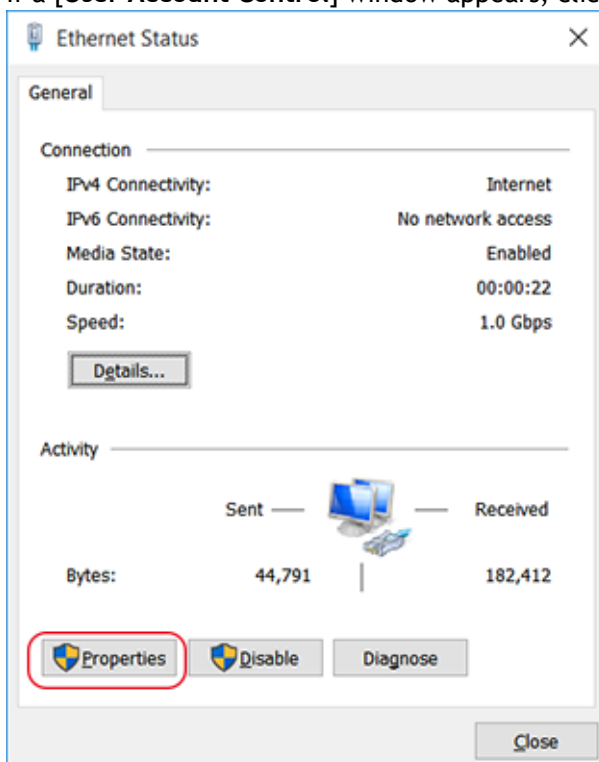

The [Ethernet Properties] or [Wi-Fi Properties] window appears.

4. Select [Internet Protocol Version 4 (TCP/IPv4) Properties], and then click [Properties].  
If the [Internet Protocol] check box is clear, select it.

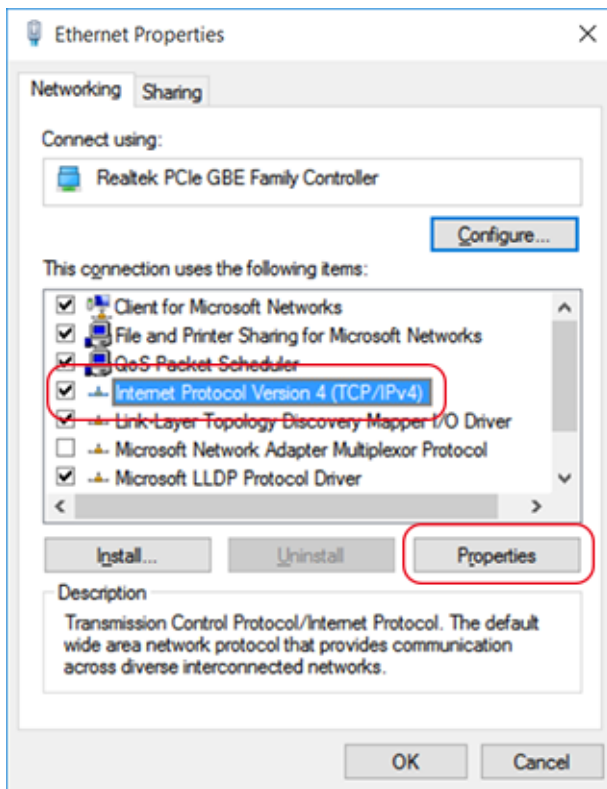

5. Select [Use the following IP address] and enter the computer network address that was determined in Step 1: Determine the network addresses..

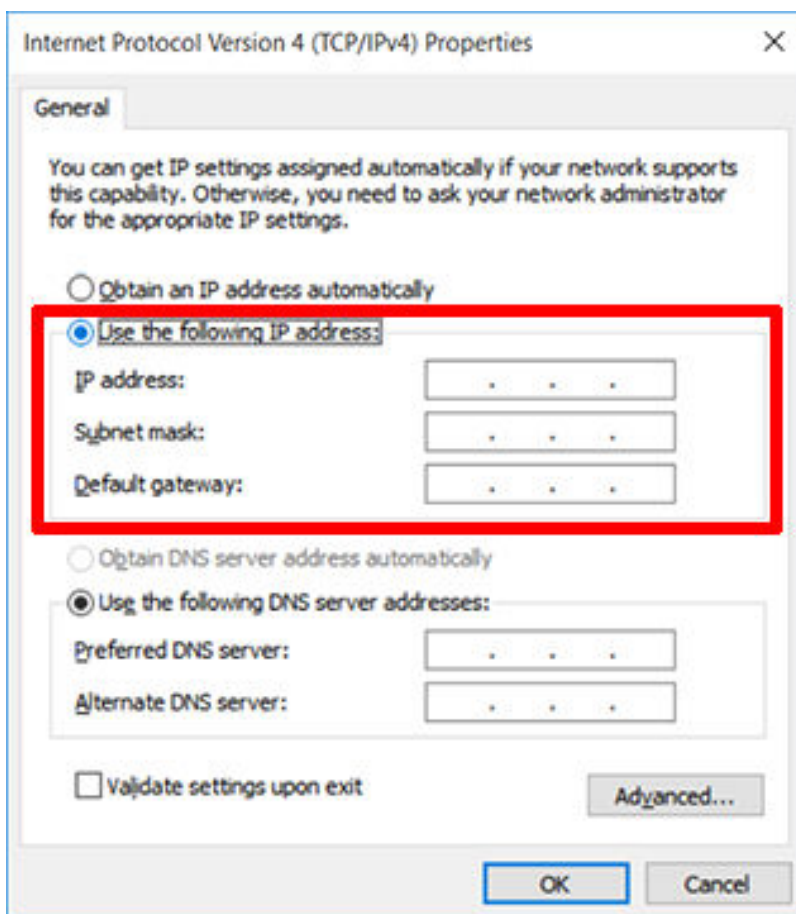

6. Click [OK].
7. Close all the windows opened for the network settings.



---

## Step 4: Configure the FlexiDESIGNER settings.

---

### Procedure

1. Open Roland DG Connect Hub.
2. Select the machine to connect to, and then click [Open] next to [VersaWorks 6].
3. Set the machine to connect to FlexiDESIGNER.

VersaWorks will automatically search for and register the connectable printers. However, if the search finds zero printers or five or more printers, you will have to register printers manually.

- **When the detected number of printers is one to four**

- a. Check the detected printer(s) and click [OK].
- b. When the message [Do you want to install the virtual printer driver?] is displayed, click [Yes].

This message does not indicate the printer driver to use in communication. It indicates the virtual printer driver to use when printing directly from the application.

- c. When the [User Account Control] window appears, click [Yes] (or [Allow]).
- d. When the [Add Printer Wizard] window appears, click [Continue].

Registration is complete once the machine information is displayed in the top menu.

- **When no printers or five or more printers are detected**

- a. Enter the IP address of the printer and click [Verify].

Items such as the [Model Name] and [Firmware Version] are displayed.

**MEMO**

If the printer is not displayed, check the LAN cable connection status.

- b. Set the [Nickname].

If you do not set a nickname, the model name is displayed.

- c. Click [Apply].

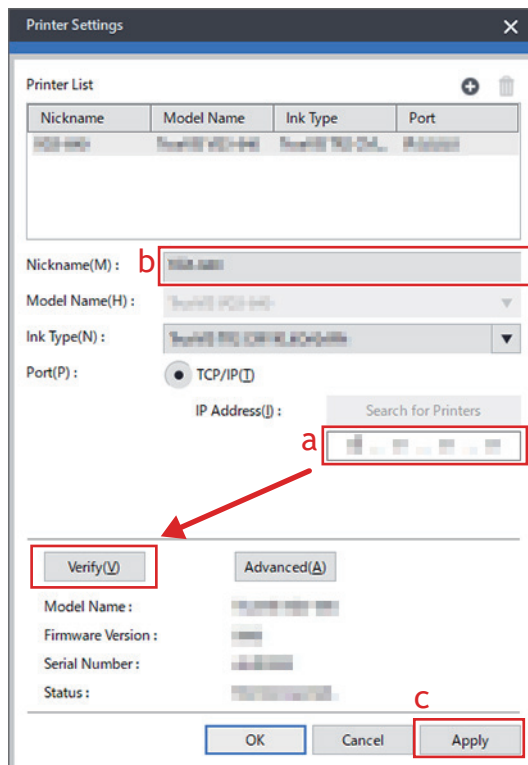

- d. When the message [Do you want to install the virtual printer driver?] is displayed, click [Yes].

This message does not indicate the printer driver to use in communication. It indicates the virtual printer driver to use when printing directly from the application.

- e. When the [User Account Control] window appears, click [Yes] (or [Allow]).  
 f. When the [Add Printer Wizard] window appears, click [Continue].

The information of the connected printer appears in the [Printer List].

- g. Click [OK].

Registration is complete once the machine information is displayed in the top menu.

# Maintenance

# Introduction

---

Important Notes on Handling and Use .....	156
Printer Unit.....	156
Ink Cartridges .....	156
Basic Maintenance Knowledge .....	157
Automatic Maintenance Feature and Notes .....	157
Types and Timing of Maintenance .....	158
When Not in Use for a Prolonged Period.....	159
Action Taken When Dot Drop-out or Dot Displacement Occur .....	160
Action Taken When Uneven Color Issues Occur (White Ink) .....	161

# Important Notes on Handling and Use

This machine is a precision device. To ensure the full performance of this machine, be sure to observe the following important points. Failure to observe them may not only result in loss of performance, but may also cause malfunction or breakdown.

## Printer Unit

- **This machine is a precision device.**
  - Never subject the machine to impacts or excessive force.
  - Never needlessly put your hand or fingers inside the cover, the ink-cartridge ports, or other internal areas of the machine.
- **Install in a suitable location.**
  - Install the machine in a location having the specified temperature and relative humidity.
  - Install the machine in a quiet, stable location offering good operating conditions.
- **The print heads and the UV-LED device are delicate devices.**
  - Never needlessly touch or allow the object to be printed on to scrape them. Failure to handle with care may cause damage.
  - The print heads may be damaged if allowed to dry out. The machine prevents desiccation automatically, but improper operation may render this feature inoperative. Operate properly, as specified in this manual.
  - Never leave the machine with an ink cartridge removed. Remaining ink in the printer may harden and clog the print head nozzles.
  - Daily maintenance as well as various types of maintenance depending on the status must be performed. Read this manual thoroughly and perform the appropriate maintenance at the appropriate times.
  - The print heads are components that wear out. Periodic replacement is required, with the frequency of replacement depending on use.

## Ink Cartridges

- **Ink cartridges come in various types.**
  - Use a type that is compatible with the printer. Also, be sure to use only genuine items from Roland DG Corporation.
- **Never subject ink cartridges to impacts and never attempt to disassemble ink pouches.**
  - Never drop the ink cartridges or shake them forcefully. The impact may rupture the internal pouches and cause the ink to leak.
  - Never attempt to disassemble.
  - Never attempt to refill the ink.
  - If ink gets on your hands or clothing, wash it off as soon as possible. Removal may become difficult if allowed to stand.
- **Storage**
  - Use up the ink before the expiration date printed on the ink cartridge.
  - Store the ink cartridge in a location that is not subject to direct sunlight or strong illumination.
  - Store the ink cartridges unopened in a well-ventilated location at a temperature of 5°C (41°F) or higher and less than 40°C (104°F) and a relative humidity of 20% RH to 80% RH.

# Basic Maintenance Knowledge

## Automatic Maintenance Feature and Notes

This machine has a feature that automatically performs maintenance periodically. This feature performs operations such as ones that prevent the print heads from drying out, so:

- Always keep the main power switched on.
- Do not use the machine with one or more covers open.
- Never leave the machine with an ink cartridge removed.
- Never leave the machine with an empty ink cartridge.
- Keep track of the amount of discharged fluid.

### IMPORTANT

During repairs, part replacements, and similar work, never perform any operations that are not written in the user's manual. Be sure to contact your authorized dealer.

### IMPORTANT

Dispose of drain packs, used cleaning sticks, replacement parts (wipers, felt wipers, cap tops, filters for deodorizers), and cloths with discharged fluid or ink on them properly in accordance with the laws in effect in your area. Discharged fluid is flammable and contains toxic ingredients. Never attempt to incinerate discharged fluid or cloths with discharge fluid adhere to them, or discard it with ordinary trash. Also, do not dispose of discharged fluid in sewer systems, rivers, or streams. Doing so may have an adverse impact on the environment.

## Types and Timing of Maintenance

To use this machine under its optimal conditions, it is important to perform the appropriate maintenance at the appropriate times.

### Regular Maintenance

These are the maintenance items that are required on a daily or periodic basis.

Timing	Item	Refer to
Before work	Mixing ink cartridges (white ink)	<a href="#">P. 163 Maintenance of Ink Cartridges</a>
	Checking and cleaning the print heads	<a href="#">P. 64 Performing a Nozzle Drop-out Test</a> <a href="#">P. 66 Performing Normal Cleaning</a>
After work	Cleaning the machine	<a href="#">P. 164 Cleaning the Machine</a>
When a message appears	Manual cleaning	<a href="#">P. 168 Manual Cleaning Method</a>
	Cleaning the UV-LED device	<a href="#">P. 174 Cleaning the UV-LED devices</a>

### Advanced Maintenance

This is maintenance that is performed when problems occur. Some of this maintenance also consumes a large amount of ink, so thoroughly read the explanation, and then perform the operation at the appropriate point in time.

Timing	Item	Refer to
When dot drop-out or dot displacement occurs	Each type of cleaning through ink renewal	<a href="#">P. 160 Action Taken When Dot Drop-out or Dot Displacement Occur</a>
When uneven color issues occur (white ink)	Ink mixing through each type of cleaning	<a href="#">P. 161 Action Taken When Uneven Color Issues Occur (White Ink)</a>

### Replacing Consumable Parts

These items are for replacement of consumable parts. Thoroughly read the explanation, and then perform the operation at the appropriate point in time.

Timing	Item	Refer to
When a message appears	Drain pack	<a href="#">P. 188 Replacing the Drain Pack</a>
	Wiper	<a href="#">P. 192 Replacing the Wiper</a>
	Felt wiper	<a href="#">P. 194 Replacing the Felt Wiper</a>
	Cap top	<a href="#">P. 196 Replacing the Cap Top</a>
Every year or when an odor is noticed in the vicinity of the machine	Deodorizer filter	<a href="#">P. 202 Replacing the Deodorizer Filter</a>

## When Not in Use for a Prolonged Period

**In advance, insert ink cartridges that have a large amount of ink remaining.**

If the ink runs out, the machine will not be able to periodically perform automatic maintenance. If the machine is left in this state, the print heads may malfunction. If you know that you will not use the machine for a prolonged period, insert ink cartridges that have a large amount of ink remaining.

**Switch the sub power on once every two weeks.**

Switch the sub power on once every two weeks. When you turn on the power, the machine automatically performs operations such as those to keep the print heads from drying out. Leaving the machine unused for a prolonged period may damage the print heads, so be sure to switch on the power to perform these automatic operations.

**Keep the machine at a constant temperature and relative humidity.**

Even when the machine is not in use, keep it at a temperature of 5 to 40°C (41 to 104°F) and a relative humidity of 20 to 80% (with no condensation). Failure to do so may result in malfunction.

**Discharged fluid will increase even when the sub power is off.**

Maintenance work is performed even when the sub power is off. Generally speaking, it takes about 11 months from the time the drain pack is new for the discharged fluid to fill up. For information about purchasing drain packs, contact your authorized dealer.

### IMPORTANT

Do not reuse drain packs. Doing so makes it impossible to manage the amount of discharged fluid, which may overflow.

### RELATED LINKS

- [P. 188 Replacing the Drain Pack](#)



## Action Taken When Dot Drop-out or Dot Displacement Occur

This is the procedure for taking action when there is dot drop-out or dot displacement. A large amount of ink is consumed in some operations. Also, because the print heads themselves are prone to damage, do not perform such operations more than necessary.

### Procedure

**1. Perform Normal Cleaning.**

If the issue does not resolve after performing this operation two or three times, proceed to the next step.

**2. Perform Medium Cleaning.**

If the issue does not resolve after performing this operation two or three times, proceed to the next step.

**3. Perform Powerful Cleaning.**

If the issue does not resolve after performing this operation two or three times, proceed to the next step.

**4. Perform Manual Cleaning.**

If the issue does not resolve after performing this operation one time, proceed to the next step.

**5. Perform Ink Renewal.**

If Ink Renewal fails to resolve the issue, contact your authorized dealer.

## Action Taken When Uneven Color Issues Occur (White Ink)

This is the procedure for taking action when color unevenness occurs for white ink. A large amount of ink is consumed in some operations. Also, because the print heads themselves are prone to damage, do not perform such operations more than necessary.

### Procedure

**1. Perform [Maintenance of Ink Cartridges](#).**

Proceed to the next step if the issue is not resolved even after thoroughly mixing the ink cartridge.

**2. Perform [\[Ink Circulation\]](#).**

(1) On the Utility home screen, click .

(2) Click [\[Execute\]](#) under [\[Maintenance\]>\[Ink Circulation\]](#).

The ink in the ink paths is circulated. If the issue does not resolve after performing this operation one time, proceed to the next step.

**3. Perform [Powerful Cleaning](#).**

If the issue does not resolve after performing ink circulation two or three times, proceed to the next step.

**4. Perform [Ink Renewal](#).**

If the issue does not resolve after performing this operation one time, proceed to the next step.

**5. Perform [Medium Cleaning](#).**

If the issue does not resolve after performing ink circulation two or three times, contact your authorized dealer.

# Regular Maintenance

---

Daily or Periodic Maintenance .....	163
Maintenance of Ink Cartridges .....	163
Cleaning the Machine.....	164
Normal Cleaning.....	165
Manual Cleaning .....	167
Cleaning the UV-LED devices .....	174

# Daily or Periodic Maintenance

## Maintenance of Ink Cartridges

The precipitation of the ingredients in the ink disables printing in normal color. So that the ink mixes well, pull out the ink cartridge, and shake the ink cartridge 50 times (about 20 seconds) horizontally with a stroke length of around 5 cm (1.97 in.) from each end of the ink cartridge before reinserting it.

Shake the ink cartridges:

- All inks: When replaced with a new product.
- White ink: Each day (before starting the day's operations).

The ingredients of white ink have a tendency to separate and settle. Each day, before starting the day's operations, be sure to shake this cartridge. Allowing the ink to stand can cause the settled material to harden, resulting in malfunctions or other problems.

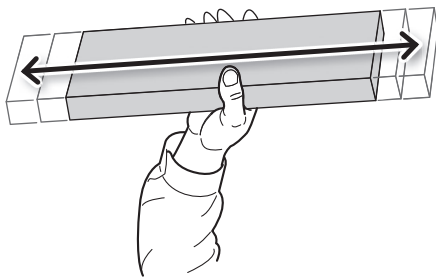

### IMPORTANT

- Before shaking the ink cartridge, wipe off any ink from around its mouth. If you do not wipe off the ink, it may splatter when you shake the ink cartridge.
- When you have finished shaking the ink cartridge, immediately reinstall the ink cartridge. Taking time to reattach the ink cartridge will adversely affect the ink path.
- Even if you are not using the printer, shake the white ink cartridge 50 times (about 20 seconds) once a week.

## Cleaning the Machine

Wipe away any buildup of dust, dirt, or any ink or grime that has adhered to the interior of the machine as part of daily cleaning.

**⚠ WARNING**

**Never use gasoline, thinner, or any other flammable material.**  
Doing so may cause a fire.

**MEMO**

- This machine is a precision device and is sensitive to dust and dirt. Perform cleaning on a daily basis.
- Never attempt to oil or lubricate the machine.
- Before performing this operation, remove any objects to be printed on.

### Procedure

1. **Open the front cover.**  
Remove any objects or jigs that are on the flat table.
2. **Clean the locations shown in the following figure.**

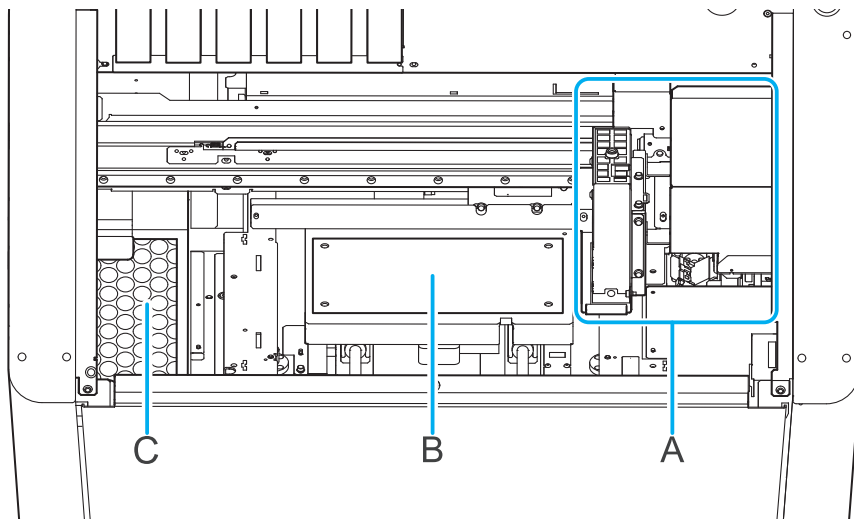

A	UV-LED device, print-head carriage surface	Clean by wiping with a cloth moistened by neutral detergent diluted with water then wrung dry or a soft, dry cloth.
B	Vicinity of the flat table	
C	Vicinity of the deodorizer	

**MEMO**

If dust and dirt accumulate in the machine, they are likely to affix to the object.

3. **When you have finished cleaning, close the front cover.**

## Normal Cleaning

### Procedure

1. Set up the nozzle drop-out test paper.  
P. 31 Registering and Setting Up the Nozzle Drop-out Test Paper

2. Click  [Cleaning] on the Utility home screen.

3. Select [Normal Cleaning] under [Head Cleaning], and then click [Execute].

[Cleaning in progress.] and an estimate for the remaining cleaning time are displayed on the Utility home screen.

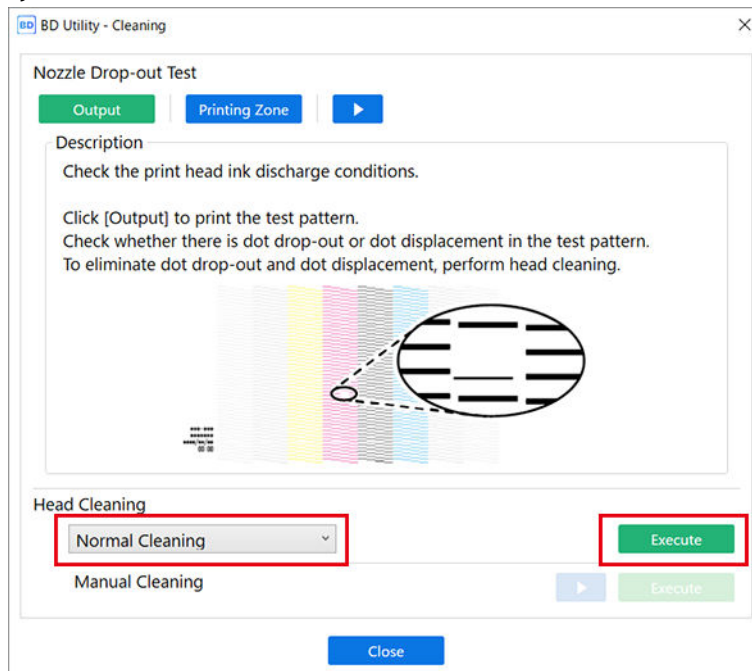

4. Click [Output] under [Nozzle Drop-out Test].

Printing of the test pattern starts.

5. When printing is complete, open the front cover.

6. Check whether there is dot drop-out or dot displacement in the test pattern.

Missing blocks indicate dot drop-out. Collapsed or inclined blocks indicate dot displacement.

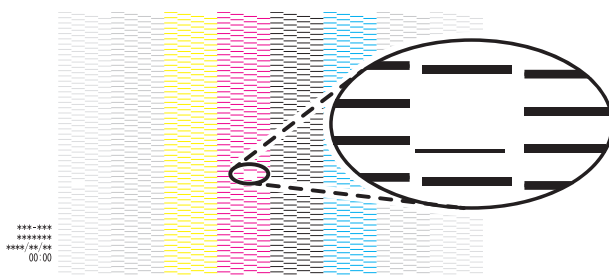

MEMO

- If the problem persists, try performing normal cleaning again.
- If problems such as dot drop-out and dot displacement persist even after you have performed normal cleaning several times, use a different cleaning method.

[P. 160 Action Taken When Dot Drop-out or Dot Displacement Occur](#)

**7. Close the front cover.**

If no dot drop-out or dot displacement occurs, preparations for output are finished.

**8. Click [Close] to return to the original screen.**

## Manual Cleaning

### When Manual Cleaning Is Necessary

#### When the Following Symptoms Occur

It is recommended to perform manual cleaning when any of the symptoms given below occur and cannot be solved by the processes from normal cleaning through powerful cleaning.

Wiper replacement may also be effective in improving these symptoms.

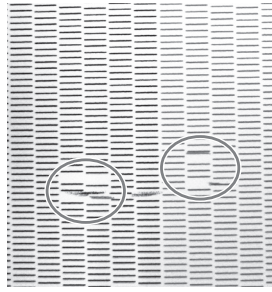
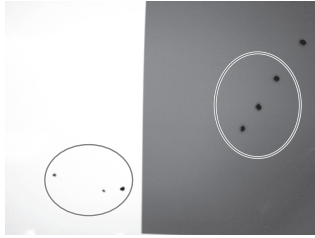
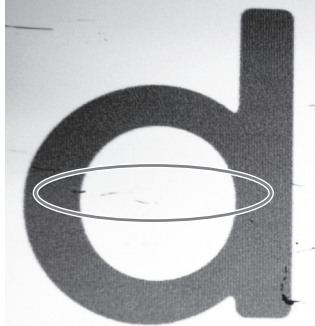
Dot drop-out or dot displacement	Ink drips	Dragging dirt
		
<p>Dust or other foreign matter adheres to the print heads and impedes correct ink discharge.</p>	<p>Ink pools in dust or dirt adhered to the print heads, and drips onto the media.</p>	<p>The phenomenon where dirt or dust accumulates on the print heads.</p>

#### MEMO

- If you use up the cleaning sticks and cleaning liquid used for manual cleaning, contact your authorized dealer.
- The print heads are consumable parts and will need to be replaced depending on the frequency of use or usage conditions.

#### RELATED LINKS

- [P. 192 Replacing the Wiper](#)



## Manual Cleaning Method

For manual cleaning, use the manual cleaning tool to automatically clean the print heads. Following this, manually clean the wiper, scraper, and area around the cap top.

### ⚠ WARNING

**Be sure to perform operations as specified by the instructions, and never touch any area not specified in the instructions.**

Sudden movement of the machine may cause injury.

### IMPORTANT

#### Important notes on this procedure



- To prevent the print heads from drying out, finish the manual cleaning within 10 minutes after the automatic cleaning. A warning beep sounds after 10 minutes.
- Never use any implements other than the included cleaning sticks. Cotton swabs or other lint-producing items may damage the print heads. If you use up the cleaning sticks, contact your authorized dealer.
- Use a new cleaning stick per cleaning session. Reusing cleaning sticks may reduce print quality.
- Do not put a cleaning stick that has been used for cleaning into the cleaning liquid. Doing so will deteriorate the cleaning liquid.
- Stroke the sponges very gently, applying as little pressure as possible. Never rub, scrape, or crush them.

#### When a warning beep sounds during cleaning

To prevent the print heads from drying out, an alarm sounds about 10 minutes after automatic cleaning finishes. Perform the operation by following the message displayed in Utility.

**Do not use a manual cleaning tool that may have been deformed by striking or dropping it. Instead, replace it before cleaning.**

Using a deformed manual cleaning tool may prevent manual cleaning from being carried out properly or damage the machine.

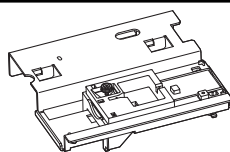
Required items		
		
Cleaning sticks	Cleaning liquid	Manual cleaning tool



### MEMO

Use the following link to view a reference video for this procedure. We recommend that you view this video to understand the overall flow of work.

<https://youtu.be/VmDmhUXBdNA>

## Procedure

1. Remove the object to be printed on.
2. If the manual cleaning tool is stored inside the unit, take it out.
3. Close the front cover.
4. Access the manual cleaning menu using one of the following methods.

- Notifications: Click , and then click  for [The time for manual cleaning has arrived.].
- Click  [Cleaning] on the Utility home screen, then click [Execute] for [Manual Cleaning].

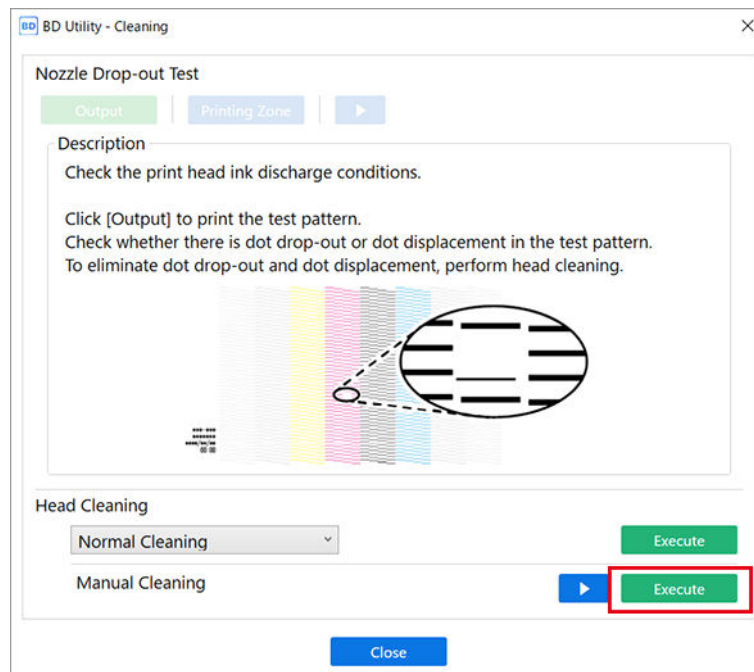
**MEMO**

The manual cleaning work procedure is displayed in Utility. Carefully read the on-screen instructions and carry out the work.

- 5. Wear protective gear (gloves and glasses).**  
Put on the protective equipment, and then click [Next] in Utility.
- 6. Prepare a manual cleaning tool.**
  - (1) Apply a large amount of cleaning liquid to the cleaning stick.

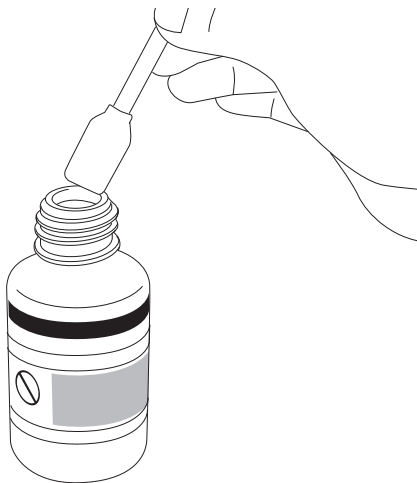

- (2) **Attach the cleaning stick to the manual cleaning tool.**  
Push in the cleaning stick as far as it will go.

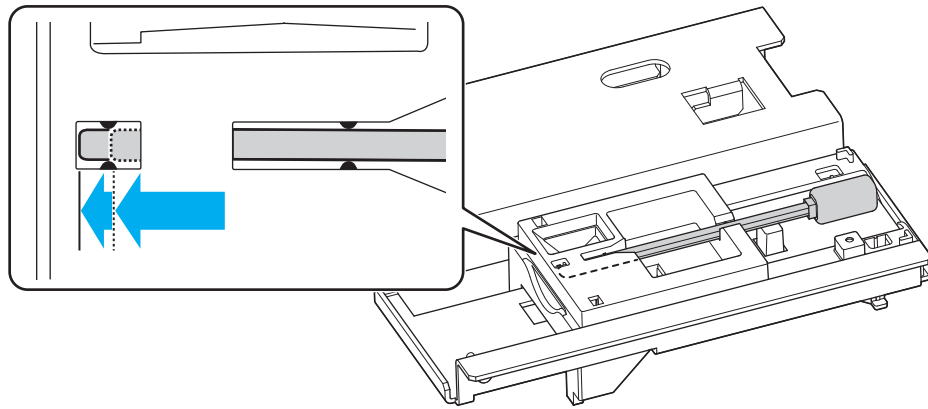

After installing the cleaning stick, click **[Next]** in Utility.

7. Open the front cover.

8. Use the manual cleaning tool retaining screw to secure the manual cleaning tool in the position shown in the figure.

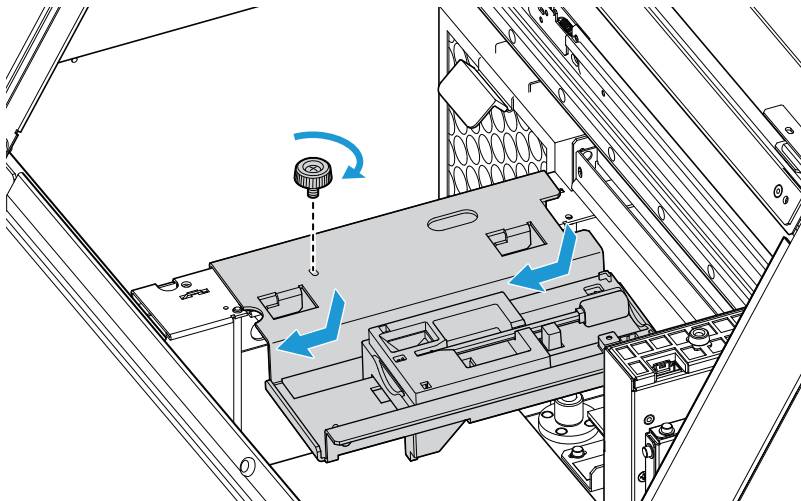

9. Close the front cover.

After closing the front cover, click **[Next]** in Utility.

Perform automatic cleaning near the print heads.

10. When **[Automatic cleaning has finished.]** is displayed in Utility, open the front cover and remove the manual cleaning tool.

- Use the cleaning stick to clean the wiper, scraper, and cap top after cleaning the print heads.
- It is recommended that you store the manual cleaning tool in front of the deodorizer.

**IMPORTANT**

Store the manual cleaning tool fixing screw so that you do not lose it.

11. Close the front cover.

Remove the manual cleaning tool. Close the front cover, and then click **[Next]** in Utility.

The print-head carriage will move to the left.

12. Open the front cover.

**13.** Follow the guidelines below to clean the wiper, scraper, and cap top.

- (1) Remove the cleaning stick from the manual cleaning tool.
- (2) Clean the right side and top of the wiper.

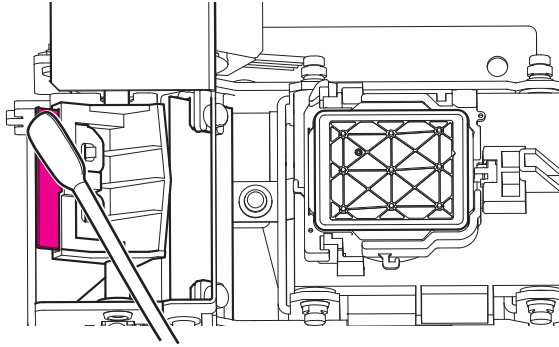

- (3) Clean the scraper.

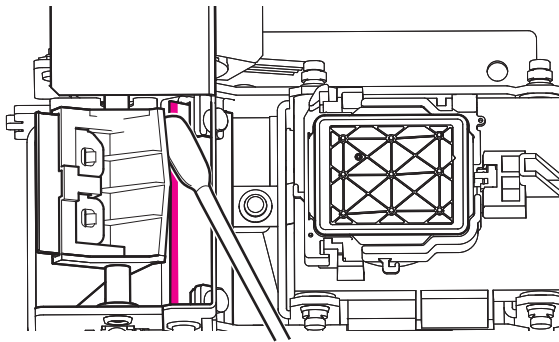

- (4) Clean the four sides around the cap top.

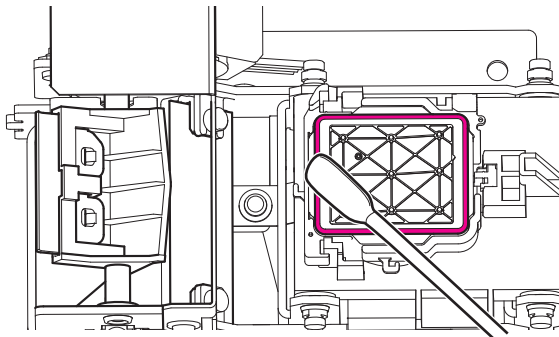

- (5) Use the wide surface of the cleaning stick, and then shift it to a different location, pressing the cleaning stick lightly against the cap top to absorb the dirt there.

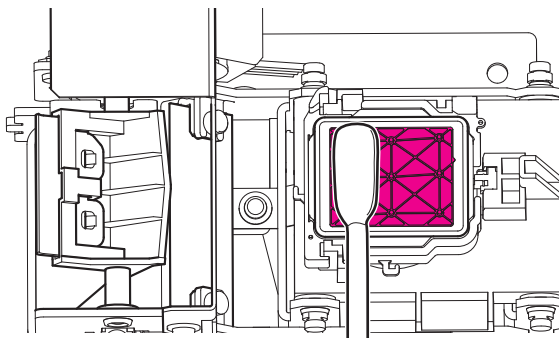

- (6) Close the front cover.

After closing the front cover, click [Next] in Utility.

**14.** When cleaning finishes, click [Close] to return to the original screen.

15. Set up the nozzle drop-out test paper.  
P. 31 Registering and Setting Up the Nozzle Drop-out Test Paper

16. Click  [Cleaning].

17. Click [Output] under [Nozzle Drop-out Test].  
 Printing of the test pattern starts.

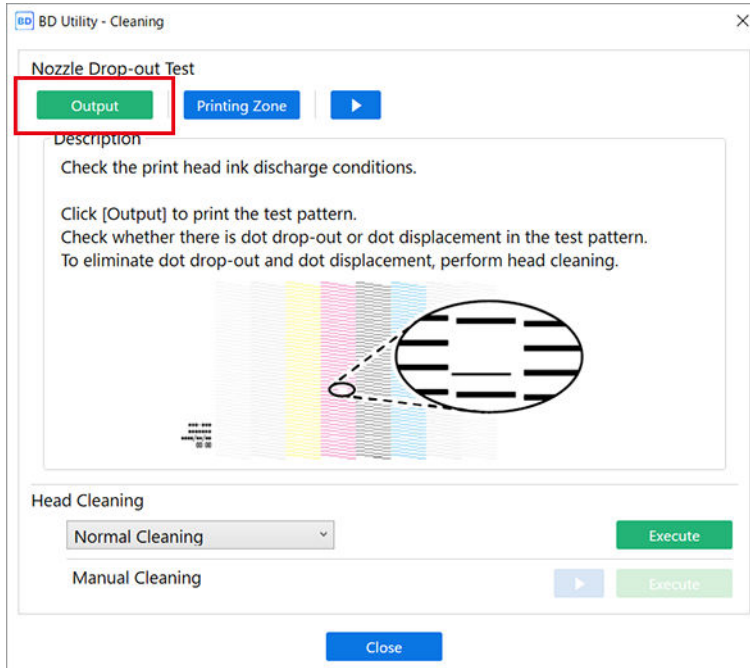

18. When printing is complete, open the front cover.
19. Check whether there is dot drop-out or dot displacement in the test pattern.  
 Missing blocks indicate dot drop-out. Collapsed or inclined blocks indicate dot displacement.

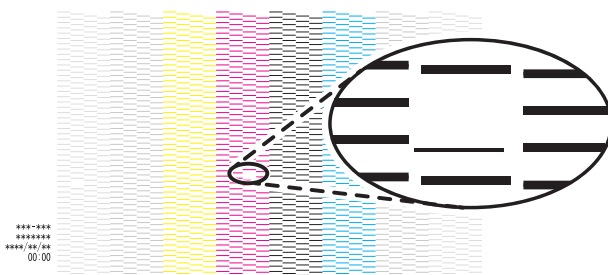

**MEMO**

- If the problem persists, perform manual cleaning again.
- If problems such as dot drop-out and dot displacement persist even after you have performed manual cleaning several times, perform [Ink Renewal].

If no dot drop-out or dot displacement occurs, preparations for output are finished.

20. Click [Close] to return to the original screen.

RELATED LINKS

- [P. 182 Ink Renewal](#)

---

## Cleaning the UV-LED devices

### When UV-LED Device Cleaning Is Necessary

The UV-LED device is an important component for ink adhesion. It requires periodic and appropriate maintenance. It is important to clean the UV-LED device with the appropriate timing.

#### When [The time for manual cleaning of the UV lamp has arrived.] Appears

This tells you when to clean the UV lamps according to usage conditions in order to maintain stable printing conditions at all times. If you receive this notification, be sure to perform UV lamp cleaning.

#### When There Is a Lot of Scattered Ink Mist and the Inside of the Machine is Soiled

Perform this cleaning every day when frequently printing with the print heads at a distance from the print surface or when ink is emitted to locations that protrude from the print surface. If the scattered ink mist is allowed to harden, it may cause malfunctions.

#### When the Irradiation Surfaces of the UV-LED Device Are Dirty (see the following figure)

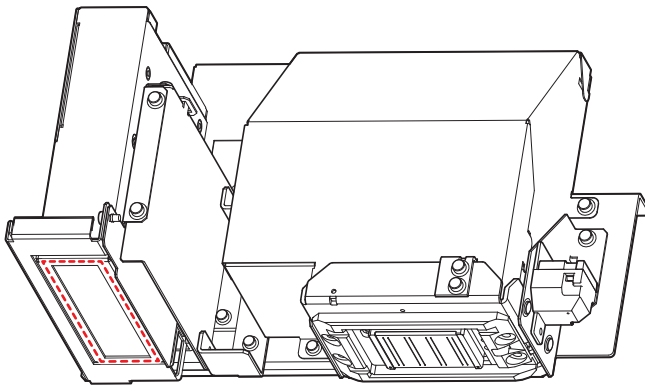

## UV Lamp Manual Cleaning Method

### IMPORTANT

#### Important notes on this procedure

- Before performing this operation, remove any objects to be printed on.
- To prevent the print heads from drying out, finish this procedure in 10 minutes or less. A warning beep sounds after 10 minutes.
- The cloths, alcohol, and similar items used in cleaning are not included with the product.

#### Required items

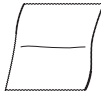
	
Anhydrous ethanol or isopropyl alcohol	Cloth (that is not fluffy)

### ⚠ CAUTION

**Do not perform cleaning immediately after printing has finished. (Wait approximately 15 minutes after printing finishes.)**

The area around the UV-LED device is hot and may cause burns.

### ⚠ CAUTION

**When using anhydrous ethanol or isopropyl alcohol, be sure to follow the product's usage precautions.**

Exercise caution regarding items such as fire, ventilation, and rashes.

### ⚠ CAUTION

**Only use anhydrous ethanol or isopropyl alcohol.**



Using chemicals (or similar substances) other than anhydrous ethanol or isopropyl alcohol may lead to UV-LED device damage.

### ⚠ CAUTION

**Use cloth that is not fluffy to wipe off the parts. Do not use a hard material such as metal.**

Using cloth that is fluffy or a hard material such as metal may lead to UV-LED device damage.

## Procedure

1. Remove the object, and then close the front cover.
2. Access the manual cleaning menu using one of the following methods.
  - Notifications: Click , and then click  for [The time for manual cleaning of the UV lamp has arrived.].



- On the Utility home screen, click , then click [Execute] for [UV Lamp Manual Cleaning] under [Maintenance].

The print-head carriage moves to near the center.

3. Open the front cover, and then remove the maintenance cover.
4. Touch the location shown in the figure (next to the ink slots) to discharge any static electricity.

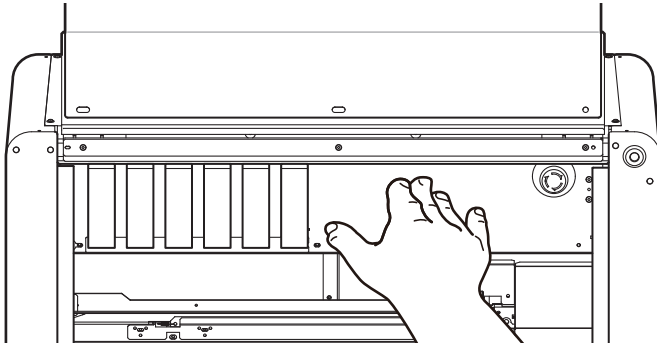

5. Wear protective gear (gloves and glasses).
6. Click [OK].  
The print-head carriage and flat table move.
7. Wet a cloth with anhydrous ethanol or isopropyl alcohol, and then wipe off the irradiation surface of the UV-LED device with this cloth.  
Wipe the cloth across each UV lamp for approximately 10 round trips until all the dirt is cleared away.

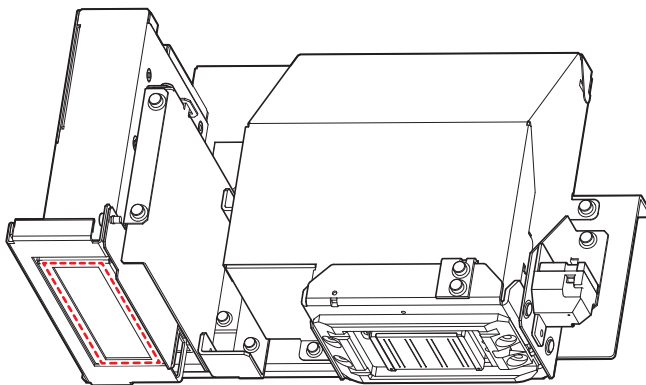

After you have wiped off the dirt, click [Next].

8. Attach the maintenance cover, and then close the front cover.
9. Click [Finish].  
The print-head carriage returns to its original position.

# Advanced Maintenance

---

Maintenance to Perform When Problems Occur .....	178
Medium Cleaning .....	178
Powerful Cleaning .....	180
Ink Renewal .....	182
Ink Discharge.....	183

# Maintenance to Perform When Problems Occur

## Medium Cleaning

When problems such as dot drop-out and dot displacement are not resolved by normal cleaning, perform the more forceful [Medium Cleaning] to remove clogging from the print heads nozzles.

### MEMO

Medium cleaning consumes more ink than normal cleaning. Because the print heads are prone to damage if cleaned too frequently, do not perform cleaning more than necessary.

### Procedure

1. Set up the nozzle drop-out test paper.
2. Click  [Cleaning] on the Utility home screen.
3. Select [Medium Cleaning] for [Head Cleaning], and then click [Execute].  
[Cleaning in progress.] and an estimate for the remaining cleaning time are displayed on the Utility home screen.

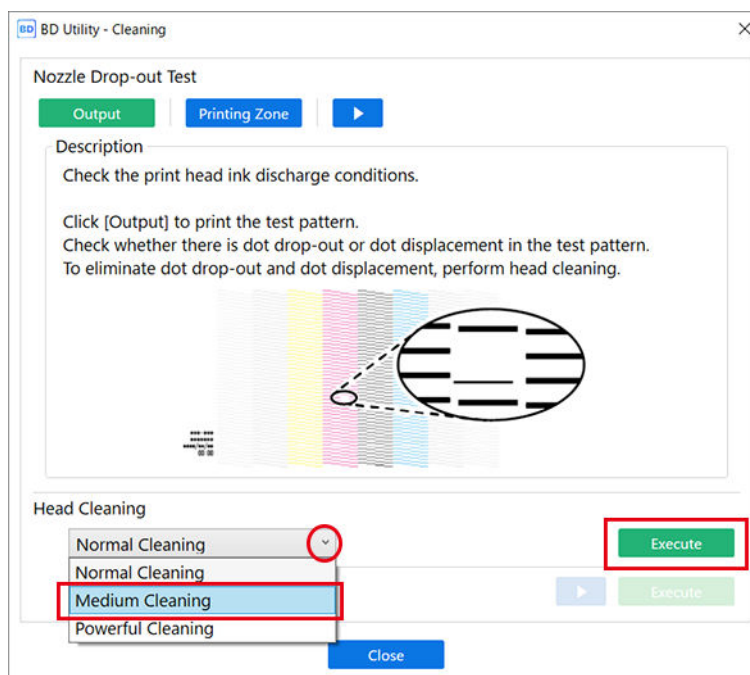

4. Click [Output] under [Nozzle Drop-out Test].  
Printing of the test pattern starts.
5. When printing is complete, open the front cover.
6. Check whether there is dot drop-out or dot displacement in the test pattern.  
Missing blocks indicate dot drop-out. Collapsed or inclined blocks indicate dot displacement.

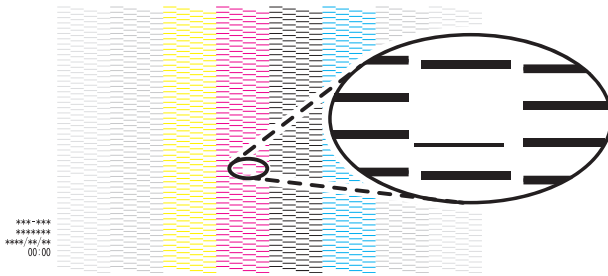
**MEMO**

- If the problem persists, try performing medium cleaning again.
- If problems such as dot drop-out and dot displacement persist even after you have performed medium cleaning two or three times, perform the more forceful **[Powerful Cleaning]**.

If no dot drop-out or dot displacement occurs, preparations for output are finished.

7. Close the front cover.
8. Click **[Close]** to return to the original screen.

**RELATED LINKS**

- [P. 180 Powerful Cleaning](#)

## Powerful Cleaning

When problems such as dot drop-out and dot displacement are not resolved by medium cleaning, perform the more forceful [Powerful Cleaning] to remove clogging from the print head nozzles.

### MEMO

Powerful cleaning consumes more ink than medium cleaning. Because the print heads are prone to damage if cleaned too frequently, do not perform cleaning more than necessary.

### Procedure

1. Set up the nozzle drop-out test paper.
2. Click  [Cleaning] on the Utility home screen.
3. Select [Powerful Cleaning] for [Head Cleaning], and then click [Execute].  
[Cleaning in progress.] and an estimate for the remaining cleaning time are displayed on the Utility home screen.

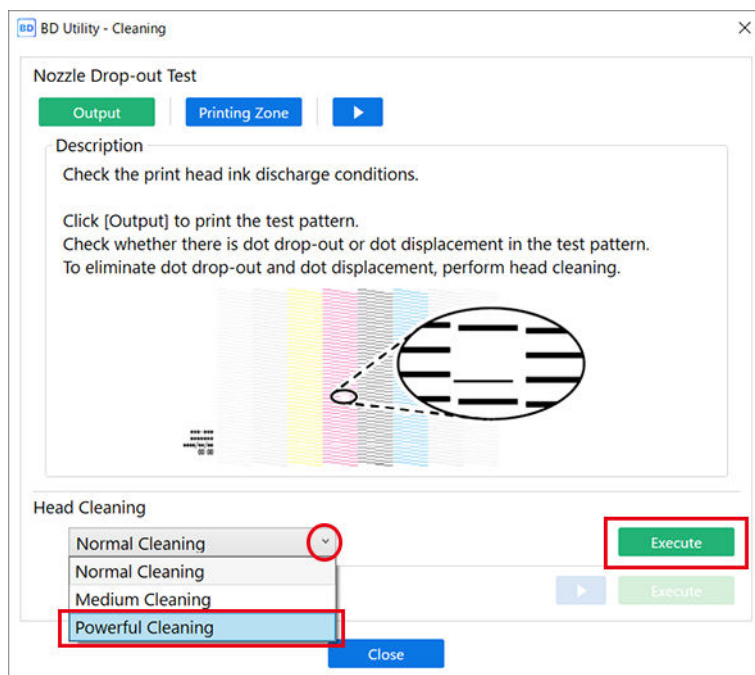

4. Click [Output] under [Nozzle Drop-out Test].  
Printing of the test pattern starts.
5. When printing is complete, open the front cover.
6. Check whether there is dot drop-out or dot displacement in the test pattern.  
Missing blocks indicate dot drop-out. Collapsed or inclined blocks indicate dot displacement.

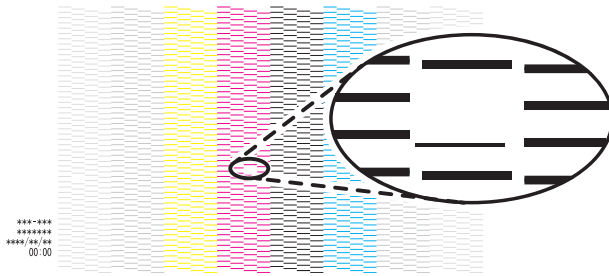
**MEMO**

- If the problem persists, try performing powerful cleaning again.
- If problems such as dot drop-out and dot displacement persist even after you have performed powerful cleaning several times, perform **[Manual Cleaning]**.

If no dot drop-out or dot displacement occurs, preparations for output are finished.

7. Close the front cover.
8. Click **[Close]** to return to the original screen.

**RELATED LINKS**

- [P. 167 Manual Cleaning](#)

## Ink Renewal

This is used to correct dot drop-out or dot displacement, and to restore ink density that cannot be fixed by any means.

### IMPORTANT

To replace the ink in the path, a large amount of ink is consumed and then discharged as discharged fluid. Do not do this frequently.

### Procedure

1. Set up the nozzle drop-out test paper.
2. On the Utility home screen, click .
3. Click [Execute] for [Ink Renewal] under [Maintenance].  
Starts the [Ink Renewal] function.
4. When ink renewal is finished, click [Output] under [Nozzle Drop-out Test].
5. When printing is complete, open the front cover.
6. Check whether there is dot drop-out or dot displacement in the test pattern.  
Missing blocks indicate dot drop-out. Collapsed or inclined blocks indicate dot displacement.

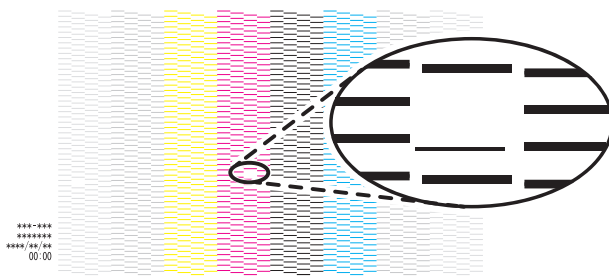

- If no dot drop-out or dot displacement occurs, preparations for output are finished.
- If there still is dot drop-out or dot displacement, contact your authorized dealer.

7. Close the front cover.
8. Click [Close] to return to the original screen.

## Ink Discharge

Perform in advance the ink discharge which is otherwise performed regularly. Perform beforehand in cases when you want to perform printing immediately, such as for a demo.

### MEMO

Because [Ink Discharge] is performed automatically in ordinary maintenance, it is not necessary for the user to execute it.

### Procedure

1. On the Utility home screen, click .
2. Click [Execute] for [Ink Discharge] under [Maintenance].  
Starts the [Ink Discharge] function.



# Replacing Consumable Parts

---

Replacing Ink Cartridges .....	185
Out-of-ink Warnings .....	185
Replacing Ink Cartridges .....	186
Replacing Parts for Maintenance .....	188
Replacing the Drain Pack .....	188
Replacing the Wiper .....	192
Replacing the Felt Wiper .....	194
Replacing the Cap Top .....	196
Replacing the Deodorizer Filter .....	202

# Replacing Ink Cartridges

## Out-of-ink Warnings

When an ink pouch runs out, printing pauses and [Ink Cartridge Error] appears.

When the ink runs out,  is displayed in the Utility home screen, and [Ink has run out.] is displayed in notifications. Replace the empty ink cartridge as soon as possible.

- K: Black
- C: Cyan
- M: Magenta
- Y: Yellow
- Pr: Primer
- Wh: White

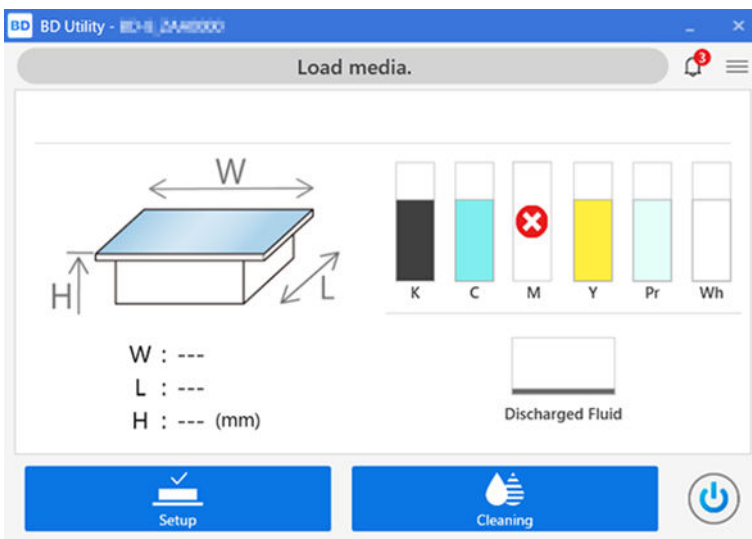

### IMPORTANT

**Never reuse an ink cartridge for which [Ink has run out.] is displayed.**

Even if [Ink has run out.] is displayed, there may be a small amount of ink remaining in the cartridge. Such an ink cartridge is in a state where drawing ink from it is impossible, so using it in such a state may force air into the ink path and cause malfunctions.

## Replacing Ink Cartridges

### ⚠ WARNING

Never store ink, cleaning liquid, or discharged fluid in any of the following locations.

- Any location exposed to open flame
- Any location where high temperature may occur
- Near bleach or any other such oxidizing agent or explosive material
- Any location within the reach of children

Fire may be a danger. Accidental ingestion by children may pose a health hazard.

### IMPORTANT

Important notes on replacing cartridges

- Replace the cartridge with an item of identical type and color.
  - Insert the cartridge so that the side with the arrow faces up.
  - Insert and remove cartridges slowly, one at a time.
  - Insert the cartridge firmly, as far as it will go.
- Never mix different types of items.
- Never leave the machine with an ink cartridge removed. The nozzles of the print heads may become clogged.

### IMPORTANT

Never reuse an ink cartridge for which [Ink has run out.] is displayed.

Even if [Ink has run out.] is displayed, there may be a small amount of ink remaining in the cartridge. Such an ink cartridge is in a state where drawing ink from it is impossible, so using it in such a state may force air into the ink path and cause malfunctions.

## Procedure

1. Open the front cover.
2. Pull out the empty ink cartridge.
3. Gently shake the new ink cartridge.

During storage, the ink components may have precipitated. The precipitation of the ingredients in the ink disables printing in normal color. So that the ink mixes well, shake each ink cartridge 50 times (about 20 seconds) horizontally with a stroke length of around 5 cm (1.97 in.) from each end of the ink cartridge before inserting it.

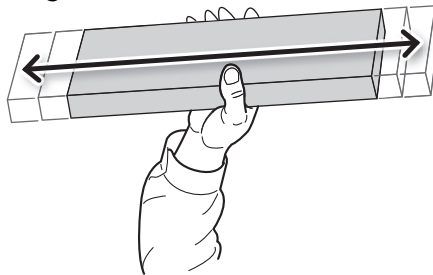

4. Insert the ink cartridge into its ink slot.

Orient the ink cartridge so the arrow or protrusion is on top, and then insert the ink cartridge in the direction shown in the figure as far as it will go.

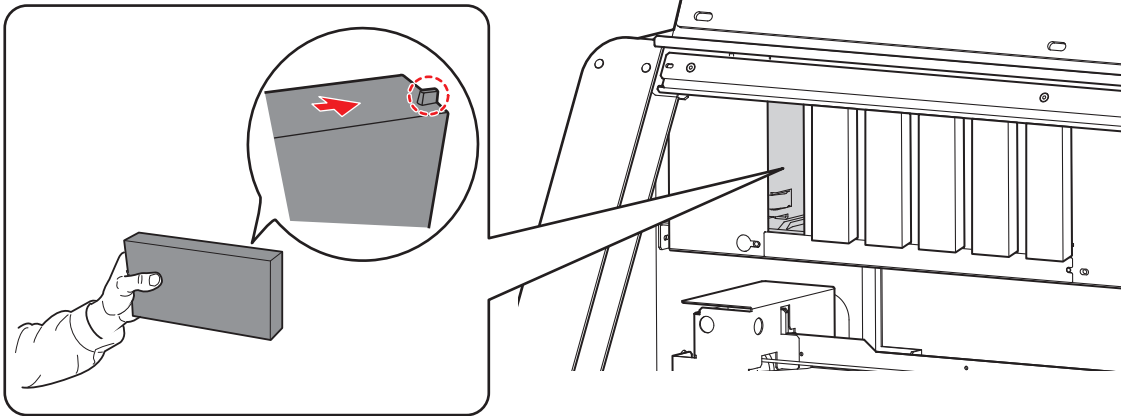

5. Close the front cover.

# Replacing Parts for Maintenance

## Replacing the Drain Pack

Ink left in the print heads after printing or ink used for head cleaning is called discharged fluid. The discharged fluid is collected in a drain pack, and when the specified amount is reached, a replacement message is displayed in Utility.

There are two types of messages for replacing the drain pack. The message displayed depends on the amount of discharged fluid.

1. **[When output, cleaning, and other operations are completed, discard the discharged fluid.]**

At this time, the drain pack has not reached the limit of its use. It can continue to be used if, for example, a replacement drain pack is not readily available. However, the drain pack should be replaced as soon as possible.

2. **[Replace the drain pack.]**

This indicates the usage limit of the drain pack. If this error appears, the drain pack can no longer be used.

The machine is calculating the total amount of discharged fluid. When the amount of discharged fluid reaches near the capacity of the drain pack, the system will issue a message to replace it. If the discharged fluid is not disposed of according to the following procedure, the amount of discharged fluid will not be reset and it will be impossible to control the discharged fluid.

Be sure to replace the drain pack as directed in the displayed message.

Also, if you know that you will not use the machine for a prolonged period, follow the procedure below to replace the drain pack.

### WARNING

**Never place the drain cartridge or ink near an open flame.**

Doing so may cause a fire.

### CAUTION

**Before you remove the drain cartridge, wait for a message to be displayed in Utility.**

Failing to follow this procedure may cause discharged fluid to flow out of the tube and spill, soiling your hands or the floor.

### CAUTION

**When temporarily storing drain packs, you can store them in a sealed container or plastic bag.**

Any spillage or vapor leakage may cause fire, odor, or physical distress.

### IMPORTANT

- **Do not reuse drain packs.**

Doing so makes it impossible to manage the amount of discharged fluid, which may overflow.

- **Dispose of discharged fluid properly, in accordance with the laws in effect in your locale.**

Discharged fluid is flammable and contains toxic ingredients. Never attempt to incinerate discharged fluid or discard it with ordinary trash. Also, do not dispose of it in sewer systems, rivers, or streams. Doing so may have an adverse impact on the environment.

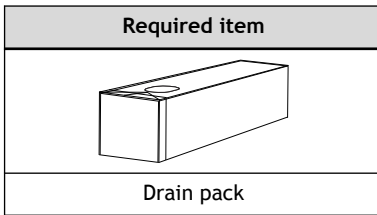

**MEMO**

Use the following link to view a reference video for this procedure. We recommend that you view this video to understand the overall flow of work.

<https://youtu.be/Uw8XZQpKlv8>

**Procedure**

1. Open the front cover, and then remove the maintenance cover.
2. Wear protective gear (gloves and glasses).
3. Remove the drain cartridge.

Pull the drain cartridge out until you can support its base with your hand. Then, remove this cartridge by holding its handle and its base.

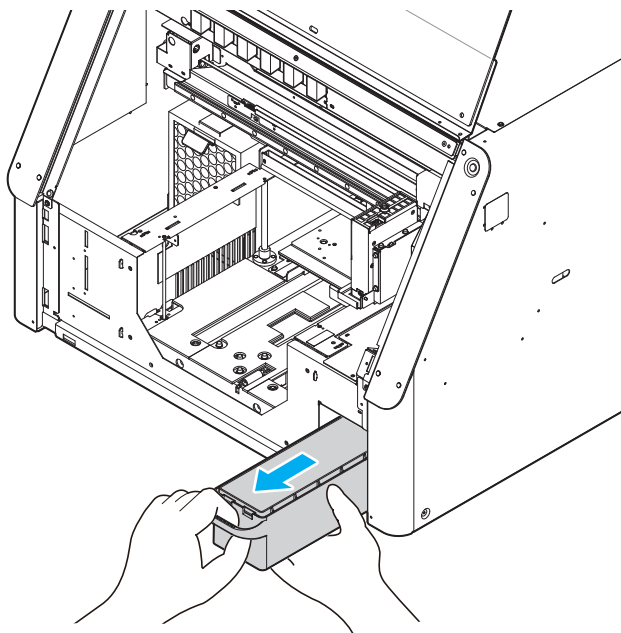

**IMPORTANT**

Do not drop the drain cartridge or subject it to impacts. Damage to the protrusion on the drain cartridge will make it impossible for the machine to recognize the drain cartridge, and the [The drain cartridge was removed.] message will be displayed continuously even when the drain cartridge is installed.

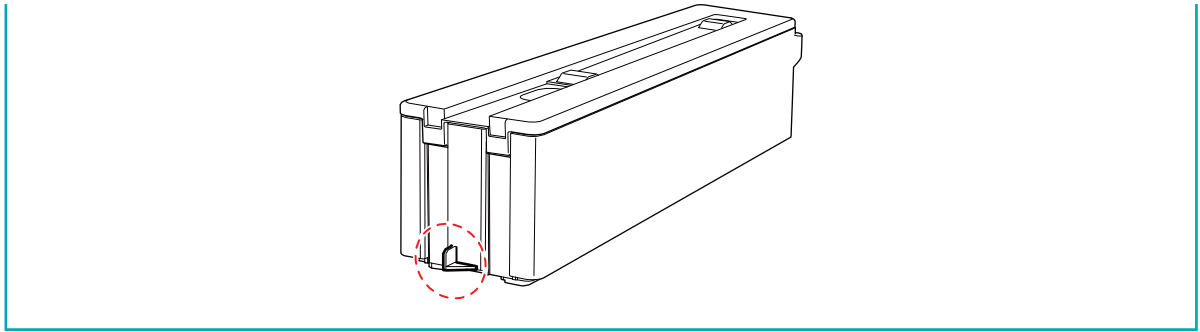

4. Release the hooks in two locations to unlock the drain cartridge lid, and then open it.

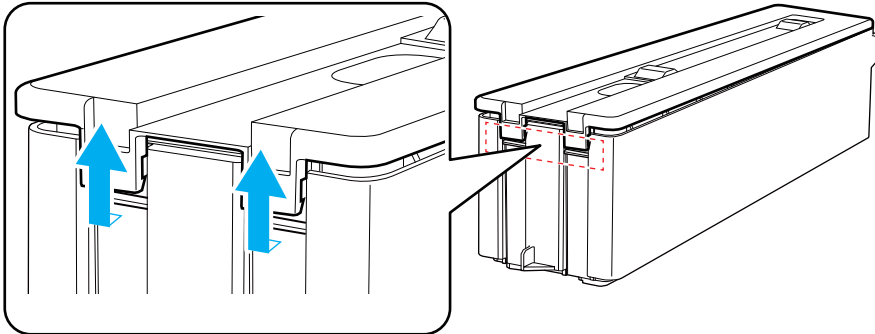

5. Lift up the flap of the drain pack to remove it from the drain cartridge.  
Pull up the drain pack by holding its sides, as pulling it by the flap may tear it.

**MEMO**

Ink adheres when touching the drain pack's hole.

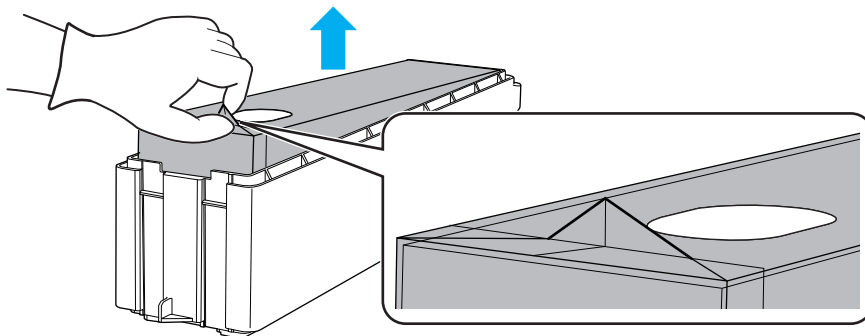

6. Insert a new drain pack into the drain cartridge.  
Insert the drain pack so its hole (B) is on the opposite side to the handle (A) of the drain cartridge.

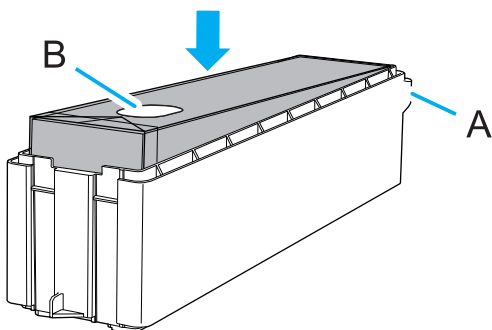

**7. Close the drain cartridge lid.**

Align the hole in the lid of the drain cartridge and the drain pack's hole, and then close the lid from the handle side. If the lid is not flush with the cartridge, gently press down around the circumference of the lid to fit it into the cartridge.

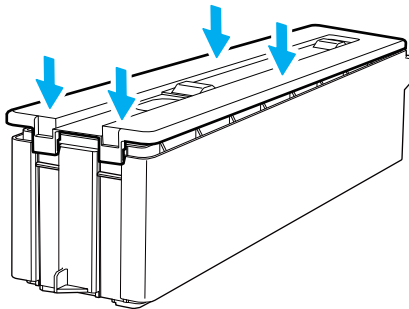

**8. Insert the drain cartridge into the machine.**

Put your hand on the bottom of the drain cartridge and push it in slowly with the horizontal or handle side in a slightly raised state.

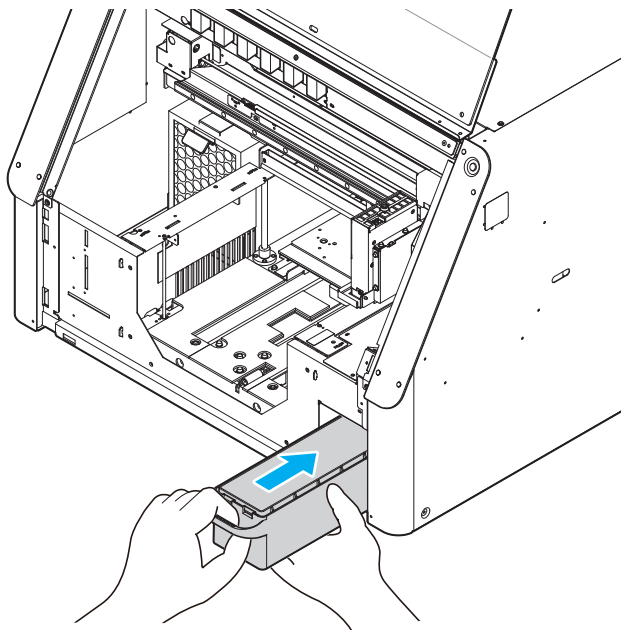

**9. Attach the maintenance cover, and then close the front cover.**

**10. When [Has the drain pack been replaced with a new one?] appears, click [Yes] to close the message.**

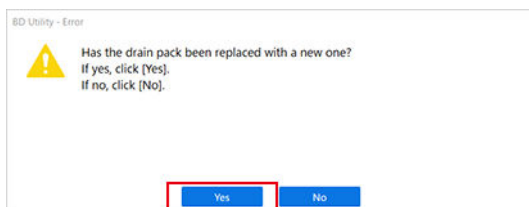

For information about purchasing drain packs, contact your authorized dealer.



## Replacing the Wiper

The wiper is a component that is used for cleaning the print heads.

You will be notified with [The time for wiper replacement has arrived.] when it is time to replace the wiper, so replace it when you are so notified.

For information about purchasing wipers, contact your authorized dealer.

### ⚠ WARNING

**Be sure to perform operations as specified by the instructions, and never touch any area not specified in the instructions.**

Sudden movement of the machine may cause injury.

### IMPORTANT

**When the warning alarm sounds during wiper replacement**

To prevent the print heads from drying out, an alarm sounds about 30 minutes after the start of the operation. Perform the operation by following the message displayed in Utility.

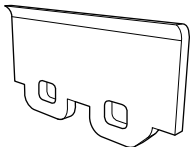
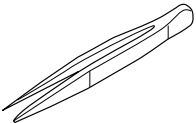

Required items	
	
Wiper	Tweezers

### MEMO

Use the following link to view a reference video for this procedure. We recommend that you view this video to understand the overall flow of work.

<https://youtu.be/JGrvIQDaxfc>

## Procedure

1. Remove the object to be printed on.
2. Click  on the Utility home screen to display the message.
3. Click  under [The time for wiper replacement has arrived.].  
The [Wiper Replacement] window appears.
4. Put on protective equipment (gloves and glasses), and then click [OK].  
The print-head carriage moves to a location where wiper replacement is possible.
5. Follow the on-screen instructions and perform the procedure below to replace the wiper.
  - (1) Open the front cover.
  - (2) Disconnect the hooks (①), and then pull the wiper up and out (②).

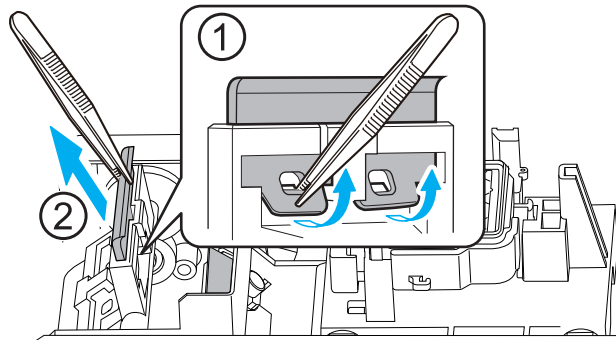

(3) Insert a new wiper as shown in the figure.

Install the wiper so the slanted part with dashed lines is at the back.

(4) Attach the wiper to the hooks.

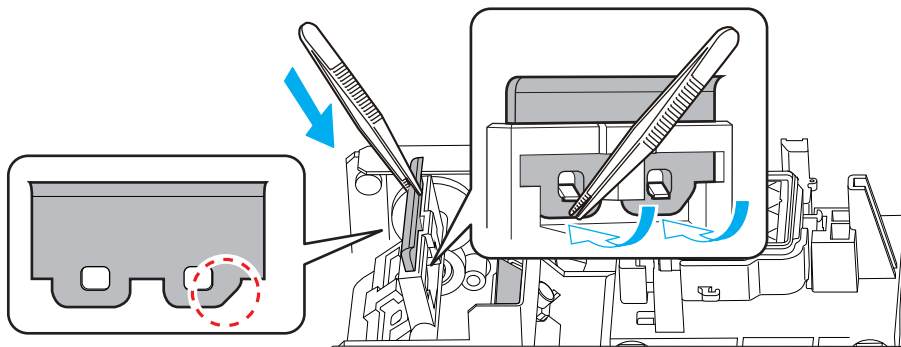

(5) Click [Next].

6. When the operation is complete, close the front cover.

7. Click [Finish].

The print-head carriage returns to the original position, and then head cleaning starts. When head cleaning finishes and two short beeps sound, the work is complete.

## Replacing the Felt Wiper

The felt wiper is a component that is used for cleaning the print heads.

You will be notified with [The time for felt wiper replacement has arrived.] when it is time to replace the felt wiper, so replace it when you are so notified.

For information about purchasing felt wipers, contact your authorized dealer.

### ⚠ WARNING

Be sure to perform operations as specified by the instructions, and never touch any area not specified in the instructions.

Sudden movement of the machine may cause injury.

### IMPORTANT

When the warning alarm sounds during felt wiper replacement

To prevent the print heads from drying out, an alarm sounds about 30 minutes after the start of the operation. Perform the operation by following the message displayed in Utility.

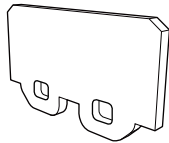
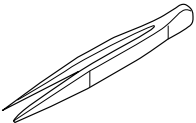

Required items	
	
Felt wiper	Tweezers

### MEMO

Use the following link to view a reference video for this procedure. We recommend that you view this video to understand the overall flow of work.

<https://youtu.be/dQCQqWV16kA>

## Procedure

1. Remove the object to be printed on.
2. Click  on the Utility home screen to display the message.
3. Click  under [The time for felt wiper replacement has arrived.].  
The [Felt Wiper Replacement] window appears.
4. Put on protective equipment (gloves and glasses), and then click [OK].  
The print-head carriage moves to a location where felt wiper replacement is possible.
5. Follow the on-screen instructions and perform the procedure below to replace the felt wiper.
  - (1) Open the front cover.
  - (2) Disconnect the hooks (①), and then pull the felt wiper up and out (②).

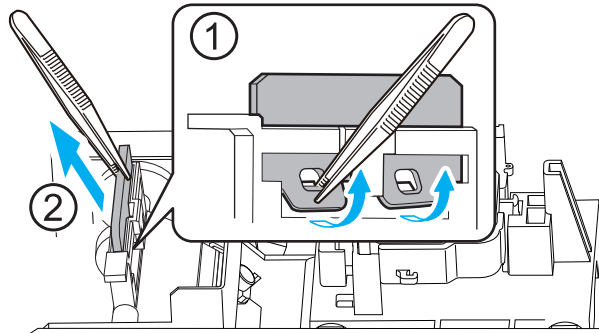

- (3) Insert a new felt wiper.
- (4) Attach the felt wiper to the hooks.

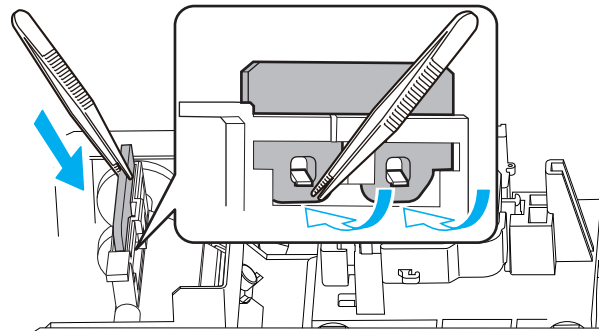

- (5) Click [Next].

**6.** When the operation is complete, close the front cover.

**7.** Click [Finish].

The print-head carriage returns to the original position, and then head cleaning starts. When head cleaning finishes and two short beeps sound, the work is complete.

## Replacing the Cap Top

The cap top is a protective part that prevents the print heads from drying out.

You will be notified with [The time for cap top replacement has arrived.] when it is time to replace the cap top, so replace it when you are so notified.

For information about purchasing cap tops, contact your authorized dealer.

### ⚠ WARNING

**Be sure to perform operations as specified by the instructions, and never touch any area not specified in the instructions.**

Sudden movement of the machine may cause injury.

### IMPORTANT

**When the warning alarm sounds during cap top replacement**

This operation consists of three procedures: replacement, cleaning, and confirmation. To prevent the print heads from drying out, a warning beep sounds about 30 minutes after the start of replacement and about 5 minutes after the start of post-cleaning confirmation. If this beep sounds, perform operations by following the message displayed in the Utility window.

### MEMO

Cap top replacement involves the process of removing the ink tube. If the removed tube is exposed to ultraviolet light, the ink may cure inside the tube.

If the area around the cap top is dark, use a light that does not emit UV light (light with a wavelength of 450 nm or shorter).

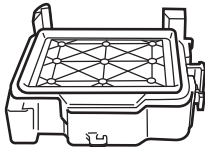
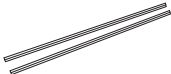
Required item	
	
Cap top	Twist ties (2) <sup>*1</sup>



\*1 Use two of the three twist ties included with the replacement cap top. The remaining twist tie is a spare.

### MEMO

Use the following link to view a reference video for this procedure. We recommend that you view this video to understand the overall flow of work.

<https://youtu.be/ufzWC3gW55o>

## Procedure

1. Remove the object to be printed on.
2. Click  on the Utility home screen to display the message.
3. Click  under [The time for cap top replacement has arrived.].

The [Cap Top Replacement] window appears.

4. Put on protective equipment (gloves and glasses), and then click [Next].

The print-head carriage moves to a location where cap top replacement is possible.

5. Follow the on-screen instructions and perform the procedure below to replace the cap top.

- (1) Open the front cover.

Open the front cover, and then click [Next].

- (2) Push the foundation to which the cap top is attached to the right.

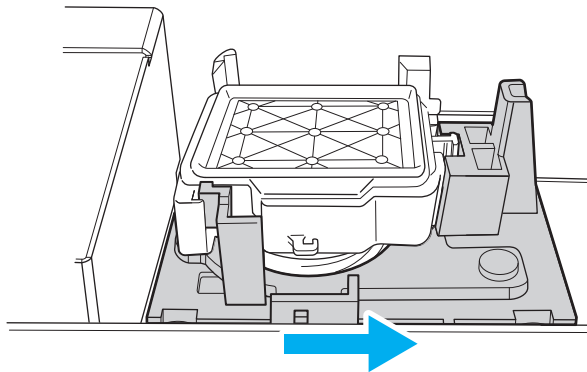

While still pushing the foundation, click [Next].

- (3) Remove the cap top.

- The cap top is fixed in place at the three points shown in the figure. Push the cap top down, and then slide it to the left to dislodge it.
- Once the cap top is removed, release the foundation that was holding it.

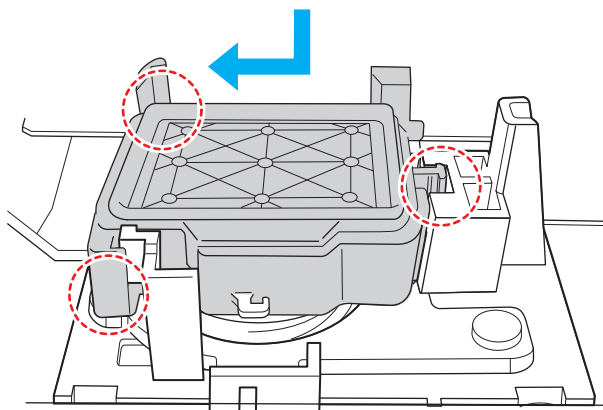

After removing the cap top, click [Next].

- (4) Remove the spring inserted in the groove on the bottom of the cap top.

If you cannot remove the spring correctly, twist it slightly. This will make it easier to remove the spring.

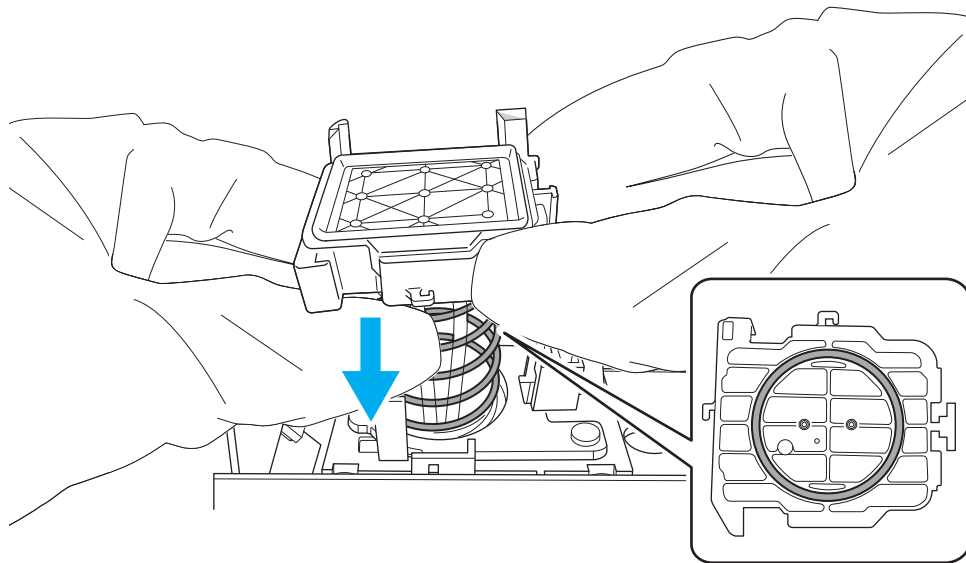

After removing the spring from the groove, click **[Next]**.

- (5) Hold the upper part of the tubes, and then remove the cap top from the tubes.

**IMPORTANT**

Take care to ensure that the tubes do not fall into the machine.  
If the tubes fall into the machine and you cannot remove them, contact your authorized dealer.

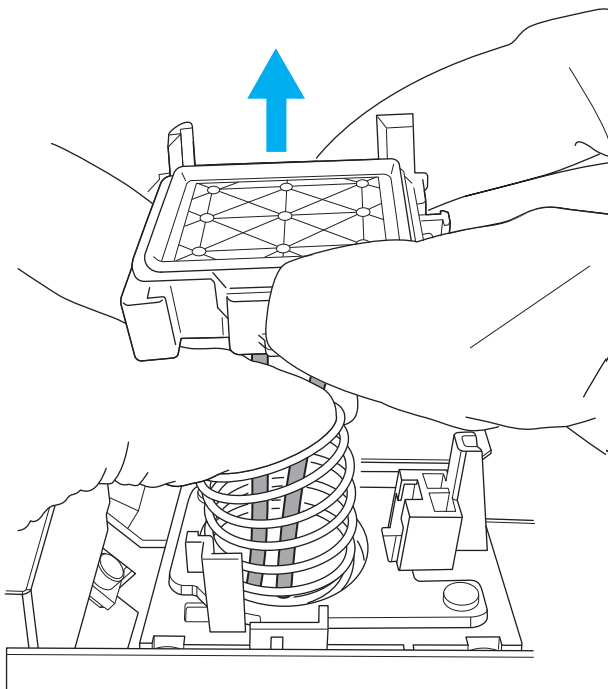

After removing the cap top from the tubes, click **[Next]**.

- (6) Compress the spring.
- i. Remove the spring from the foundation.
  - ii. Compress the spring with twist ties.

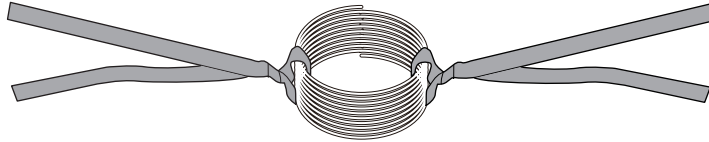

- iii. Attach the spring to the foundation.
- (7) Attach the new cap top to the tubes.
  - i. Hold the cap top with the two protrusions on the cap top facing toward the back.
  - ii. Insert the sleeve (A) at the end of the tubes into the cap top by pinching the end of the sleeve so as not to push the sleeve deep into the tube.

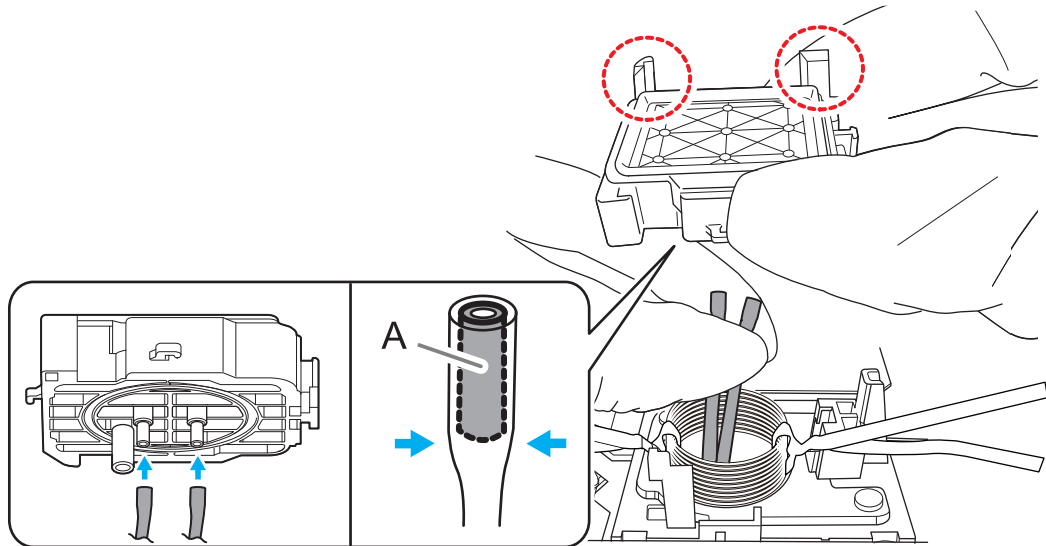

After inserting the tubes, click **[Next]**.

- (8) Remove the twist ties that are compressing the spring.

**IMPORTANT**

Release the spring slowly, ensuring that the force of the spring is not suddenly applied to the cap top.

- (9) While holding the cap top, insert the spring into the bottom of the cap top (A) and the groove on the foundation (B).

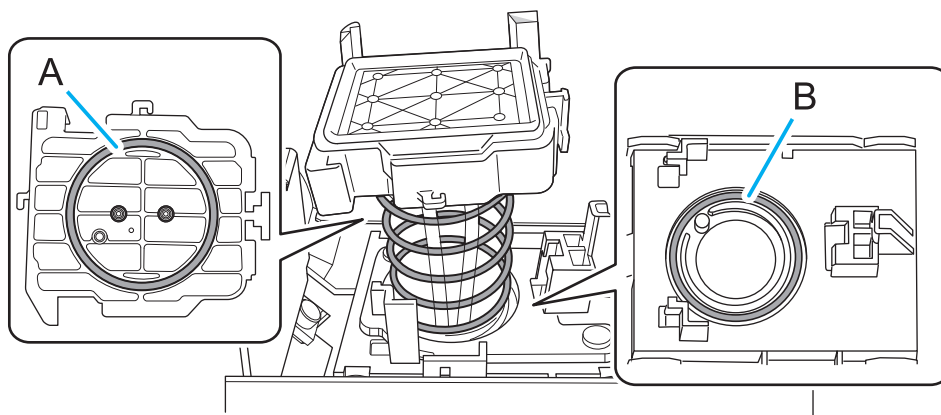

After inserting the spring, click **[Next]**.

- (10) Push the foundation to the right.



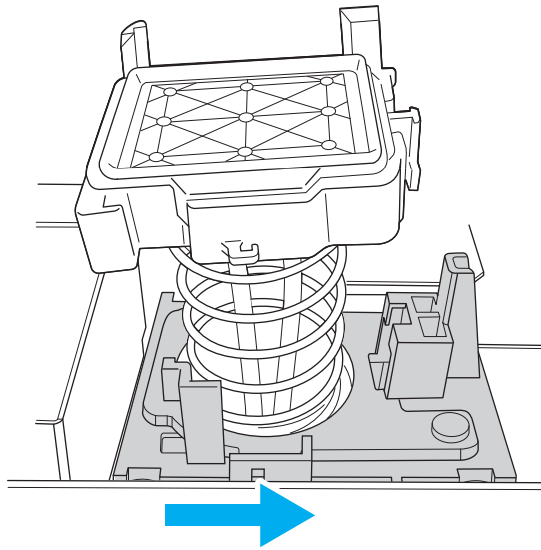

While still pushing the foundation, click [Next].

(11) Attach the cap top to the foundation.

Push the cap top down (①) with the cap top in a horizontal position and slide it to the right (②).

**MEMO**

**Correct Attachment**

- The cap top is secured in the three positions shown in the figure.
- The cap top and foundation are parallel.

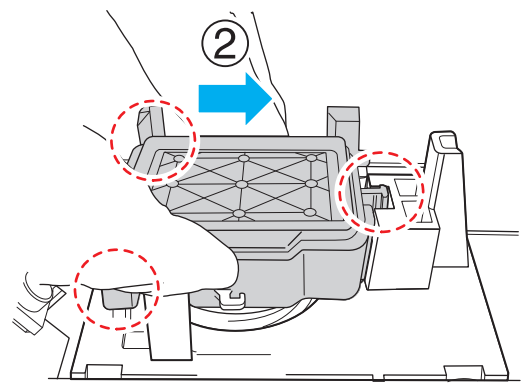
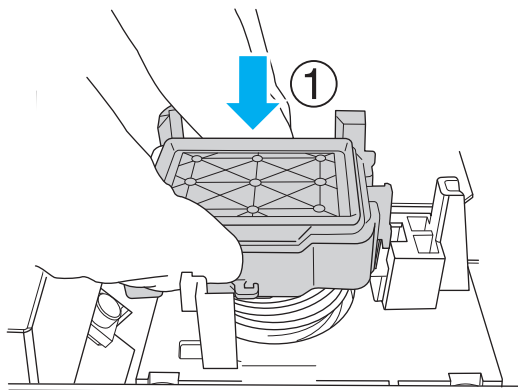

After attaching the cap top, click [Next].

(12) When the operation is complete, close the front cover.

6. Click [Next].

The print-head carriage returns to the original position, and then head cleaning starts. When head cleaning finishes and two short beeps sound, proceed to the next step.

7. Open the front cover, and then check that there is ink on the cap top.

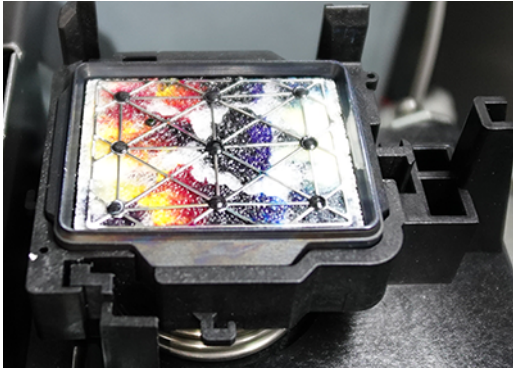

If there is no ink on the cap top, the tubes may not have been inserted as described in step 5-(7). Remove the cap top again and check the connection.

**8. Close the front cover, and then click [Finish].**

The print-head carriage returns to the original position, and then head cleaning starts. When head cleaning finishes and two short beeps sound, the work is complete.

## Replacing the Deodorizer Filter

We recommend replacing the deodorizer filter every year. However, the deodorizing performance decreases with frequency of use. If you start to smell odors coming from near the machine, replace the filter even if it has been in use for less than a year.

### MEMO

#### Handling the Filter

- If the filter is dropped or struck, it will break. Handle it with care.
- Touching or tilting the front and rear surfaces of the filter may cause the activated charcoal to stick to your hands or fall to the floor. Handle it in such a way that it does not contaminate its surroundings. Also, use gloves if necessary.

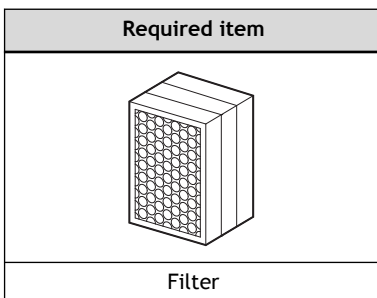

### MEMO

Use the following link to view a reference video for this procedure. We recommend that you view this video to understand the overall flow of work.

<https://youtu.be/LXL6ymGf8u0>

## Procedure

1. Turn off the sub power, and then turn off the main power.
2. Open the front cover.
3. If manual cleaning tools are stored in front of the deodorizer, move them.
4. Lift up ① the filter holder (A) at the top of the filter and pull the filter toward you ② to remove it. Lift the filter up by holding the rubber at the end of the filter holder.

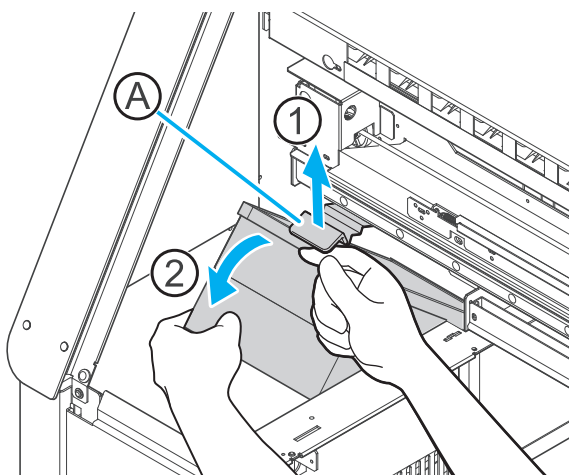

5. Install the new filter with the side with the circles pattern facing you.

**IMPORTANT**

Install the filter in the orientation shown in the following figure. Installing it backward will shorten the service life of the filter.

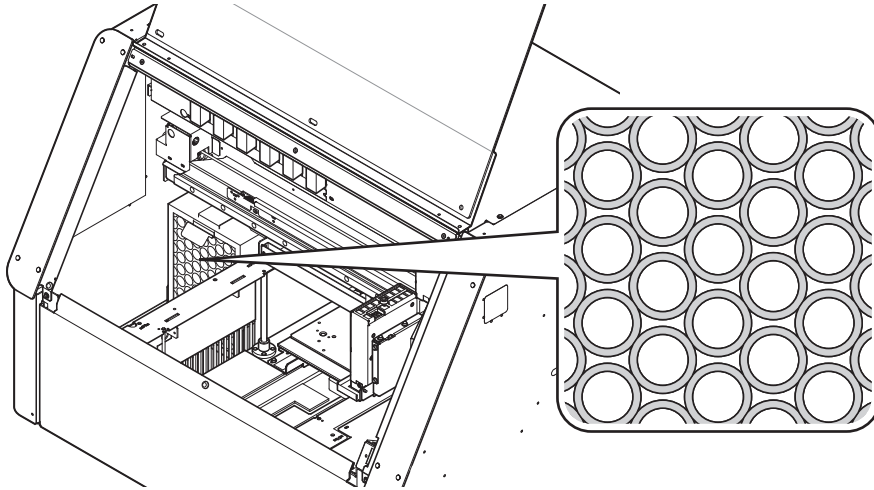

# Troubleshooting

# Troubleshooting Methods

---

Print Quality Problems .....	206
Print Results Are Coarse.....	206
Print Results Contain Horizontal Bands .....	207
Colors Are Unstable or Uneven.....	208
The Object Becomes Soiled.....	209
Excessive Misting / Nozzle Drops Out / Ink Smearing or Dripping .....	210
Ink Adhesion Is Poor.....	211
Printing Position Using Alignment Markers Is Misaligned .....	212
Alignment Markers Cannot Be Read .....	214
Machine Problems .....	216
The Printer Unit Does Not Run (Does Not Print) .....	216
Why Has the Print-Head Carriage Stopped Moving? .....	218
The Flat Table Does Not Move.....	220
Network Trouble .....	221
Printer Is Not Displayed on the Roland DG Connect Hub .....	221
Roland DG Connect Hub Does Not Change from "Loading" .....	221

# Print Quality Problems

## Print Results Are Coarse

### Is there any dot drop-out or dot displacement?

Carry out a nozzle drop-out test and make sure no dot drop-out or dot displacement occurs. If dot drop-out or dot displacement is present, perform head cleaning.

[P. 160 Action Taken When Dot Drop-out or Dot Displacement Occur](#)

### Are the appropriate settings selected at the time of printing?

Printing quality may seem coarse depending on the [Media Type] and [Print Quality] selected when printing. Check the settings at the time of printing.

### Is the printer's installation site appropriate?

Never install the machine in a location where it is tilted or where it may wobble or experience vibration. Also, never install the machine in a location that is exposed to direct sunlight.

Doing so may result in dot drop-out, dot displacement, or other problems with reduced print quality, or may even result in malfunction.

### Is the object loaded correctly?

If the object is not loaded correctly, printing may be adversely affected. Check the following.

- Is the object securely fixed in place?
- Is the height setting of the object correct?

#### RELATED LINKS

- [P. 160 Action Taken When Dot Drop-out or Dot Displacement Occur](#)

---

## Print Results Contain Horizontal Bands

### Is there any dot drop-out or dot displacement?

Carry out a nozzle drop-out test and make sure no dot drop-out or dot displacement occurs. If dot drop-out or dot displacement is present, perform head cleaning.

[P. 160 Action Taken When Dot Drop-out or Dot Displacement Occur](#)

### Has printing been paused partway through?

Resuming printing after pausing while printing was partway through may produce horizontal stripes in the printing area. Avoid pausing printing.



## Colors Are Unstable or Uneven

### Did you shake the ink cartridges before installing them?

Shake new ink cartridges 50 times (about 20 seconds) with a stroke length of around 5 cm (1.97 in.) horizontally in each direction when shaking before you install them.

For white ink, before starting the day's work, remove the ink cartridge and shake it 50 times (about 20 seconds) with a stroke length of around 5 cm (1.97 in.) horizontally in each direction before inserting it again.

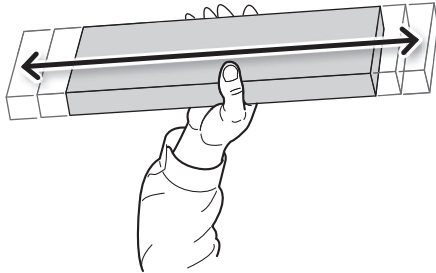

### Are colors still uneven after mixing the ink by shaking the ink cartridges?

If uneven color issues with white ink still occur even after shaking the ink cartridges to mix the ink, perform step 2 of [Action Taken When Uneven Color Issues Occur \(White Ink\)](#) and subsequent steps.

### Are the operating parameters set to appropriate values?

Depending on the [Printing Movement Range], the color may be unstable. If you have changed the setting, try setting to [Full Width].

[P. 120 Minimizing Print-head Carriage Movement](#)

### Was printing paused partway through?

When printing is paused, the coloring at the seam may be altered when printing resumes. Avoid pausing printing.

Printing may also pause when data is not sent from the computer quickly enough. We recommend not performing any other tasks with the computer while printing is in progress.

### Is the printer installed in a level and stable location?

Never install the machine in a location where it is tilted or where it may wobble or experience vibration. Doing so may result in reduced print quality.

### Are the irradiation surfaces of the UV-LED device dirty?

If the irradiation surfaces are dirty, this can reduce ink adhesion and the quality of the printed materials. Check the level of dirt and clean at the appropriate times.

[P. 175 UV Lamp Manual Cleaning Method](#)

### Are you printing in a location subject to severe changes in the operating environment?

Large fluctuations in temperature or humidity while printing is in progress may cause the colors to change partway through the printing. When printing, use the machine in a location where the temperature and humidity are stable.

---

## The Object Becomes Soiled

### Are the print heads dirty?

The following may cause ink to drip on the object to be printed on during printing.

- Buildup of fibrous dust (lint) around the print heads.
- The print heads are in contact with the object and ink is adhering to the print heads.

If this happens, perform manual cleaning.

### Is the humidity of the room too low?

Use in an environment of 35 to 80% RH (but no condensation).

#### RELATED LINKS

- [P. 167 Manual Cleaning](#)

---

## Excessive Misting / Nozzle Drops Out / Ink Smearing or Dripping

### Is the object charged with static electricity?

If the object is charged with static electricity, the print heads will not be able to discharge ink correctly. As a result, issues such as mist generation, nozzle drop-out, contamination of the object, ink smearing, and ink dripping may occur.

Perform the following operations to eliminate static electricity and prevent the generation of static electricity.

- **Remove static electricity from workers.**

Workers should wear clothing and shoes that are resistant to generation of static electricity, and touch a wall or other surface before touching the object to discharge any static electricity from the workers.

- **Remove any static electricity from the object.**

It is easy for the object to be charged with static electricity when the protective sheet or film is removed from the object. Use a static removal brush or anti-static cloth to discharge any static electricity from the object.

- **Humidify the area around the printer to prevent static electricity generation.**

Low temperatures and humidity are conducive to the generation of static electricity. Use the machine in an environment of 35-80% RH (no condensation), for example, by humidifying the room with a humidifier.

---

## Ink Adhesion Is Poor

### Did you use a primer?

Ink adhesion may be improved by using a primer. After creating print data in FlexiDESIGNER, select "with primer" in [Print parameters].

### Is the print surface soiled?

Ink adhesion will be poor if the print surface is dirty. After loading the object, degrease the print surface using anhydrous ethanol or isopropyl alcohol.

### Are the irradiation surfaces of the UV-LED device dirty?

If the irradiation surfaces are soiled with ink mist or other contaminants, UV illumination may be reduced, resulting in poor ink adhesion. Perform [Cleaning the UV-LED devices](#).

### Is the ambient temperature too low?

Low ambient temperatures in and around the machine, such as low room temperatures or where directly exposed to air-conditioner breezes, may cause poor ink adhesion. During printing, the ambient temperature should be set to 20 to 32 °C (68 to 89.6 °F; 22 °C [71.6 °F] or higher is recommended).

## Printing Position Using Alignment Markers Is Misaligned

### Is the object too thick?

When placing a thick object and then performing imaging of the alignment marker, the thicker the object is, the more it is enlarged in imaging relative to the size of the flat table, even in the same printing area. This is the same principle involved when a person in the distance appears smaller and a person nearby appears larger when performing imaging.

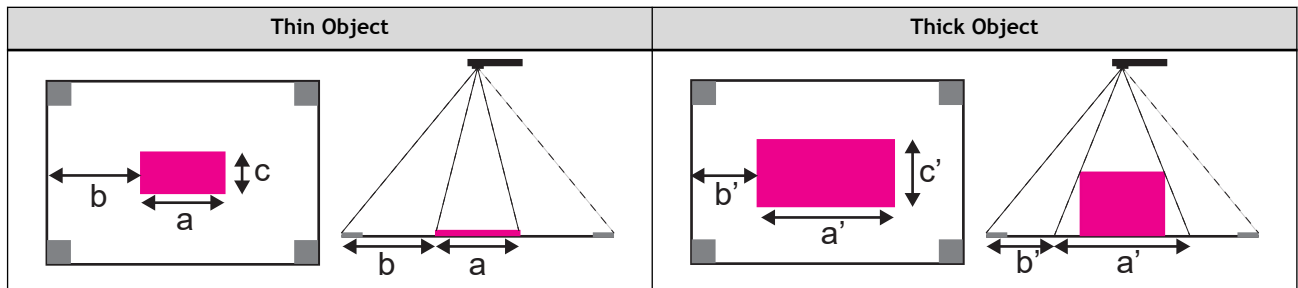

Since the alignment markers are printed inside the white line (210 mm × 148 mm [8.26 in. × 5.82 in.]) of the maximum printing area, when the object is imported into FlexiDESIGNER, it is recognized as a larger size ( $a'$  and  $c'$ ) than the actual size ( $a$  and  $c$ ) and the margins are reduced accordingly ( $b \rightarrow b'$ ).

Then, when creating print data in FlexiDESIGNER, the data will be created based on a size larger than the actual printing size of the object. Since the data created in the enlarged printing area will be printed in the actual size, misalignment of and extending beyond the printing position will occur.

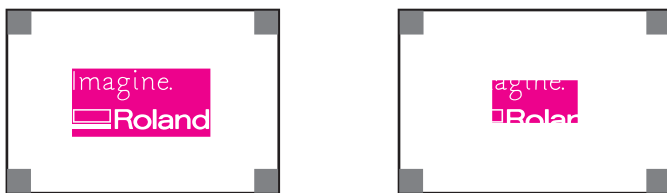

Therefore, when printing on a thick object, it is necessary to create print data with the assumption that the object will be enlarged. Refer to the following to create print data that is small relative to the FlexiDESIGNER screen.

- Object with thickness 10 mm (0.39 in.) and width 150 mm (5.90 in.): Max. approx. 6 mm (0.23 in.)
- Object with thickness 30 mm (1.18 in.) and width 150 mm (5.90 in.): Max. approx. 17 mm (0.66 in.)

### Is there a misalignment between the imaging position and the printing position?

The longer the distance from the center position of the camera ( $a$ ) to the left/right/front/back, the greater the misalignment (the misalignment between  $c$  and  $c'$  is greater than the misalignment between  $b$  and  $b'$ ).



When imaging alignment markers and the object to be printed, perform imaging from directly above the position ( $d$ ) from which you do not want there to be any displacement. Then, measure the object, determine the printing size ( $e$ ), and create print data.

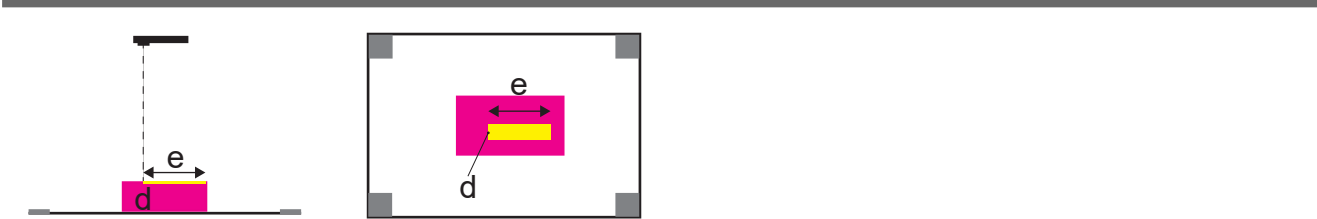

Note that the higher the position at which imaging is performed, the smaller the misalignment, but it may become more difficult to read the alignment markers. The optimal imaging height varies from camera to camera, so perform imaging several times to find a good balance between the amount of misalignment and the reading.

## Alignment Markers Cannot Be Read

### The alignment markers are out of focus in the image.

If the alignment markers are not in focus in the image, they may not be readable. Perform imaging by focusing on the alignment markers.

### The place where the imaging is performed is too bright/dark.

If you perform imaging in an excessively bright place, the black portion of the alignment marker cannot be recognized (A), and if you perform imaging in an excessively dark place, the white portion cannot be recognized (B).

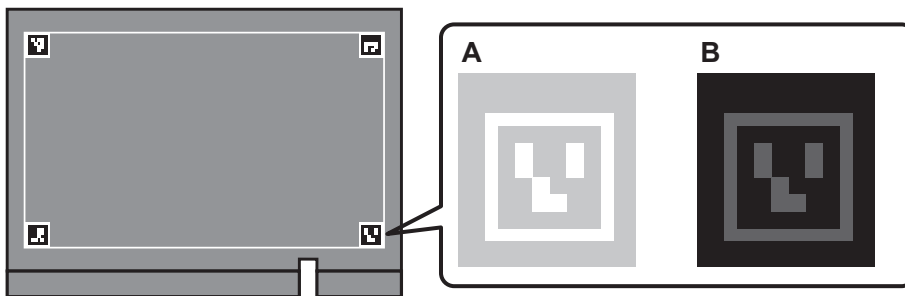

If you perform imaging in a place that is excessively bright or dark, the alignment markers cannot be read and image conversion will fail.

Perform imaging by adjusting the light shining on the alignment markers.

- Adjust by lowering or raising the flat table
- Adjust room brightness
- Adjust light source position or printer position
- Adjust camera exposure

### The brightness difference between the four alignment markers is significant.

If you do not perform imaging of the four alignment markers with the same level of brightness for each marker, some locations may not be recognizable. If all four markers are not recognized, image conversion will fail.



Perform imaging by making sure that the brightness is the same for the four alignment markers.

- Adjust by lowering or raising the flat table
- Adjust light source position or printer position
- Adjust by increasing or decreasing the light coming from the light source

### The color difference between the alignment markers and the tape is minor.

If the [Print White Alignment Marker Background] check box is cleared, the image conversion will fail if the tape color cannot be recognized as white.

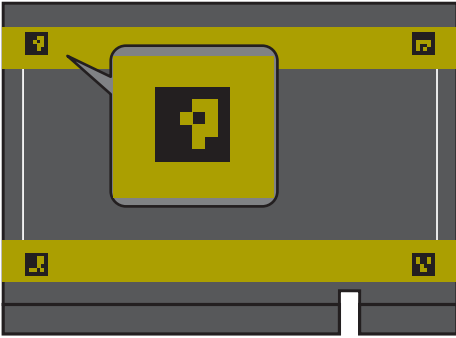

Select the [Print White Alignment Marker Background] check box, and then print the alignment markers again.

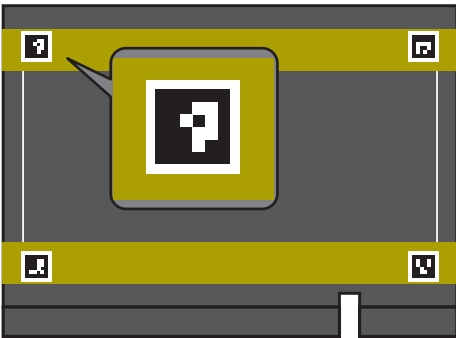



# Machine Problems

## The Printer Unit Does Not Run (Does Not Print)

There is a problem with print data, and the printer does not work.

If the print data is larger than the printing area, it cannot be printed. Check the print data and the printing area, and change the one that is too large.

There is a problem in Utility, network, machine, or other technical issue and the printer does not work.

### Procedure

1. Check for Notifications/Errors/Fatal Errors in Utility, and then take necessary action.
2. Make sure that the print data has been sent normally.  
Make sure the machine to be used is selected in the [Send to Device] dialog box.
3. If you have more than one BD-8, make sure the machine you are using is correctly selected in the Roland DG Connect Hub.
4. Check that the status LED for the LAN cable connector is lit in green.

If the status LED (A) for the LAN cable connector is not lit in green, the network connection has not been made correctly. Check whether or not the network routing is appropriate. Try connecting the computer and the machine to the same hub or connecting them directly using a crossover cable. If this makes it possible to perform output, it means the problem is in the network itself.

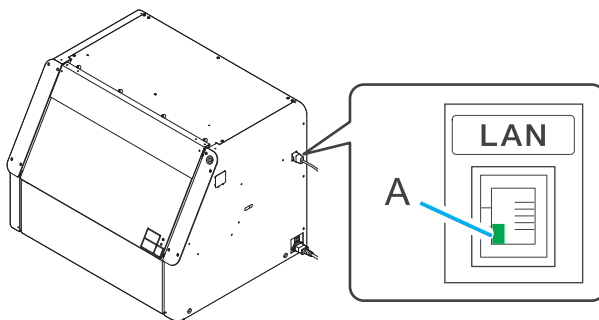

#### MEMO

The activity LED on the top of the status LED flashes orange while data is being received from the network.

5. Make sure that the LAN network settings are correct.  
If printing is not possible even though the status LED (green) for the Ethernet connector is lit, make sure the IP address and other settings are appropriate. The settings on both the machine and the computer must be appropriate.  
Redo the settings, checking to ensure that the IP address does not conflict with the IP address for another device on the network, that the port setting for the software RIP specifies the IP address set on the machine, that the settings have no typing errors, and for other such problems.
6. Check that the sub power is turned on.  
Check that the sub power button is not lit in red.  
[P. 15 Machine State Indicated by the Sub Power Button's Lamp](#)

7. Check that the front cover and maintenance cover are closed.
8. Turn the sub power off and back on again, and then perform the printing operation again.  
If it is still not possible to print, contact your authorized dealer.

## Why Has the Print-Head Carriage Stopped Moving?

The print-head carriage stopped above the flat table.

Follow the procedure below to return the print-head carriage to the standby position so that the print heads do not dry out.

If the same issue occurs again, contact your authorized dealer.

### Procedure

1. Check for Notifications/Errors/Fatal Errors in Utility, and then take necessary action.
2. Turn the sub power off, and then back on again.
  - If the print-head carriage moves to the home position (the right side), recovery has ended successfully.
  - If the print-head carriage still does not move, proceed to the next step.
3. Try switching off the sub power, followed by the main power, then switching on the main power again, followed by the sub power.
  - If the print-head carriage moves to the home position (the right side), recovery has ended successfully.
  - If the print-head carriage still does not move, proceed to the next step.
4. Check the position of the wiper and felt wiper.
  - If the wiper or felt wiper touches the print heads, leave the machine as-is and contact your authorized dealer.
  - If the wiper (A) and felt wiper (B) are in a position where they do not contact the print heads\*<sup>1</sup> as shown in the following figure, proceed to the next step.

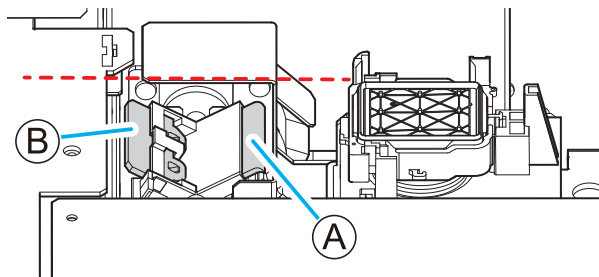

5. Follow the procedure below to move the print-head carriage.
 

This operation is an emergency measure to prevent the print heads from drying out. After performing this operation, contact your authorized dealer.

  - (1) Switch off the sub power and main power, and then open the front cover.
  - (2) Touch the location shown in the figure (next to the ink slots) to discharge any static electricity.

\*1 If the position is lower than the dashed line, the print heads and the wiper or felt wiper will not come in contact.

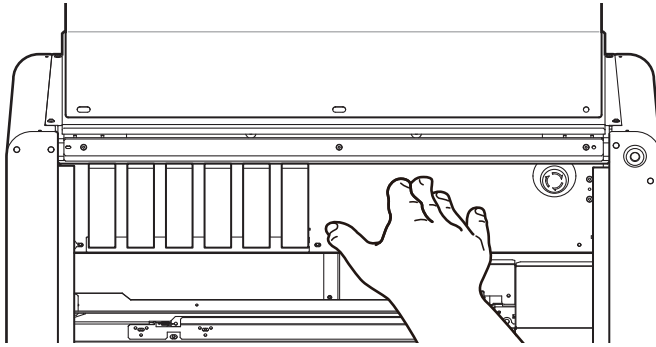

- (3) Gently move the print-head carriage to the right by hand.

The print-head carriage stops once it reaches position ①. The print-head carriage is fixed in position ② after moving about 15 mm (0.59 in.) further from this position.

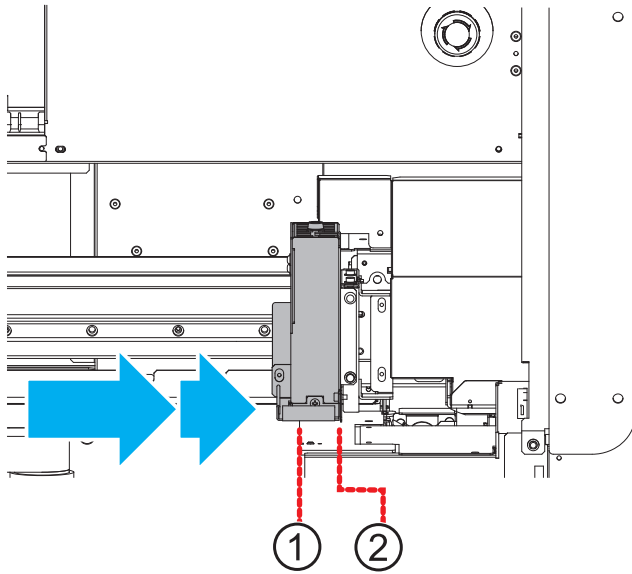

## The Flat Table Does Not Move

The flat table stopped working when setting the height and printing area.

### Procedure

1. Check for Notifications/Errors/Fatal Errors in Utility, and then take necessary action.
2. Check that the front cover and maintenance cover are closed.
3. Check the lower part of the flat table and the front and rear movable components to make sure that no foreign objects are caught in them.  
Remove any foreign objects you find.
4. Turn off the sub power, turn it on again, and then configure the settings again.

# Network Trouble

## Printer Is Not Displayed on the Roland DG Connect Hub

The PC on which the Roland DG Connect Hub is installed and the printer are not in the same subnet. The PC in question and the printer must be located in the same subnet. For details, contact your network administrator.

The PC on which the Roland DG Connect Hub is installed and the printer cannot be used in the same subnet.

Connect the PC in question directly to the printer. For information on connection and setup, see "Installation and Initial Settings."

### RELATED LINKS

- [BD-8 Installation and Initial Settings](#)

## Roland DG Connect Hub Does Not Change from "Loading"

Does your Windows firewall allow communication?

Check your firewall settings.

### RELATED LINKS

- [Support Site](#)

# Frequently Asked Questions

---

Quality Improvement Section.....	223
Printing on a Thick, Transparent Object.....	223
Printing Without Being Affected by the Color of the Object (White Printing on a Base).....	224
Printing on an Uneven Surface .....	225
Useful Functions Section .....	226
Printing Using Commercially-available Application Software .....	226

# Quality Improvement Section

## Printing on a Thick, Transparent Object

Transparent objects with a thickness of 20 mm (0.79 in.) or more require more frequent cleaning. To avoid cleaning during printing, create print data as follows.

- Create print data that is long in the vertical direction, and then print with the printing area arranged vertically.

You can increase the time until cleaning if the width is 100 mm (3.94 in.) or less.

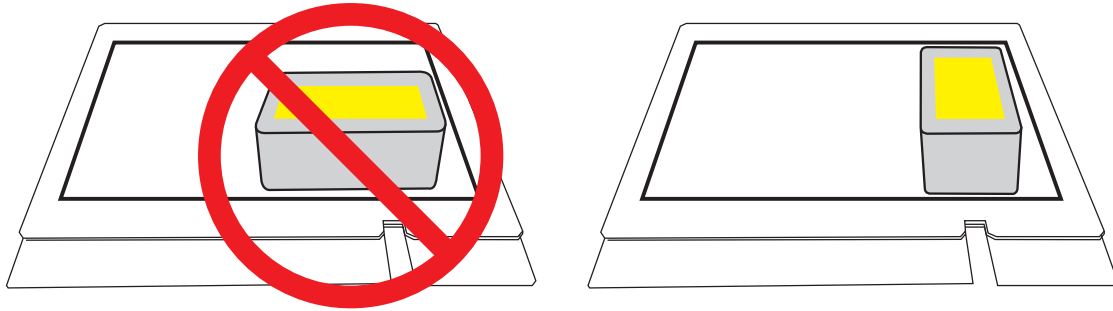

- When printing white above or below CMYK, print the white plate and the CMYK plate separately.

Introduction to FlexiDESIGNER: <https://downloadcenter.rolanddg.com/BD-8>



## Printing Without Being Affected by the Color of the Object (White Printing on a Base)

When printing directly on a dark-colored object, it becomes difficult to hide the base and the CMYK colors will develop poorly. In addition, transparent objects allow light to penetrate through them, which also results in poor CMYK color development. To improve CMYK color development, print in white on the base.

### MEMO

White plates cannot be generated for photo data sizes such as jpeg. If you mask with shapes in FlexiDESIGNER, you can generate a white plate that conforms to the shapes.

### Procedure

1. Create CMYK print data in FlexiDESIGNER.  
The print data created here does not require the creation of a white plate for the base.
2. Click .  
The [Send to Device] window appears.
3. Click [Print parameters].
4. Set the following with [Quality Settings] on the [Quality] tab.
  - [Media Type]: User's choice
  - [Print Quality]: User's choice
  - [Mode]: [White->CMYK]
5. Select the [White Plate Generation] check box in [Special Color Plate Generation].
6. In [Generated Pattern], select the following.
  - [Print Area]: A white plate is generated under the CMYK plate.
  - [Outside Print Area]: A white plate is generated outside the CMYK plate.
  - [Entire Image]: A white plate is generated for the entire printing area.
7. If adjusting the size of the white plate, select [Yes] under [Size Correction].  
If [Size Correction] is applied, the white plate will become slightly smaller.
8. To close the window, click [OK].
9. In the [Send to Device] window, click [Send].  
The print data is sent to the printer, and then printing starts.

### RELATED LINKS

- [Introduction to FlexiDESIGNER](#)
- [P. 87 Print Parameters \(FlexiDESIGNER\)](#)

---

## Printing on an Uneven Surface

Print in distance mode if, for example, the print surface is uneven by 2 mm (0.08 in.) or more.

After creating print data with FlexiDESIGNER, click [Print parameters] and select [Generic Distance] or [Generic Distance with Primer] from [Quality Settings]>[Media Type] on the [Quality] tab.

# Useful Functions Section

## Printing Using Commercially-available Application Software

This is the printing procedure for printing by utilizing existing data (.ai, .pdf, etc.) or by using commercially-available application software (Adobe Illustrator, CorelDRAW, etc.).

### Procedure

1. Create print data using commercially-available application software.  
Save the file in a file format that can be imported into VersaWorks (PDF, EPS, and similar formats).
2. Set up the object.
3. Follow the procedure below to start VersaWorks.
  - (1) Start Roland DG Connect Hub.
    - Windows 11
      - i. Click [Start]>[All apps].
      - ii. From the list of apps (programs), click [Roland DG Corporation]>[Roland DG Connect Hub].
    - Windows 10
      - i. Click [Start].
      - ii. From the list of apps (programs), click [Roland DG Corporation]>[Roland DG Connect Hub].
  - (2) Click the machine (BD-8) to use.
  - (3) Click [Open] for VersaWorks.
4. Use VersaWorks to print with various settings configured.
  - If the machine is not registered, refer to the Installation Guide and register the machine.
  - For information on how to use VersaWorks, see the VersaWorks Help.

### RELATED LINKS

- [BD-8 Installation Guide](#)
- [VersaWorks Help](#)

# Utility Notification/Errors/ Fatal Errors

---

Notifications.....	228
[When output, cleaning, and other operations are completed, discard the discharged fluid.] .....	228
[The drain cartridge was removed.].....	228
[The time for manual cleaning has arrived.] .....	228
[Perform manual cleaning.] .....	229
[The time for wiper replacement has arrived.].....	229
[The time for felt wiper replacement has arrived.] .....	229
[The time for cap top replacement has arrived.].....	229
[Print head protection mode has activated.].....	229
[The time for ink mixing has arrived.] .....	229
[The connection to the unit was lost.].....	230
[There is ink that has expired.] .....	230
[The time for manual cleaning of the UV lamp has arrived.] .....	230
ERROR .....	231
[Ink Cartridge Error] .....	231
[Cover Open Error].....	231
[Manual Cleaning Tool Error].....	231
[Rotary Mode Mismatch Error].....	232
[Flat Table Height Error].....	232
[Print Data Larger Than Printing Area] .....	232
[Insufficient Printing Area].....	232
[Manual cleManual Cleaning Required for Printinganing required] .....	232
[Replace the drain pack.].....	232
Fatal Error .....	234
[Service Call: ] .....	234
[Motor Error: ] .....	234
[Print Head Dry-out Error] .....	234
[Low Temperature Error: ] .....	234
[High Temperature Error: ].....	234
[Pump Stop Error] .....	235
[Emergency Stop Error] .....	235

# Notifications

You can check notifications by clicking  on the Utility home screen. When there are notifications, their number is displayed on the icon.

## [When output, cleaning, and other operations are completed, discard the discharged fluid.]

This message appears when a certain amount of discharged fluid collects in the drain pack.

Remove the drain cartridge, and then dispose of the discharged fluid as directed in the Utility window.

At the time this message is displayed, the drain pack has not reached the limit of its use. It can continue to be used if, for example, a replacement drain pack is not readily available.

However when the drain pack has reached its service limit, [Replace the drain pack.] is displayed. If this error appears, the drain pack can no longer be used, so if [When output, cleaning, and other operations are completed, discard the discharged fluid.] appears, dispose of the discharged fluid as soon as possible.

### RELATED LINKS

- [P. 188 Replacing the Drain Pack](#)

## [The drain cartridge was removed.]

This message appears when the drain cartridge is removed.

When disposing of discharged fluid is finished, install the drain cartridge as soon as possible.

This message appears when the protrusion on the drain cartridge is damaged.

If the protrusion circled below is damaged by dropping or other causes, the drain cartridge cannot be recognized as having been installed.

Replace the drain cartridge with a new one.

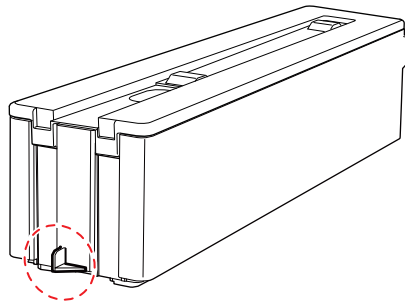

## [The time for manual cleaning has arrived.]

This message appears when it is time to perform manual cleaning.

Click  for [The time for manual cleaning has arrived.] and perform manual cleaning.

### RELATED LINKS

- [P. 167 Manual Cleaning](#)

## [Perform manual cleaning.]

This message appears if you continue to use the machine without performing manual cleaning even after [The time for manual cleaning has arrived.] appeared.

You will not be able to set up the object if this notification is displayed.

Click  for [Perform manual cleaning.] and perform manual cleaning.

If you attempt to perform setup, the [Manual cleManual Cleaning Required for Printinganing required] message appears. Click [OK] to switch to the manual cleaning screen.

## [The time for wiper replacement has arrived.]

This message appears when it is time to replace the wiper.

Click  next to [The time for wiper replacement has arrived.] to replace the wiper.

### RELATED LINKS

- [P. 192 Replacing the Wiper](#)

## [The time for felt wiper replacement has arrived.]

This message appears when it is time to replace the felt wiper.

Click  next to [The time for felt wiper replacement has arrived.] to replace the felt wiper.

### RELATED LINKS

- [P. 194 Replacing the Felt Wiper](#)

## [The time for cap top replacement has arrived.]

This message appears when it is time to replace the cap top.

Click  next to [The time for cap top replacement has arrived.] and replace the cap top.

### RELATED LINKS

- [P. 196 Replacing the Cap Top](#)

## [Print head protection mode has activated.]

This message appears when the ink in use may not be a product specified by Roland DG Corporation.

To obtain optimal performance, we recommend that you use ink specified by Roland DG Corporation. To purchase ink, contact your authorized dealer.

## [The time for ink mixing has arrived.]

This message appears when the white ink needs to be mixed.

### Procedure

1. Click  under [The time for ink mixing has arrived.].
2. Pull out the white ink cartridge, and shake the ink cartridge 50 times (about 20 seconds) horizontally with a stroke length of around 5 cm (1.97 in.) from each end of the ink cartridge before reinserting it.
3. When the [Was the white ink mixed?] window appears, click [Yes].

### [The connection to the unit was lost.]

This message appears when one of the following situations is detected.

- The main power of this machine switches off.
- The IP address of this machine is changed.
- The LAN cable connecting this machine and the computer is disconnected.

Check the status of this machine, and then perform a recovery action. If the main power is left off, the automatic maintenance function will not be able to operate, which may result in malfunctions. Always keep the main power switched on.

### [There is ink that has expired.]

This message appears when there are ink cartridges that have expired.

### Procedure

1. Click the Notifications window.  
The Ink Information window is displayed.
2. Replace any ink cartridges that have expired.

#### RELATED LINKS

- [P. 185 Replacing Ink Cartridges](#)

### [The time for manual cleaning of the UV lamp has arrived.]

This message appears when it is time to perform manual cleaning.

Click  for [The time for manual cleaning of the UV lamp has arrived.], and perform cleaning of the UV lamp.

#### RELATED LINKS



- [P. 174 Cleaning the UV-LED devices](#)

# ERROR

## [Ink Cartridge Error]

This message appears when one of the following ink cartridge errors is detected.

### MEMO

When an error occurs, the , , , or  icon is displayed next to the corresponding ink type on the screen.

Implement appropriate countermeasures according to the error.

- **When ink runs out**
  - ✖:[Ink has run out.]  
Replace the ink cartridge with a new one.
- **When little ink remains**
  - ⚠:[Remaining ink level low.]  
Printing is not possible if there is no ink. If this message appears, prepare a replacement ink cartridge.
- **When ink has expired**
  - ⚠:[There is ink that has expired.]  
Although you can print with expired ink, it may lead to the following problems and malfunction. We recommend replacing ink when this message appears.
    - Ink leaks from the ink cartridge.
    - The ink viscosity increases, leading to ink discharge issues (which may result in decreased output quality).
    - The ink hardens, leading to printer malfunctions.
- **When an ink cartridge is removed**
  - ➖:[Ink cartridge was removed.]  
Load the removed ink cartridge.
- **When an ink cartridge with the incorrect color is loaded**
  - ❓:[Incorrect ink cartridge was loaded.]  
Remove the incorrectly loaded ink cartridge, and then load the correct ink cartridge.  
When you remove an ink cartridge, ➖: [Ink cartridge was removed.] is displayed.

## [Cover Open Error]

Front cover, maintenance cover or both covers are open.

For safety, the machine may stop if a cover is opened during operation.

Close all the covers.

## [Manual Cleaning Tool Error]

This is displayed when the attached manual cleaning tool is detected at a time other than during manual cleaning. Immediately remove the manual cleaning tool.



### [Rotary Mode Mismatch Error]

This is displayed when the rotary axis unit is attached or removed (the connector is disconnected or connected) without using the Rotary Axis Unit Attachment/Removal menu. It is also displayed for a connector connection failure.

When attaching or removing the rotary axis unit, be sure to do so from [Preferences]>[Rotary Unit Attachment/Removal]. Also be sure to connect the connector securely when attaching.

### [Flat Table Height Error]

This message appears when the head gap sensor comes in the contact with the object.

It is displayed when the object, fixing tape, a retainer, or similar comes in contact with the head gap sensor during non-printing operations.

It is displayed and printing stops when a height error is detected for an object during printing when the clearance setting is [Stop].

It is displayed and printing stops if a height error for the object is detected during printing when the clearance setting is [Readjust] and the problem does not resolve even when the table was lowered to the [Maximum Value (Threshold)].

In all of these cases, make sure that the object is set up correctly or that the size of the object does not exceed the size that can be loaded. Set up the object correctly, or load a printable object of the size that can be loaded.

### [Print Data Larger Than Printing Area]

This message is displayed when there is not enough printing area for the print data.

To continue printing without changing the printing area or the print data, click [Yes]. The portion extending beyond the print area will not be printed.

To cancel printing, click [No]. Make the printing area wider or replace the object with a larger object, and then send the data again.

### [Insufficient Printing Area]

This message is displayed when there is not enough printing area for the test pattern of the nozzle drop-out test or alignment marker printing.

Click [OK] to cancel printing. Then set the printing area again.

### [Manual Cleaning Required for Printing]

This message appears when the user attempts to set up the object while [Perform manual cleaning.] is displayed. Click [OK] to switch to the manual cleaning screen. Perform manual cleaning.

### [Replace the drain pack.]

This message appears when the amount of discharged fluid in the drain pack reaches the specified amount.

Replace the drain pack that is inside the drain cartridge.

## MEMO

When the drain cartridge is detached, the error message changes to [The drain cartridge was removed.].

# Fatal Error

## [Service Call: ]

This is displayed when an unrecoverable error has occurred that requires repair by a service technician. Note the number displayed in Utility, and then switch off the main power. After you switch off the power, inform your authorized dealer of the number that appeared in the Utility window.

## [Motor Error: ]

**A motor error occurred.**

Operation cannot be continued. Turn off the sub power. Next, eliminate the cause of the error, then immediately switch on the sub power.

If the machine is allowed to stand with the error uncorrected, the print heads may dry out and become damaged. This error may be caused by the object or the manual cleaning tool being set up incorrectly.

## [Print Head Dry-out Error]

**This message appears when the print heads are forced to the home position to prevent them from drying out.**

Operation cannot be continued. Switch the sub power off, and then back on.

## [Low Temperature Error: ]

**The internal temperature of the machine has fallen below that at which it can operate.**

This message appears when the temperature falls to 5°C (41°F) or lower during startup or to 2°C (35.6°F) or lower during operation.

Operation cannot be continued. Turn off the sub power.

Bring the installed location to a temperature at which operation is possible (20°C to 32°C [68°F to 89.6°F]), allow the machine to come to room temperature, and then turn on the power.

### RELATED LINKS

- [P. 50 Power Supply Operations](#)

## [High Temperature Error: ]

**The internal temperature of the machine has risen above that at which it can operate.**

This message appears when the temperature rises to 42°C (107.6°F) or higher during startup or operation (when recovering from sleep mode).

Operation cannot be continued. Turn off the sub power.

Bring the installed location to a temperature at which operation is possible (20°C to 32°C [68°F to 89.6°F]), allow the machine to come to room temperature, and then turn on the power.

### RELATED LINKS

- [P. 50 Power Supply Operations](#)

## [Pump Stop Error]

This message appears when an ink cartridge is pulled out during pump operation, such as during cleaning, and is left in this state for 10 minutes or more.

Operation cannot be continued. Switch the sub power off, and then back on.

## [Emergency Stop Error]

This message appears when the emergency stop button is pressed. The sub power LED is lit in red.

### Procedure

1. Eliminate the cause of the emergency stop button being pressed.
2. Turn the emergency stop button clockwise until it stops turning, and then release the button. If the button is pulled out toward you, it is released.

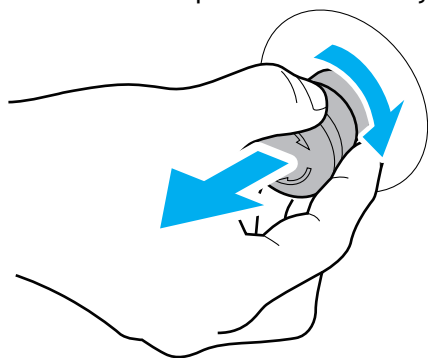

3. Hold down the sub power button for one second or longer to turn off the sub power. Repeat to turn on the sub power.  
The machine recovers from the emergency stop status.
4. Perform a nozzle drop-out test.  
Perform cleaning as necessary.

### RELATED LINKS

- [P. 64 Performing a Nozzle Drop-out Test](#)
- [P. 160 Action Taken When Dot Drop-out or Dot Displacement Occur](#)

# Appendix

# Move

---

Preparing to Move the Machine..... 238  
Procedures from Preparing to Move to Reinstallation ..... 238

# Preparing to Move the Machine

When moving the machine from its installation location, do so after performing [Ink Circulation] and securing the flat table and the print-head carriage.

## Procedures from Preparing to Move to Reinstallation

### ⚠ CAUTION

If an object is dropped behind the flat table, search for it with all power switches turned off. Otherwise sudden movement of the machine may cause injury.

### IMPORTANT

#### Important notes on moving

- Once the preparations for moving the machine are complete, move the machine promptly and turn on the machine as soon as possible after the machine is relocated. If you leave the machine alone without turning it on, the precipitated ink will coagulate and result in problems such as the clogging of the print heads.
- When moving the machine, keep it at a temperature between 5 to 40°C (41 to 104°F) and at relative humidity between 20 to 80% (with no condensation). Failure to do so may result in malfunction.
- Handle the machine with care when moving it, keeping it level (not tilted at an angle) and preventing it from striking other objects.
- When transporting in a vehicle, avoid placing machine on a tilted surface, such as on a seat, and keep the machine in a level state.

## Procedure

1. On the Utility home screen, click .
2. Click [Execute] under [Maintenance]>[Ink Circulation].  
This operation circulates the ink. This procedure will take several minutes.
3. Follow the procedure below to move the flat table to its lowest position.  
Lower the flat table using the rotary axis unit's attachment/removal menu. If the rotary axis unit is installed, remove it.  
[P. 131 Removing/Attaching Optional Items \(OA-RA-8\)](#)
  - (1) Click [Execute] under [Preferences]>[Rotary Unit Attachment/Removal].  
The flat table moves around the center position in the vertical direction.
  - (2) Open the front cover.
  - (3) When the [Attach or remove the rotary axis unit.] window appears, click [Next].
  - (4) When [Close all the covers.] is displayed, close the front cover, and then click [Finish].  
The flat table moves to its lowest position.
4. Turn off the sub power, and then turn off the main power.
5. Open the front cover, and then remove the maintenance cover.
6. Remove the retainer (A) for the print-head carriage and the retainer (B) for the flat table.  
Remove the retainers using the included hexagonal wrench.

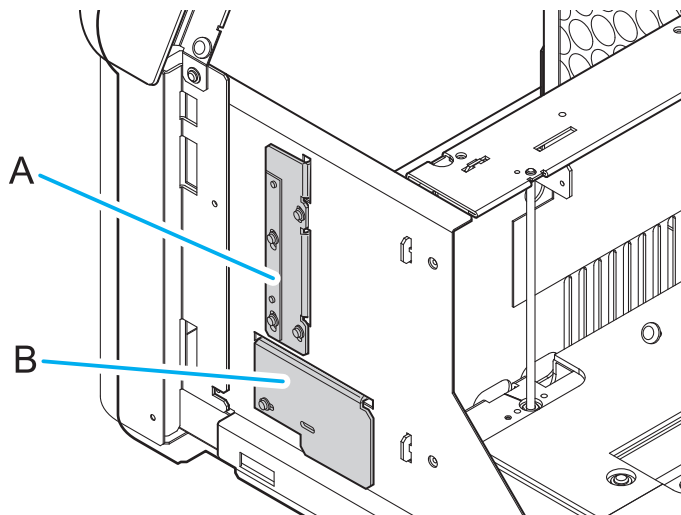

7. Push the flat table and then move it until it comes into contact with the back.

**IMPORTANT**

Move the flat table slowly.

8. Secure the print-head carriage and flat table with their retainers.

- Print-head carriage

**MEMO**

Work carefully so that you do not drop the bolts.

If a bolt falls under the flat table, pick up the bolt according to the following guidelines.

1. Move the flat table back and forth by hand to look for the bolt.

If you cannot find the bolt, perform the following operation to search the underside of the flat table.

2. Move the flat table up as instructed in the guidelines for setting up thin media, such as nozzle drop-out test paper.

a. Place the bolt on the long side of the hexagonal wrench.

Use the bolt that was used to attach this retainer.

b. Place the retainer in the position shown in the figure.

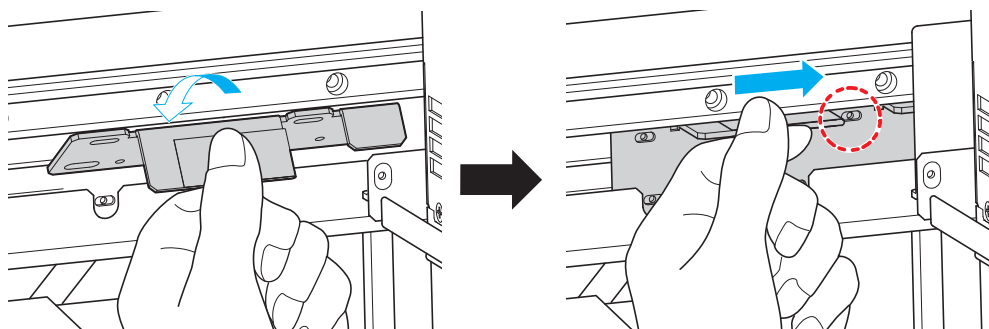

c. Using the hexagonal wrench with the bolt attached, temporarily tighten the upper right of the retainer.



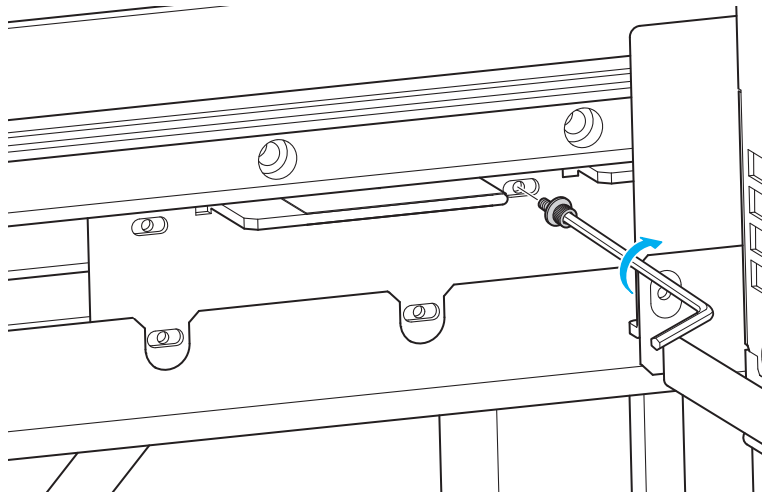

- d. Temporarily tighten the remaining three locations.
- e. Push the retainer to the right, and then fully tighten the bolts.

**IMPORTANT**

Tighten the bottom two locations lightly. Overtightening may result in bending of the mounting fixture.

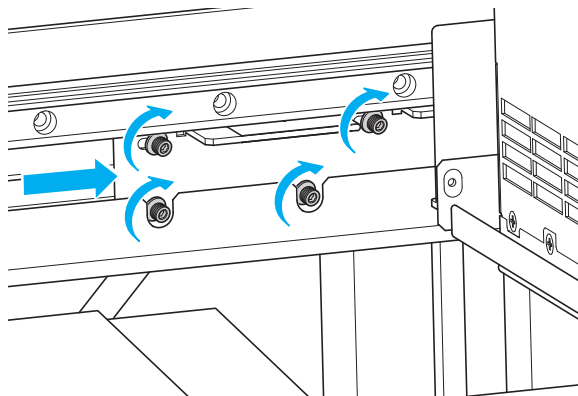

• **Flat table**

- a. Place the retainer for the flat table in the position shown in the figure. Place the retainer so that the protrusion (A) fits into the hole.

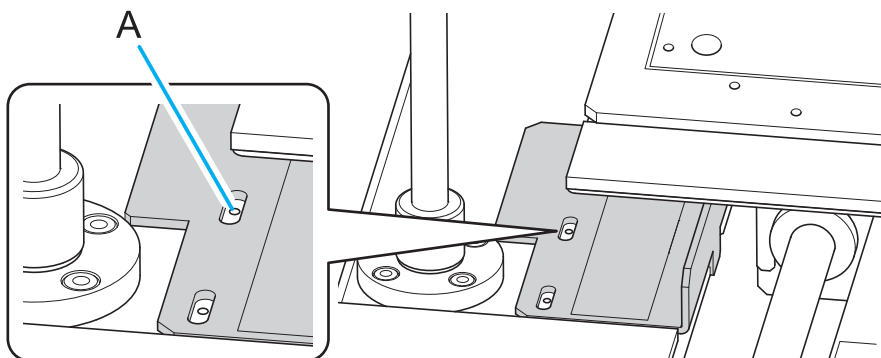

- b. Tighten the screws while pushing the retainer to the back. Use the screws that were used to attach this retainer.

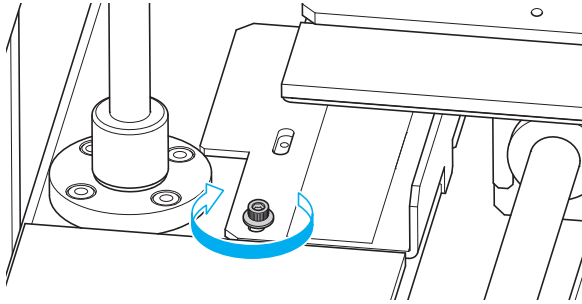

9. Attach the maintenance cover, and then close the front cover.
  - Push the maintenance cover until the magnets adhere.
  - Secure the front cover with masking tape or similar material to prevent it from opening during transport.

10. Unplug the power cable and the Ethernet connector.

11. Move the machine as soon as possible.

12. After moving the machine, immediately install it.

13. Remove the print-head carriage and the flat table retainer.
  - (1) Open the front cover, and then remove the maintenance cover.
  - (2) Remove the retainer for the print-head carriage and the retainer for the flat table. Remove them in the reverse order of step 8.
  - (3) Install the removed retainers (x 2) in the positions shown in the figure.

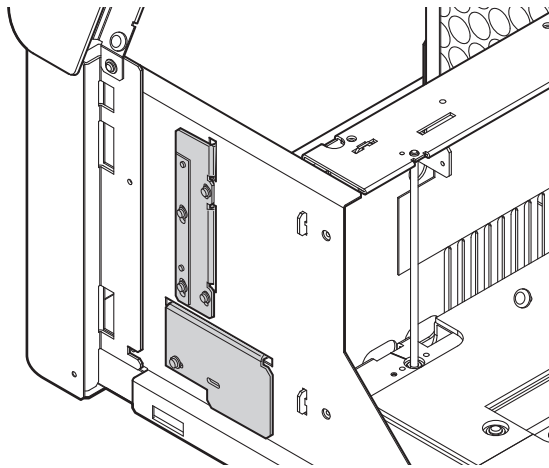

- (4) Attach the maintenance cover, and then close the front cover.

14. Turn on the main power, and then turn on the sub power. This completes the move operation.

# Main Specifications

---

- Dimensional Drawings..... 243
  - Outer Dimensions ..... 243
  - Flat Table Dimensions ..... 244
- Specifications ..... 245

# Dimensional Drawings

## Outer Dimensions

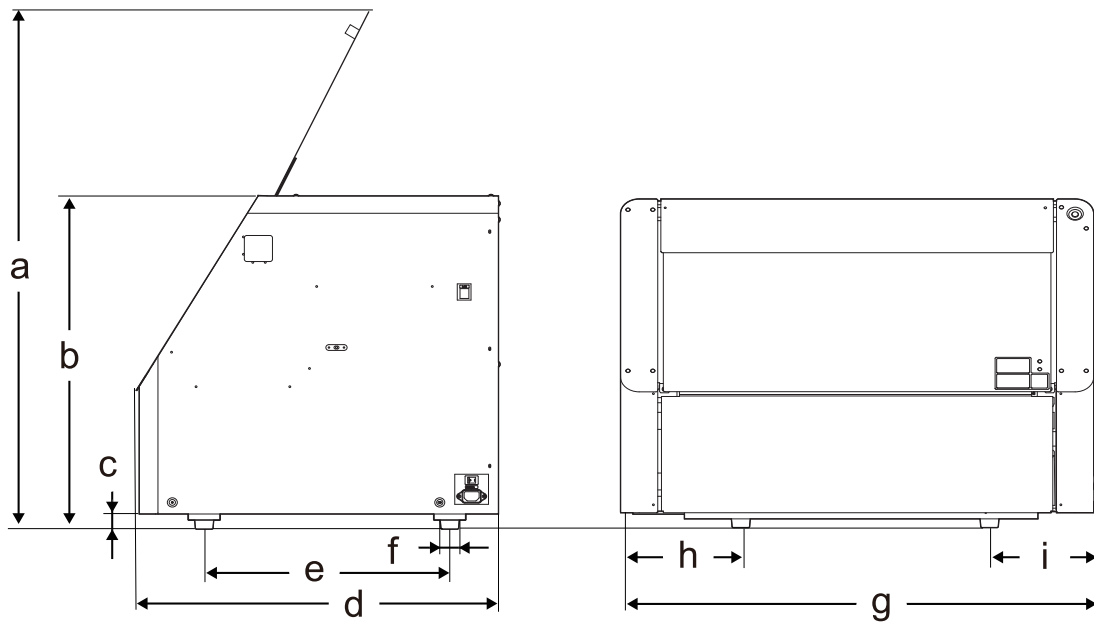

a	911 mm (35.87 in.)	d	586 mm (23.07 in.)	g	768 mm (30.24 in.)
b	580 mm (22.83 in.)	e	393 mm (15.47 in.)	h	194 mm (7.64 in.)
c	26.2 mm (1.03 in.)	f	32 mm (1.26 in.)	i	173 mm (6.81 in.)

**Flat Table Dimensions**

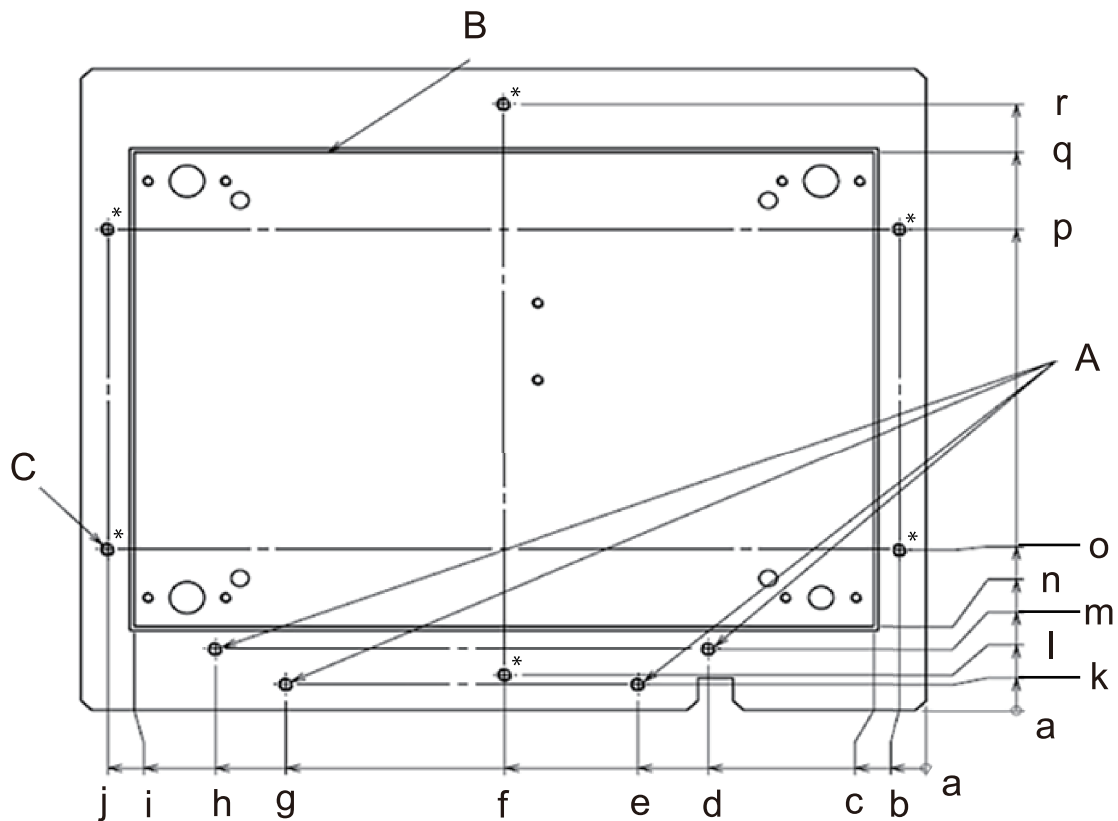

A: M4 holes for fixing rotary axis unit (OA-RA-8) When the rotary axis unit is not in use, they can be used for securing a jig.					
B: Do not use holes within the white line.					
C: M4 holes (six locations marked with *) They can be used for securing a jig.					
a	0 mm (0 in.)	g	182 mm (7.17 in.)	m	19 mm (0.75 in.)
b	7.5 mm (0.30 in.)	h	202 mm (7.95 in.)	n	26 mm (1.02 in.)
c	15 mm (0.59 in.)	i	225 mm (8.86 in.)	o	50 mm (1.97 in.)
d	62 mm (2.44 in.)	j	232.5 mm (9.15 mil)	p	150 mm (5.9 in.)
e	82 mm (3.23 in.)	k	8 mm (0.31 in.)	q	174 mm (6.85 in.)
f	120 mm (4.72 in.)	l	11 mm (0.43 in.)	r	189 mm (7.44 in.)

# Specifications

Printing method		Piezo ink-jet method
Attachable objects to be printed on	Width	Max. 240 mm (9.4 in.)
	Length	Max. 178 mm (7 in.)
	Thickness	Max. 102 mm (4 in.)
	Weight	Max. 3 kg (6.6 lb.)
Maximum printing width/printing length		Max. 210 × 148 mm (8.2 in. × 5.8 in.)
Ink	Type	ECO-UV (EUUV5) 220 ml cartridge
	Color	Five colors (cyan, magenta, yellow, black, and white) and primer
Ink-curing unit		Built-in UV-LED lamp
Printing resolution (dots per inch)		Max. 1,440 dpi
Connectivity		Ethernet (100BASE-TX/1000BASE-T, automatic switching)
Power-saving function		Automatic sleep feature
Rated input		100 - 240 Va.c. 50/60 Hz 1.1 A
Power consumption	During operation	Approx. 90 W
	Sleep mode	Approx. 30 W
Acoustic noise level	During operation	59 dB (A) or less
	During standby	52 dB (A) or less
Dimensions (Width × Depth × Height)		768 mm × 586 mm × 580 mm (30.3 in. × 23.1 in. × 22.9 in.)
Weight		61 kg (134.5 lb.)
Environment	During operation*1	Temperature: 20 to 32 °C (68 to 89.6 °F) (22 °C [71.6 °F] or higher recommended) Humidity: 35%RH to 80%RH (no condensation)
	Not operating	Temperature: 5 °C to 40 °C (41 °F to 104 °F) Humidity: 20%RH to 80%RH (no condensation)
Included items		Power cord, cleaning liquid, User's Manual, software (FlexiDESIGNER VersaSTUDIO Edition, VersaWorks, Roland DG Connect), etc.

\*1 Operating environment

(1): Use in an operating environment within this range.

